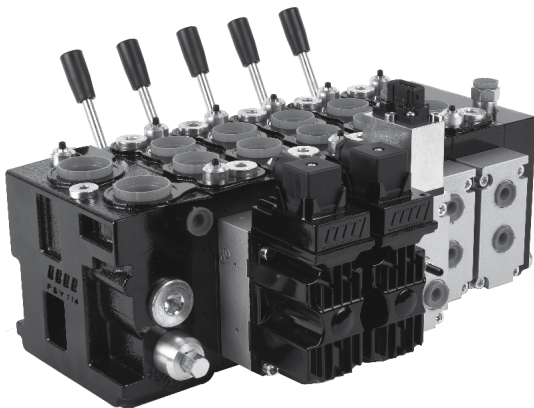

General description	142.
PDI open centre inlet section function	146.
PDI closed centre inlet section function	150.
PDI inlet sections code numbers	155.
PIU solenoid LS unloading valves	159.
PDW working sections code numbers	161.
PDE end sections code numbers	165.
PDS flow control spool	170.
PDR spool centered set	172.
PDS pressure control spool	177.
Modules and code numbers	179.
Shock and suction valves	184.
PDL Electrical LS _{A/B} unloading	186.
PDL Proportional Electrical LS _{A/B} unloading	190.
PEAC121 Proportional closed loop spool control input signal 0,5 U _{dc}	191.
PEAC122 Proportional closed loop spool control input signal control 0 ÷ 10 V	199.
PEAC126 Proportional closed loop spool control input signal control 4 ÷ 20 mA	207.
PEAC021 Proportional open loop spool control input signal 0,5 U _{dc}	215.
PEAC022 Proportional open loop spool control input signal 0 ÷ 10 V	222.
PEAC026 Proportional open loop spool control input signal 4 ÷ 20 mA	229.
PEAD2 Proportional open loop spool control input signal PWM and ON-OFF	236.
PEAP2 Proportional open loop spool control input signal PWM and ON-OFF	242.
Overall dimension drawing	248.
Product selection chart	282.
Composition form	294.

PDV114 is a hydraulic proportional directional valve, designed to offer a wide range of control options and flexibility.

The **PDV114** modular system enables bankable groups to perform many individual tasks, to meet and exceed the changing control needs of the off-highway machines of today, and well into the future to maximize the efficiency, controllability and reliability of vehicles.

**PDV114 main features:**

- Load sensing up-stream pressure compensation
- High flow/low pressure drop capability in a compact size
- Integrated pump unloading system
- Integrated cut-off pump system
- Open/closed centre shifting system
- Precise metering capabilities
- LSA-LSB electrical unloading
- LSA-LSB electrical working pressure remote control
- Constant flow regardless of pressure
- Working sections symmetrical flow
- Optional priority inlet for steering or different priority functions
- Optional dual hydraulic pilot and electrohydraulic control
- ATEX and IECEx configuration
- CAN-Bus communication
- EMC immunity ensures high safety with regard to electro-magnetic compatibility

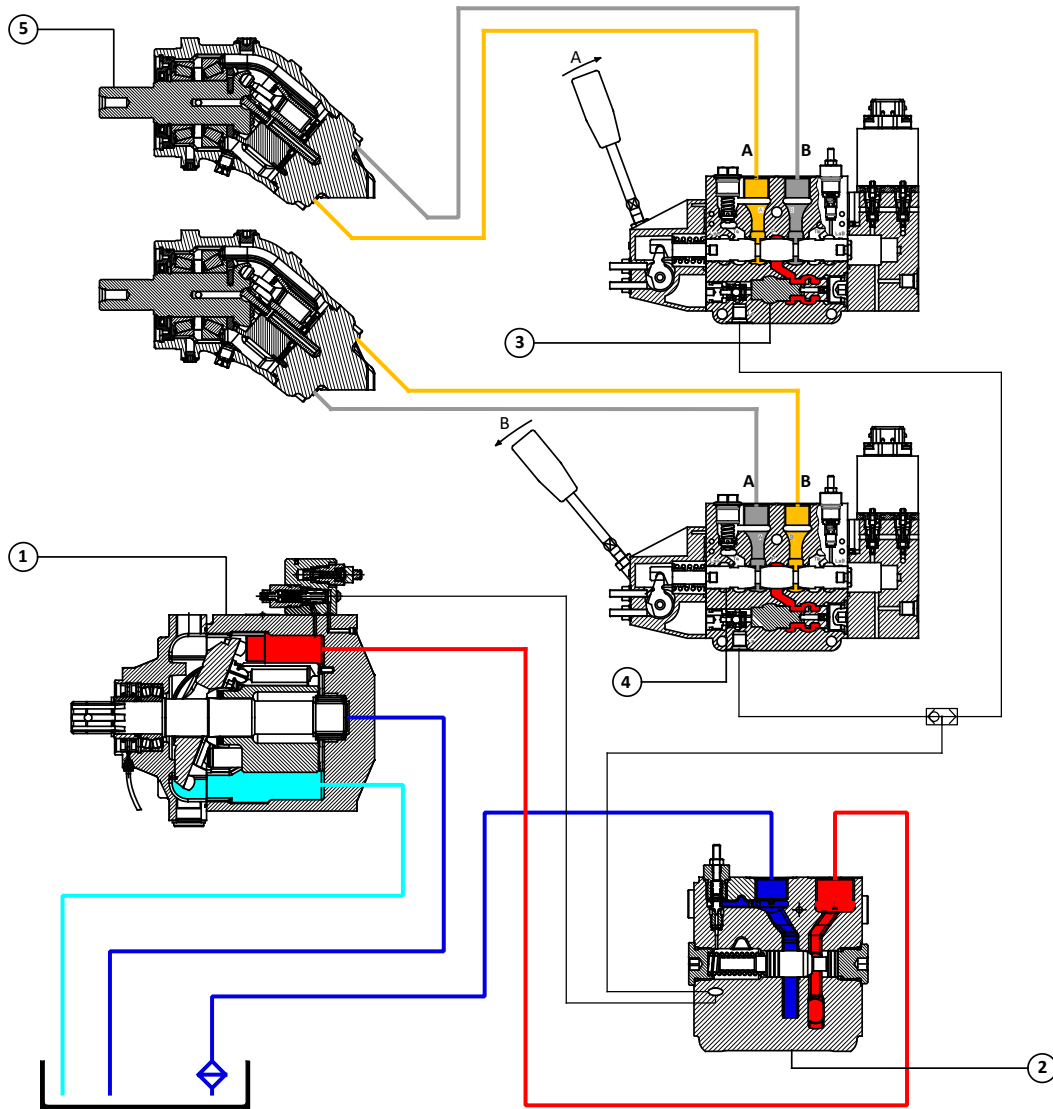

High pressure port of **PPV** piston pump ① supply the closed centre inlet section of **PDV114** proportional valve ② which in turn feeds the down-stream working sections.

The **PDS** spool neutral position ④ unload the LS pump signal to tank, so that the swashplate angle is towards the minimum displacement and pressure in stand-by setting.

The spool position determines the flow demands (speed rotation) of the two **HPM** motors ⑤.

The PDS main spool compares the pressure drop before and after the spool notches (differential pressure Δp), and therefore, the pump flow remain constant.

If the differential pressure increase, the pump swashplate is swivelled back towards the minimum displacement, and if the differential pressure decrease, the swashplate angle increase towards the max flow displacement until balance is restored within the valve.

Actuators load determines the working pressure, and the built-in pressure compensator ③ enable simultaneously function regardless of different working pressure.

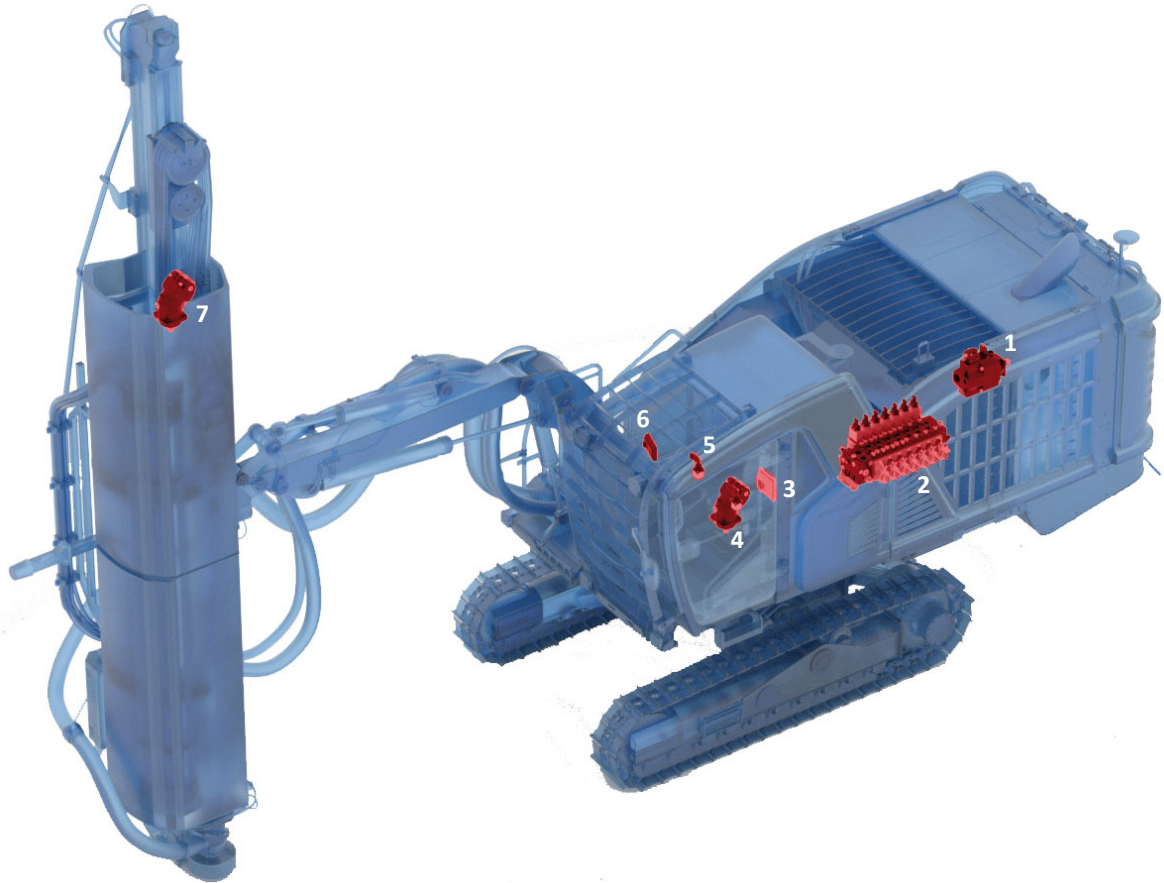

- 1. PPV110 load sensing piston pump
- 2. PDV114/7 closed centre inlet
- 3. I/O controller PHSI7101008
- 4. PPM80 bent axis piston motor
- 5. Electronic double axis joystick PEJD
- 6. Graphic display PDHI703000
- 7. PPM20 bent axis piston motor

The hydraulic features listed in this chart, are typical measured data obtained by using mineral based hydraulic oil according to DIN 51524 with a viscosity of 21 mm²/sec [102 SUS] and a temperature of 50 °C [122 °F]

Oil flow rate	PDI inlet section, P port		260 l/min (max)	69 US gal/min
	PDIM - Mid inlet section, P port		380 l/min	100 US gal/min
	A, B port with pressure compensator		190 l/min	50 US gal/min
	A, B port without pressure compensator		205 l/min	54 US gal/min
Max. pressure	P port	Pressure relief valve setting	400 bar	5800 psi
		Working pressure	370 bar	5370 psi
	A, B port		370 bar	5370 psi
	Ty port, directly to tank			
	T port	Static	25 bar	363 psi
		Dynamic	37 bar	537 psi
Max. pilot pressure oil supply			18 ÷ 22 bar	260 ÷ 320 psi
Oil temperature	Recommended		30 ÷ 65 °C	86 °F ÷ 149 °F
	Min		-30 °C	-22 °F
	Max		90 °C	194 °F
Ambient temperature			-30 ÷ 60 °C	-22 ÷ 140 °F
Oil viscosity	Operating range		12 ÷ 75 mm ² /sec	65 ÷ 347 SUS
	Min		4 mm ² /sec	39 SUS
	Max		460 mm ² /sec	2128 SUS
Spool stroke	Standard		8 mm	0,31 in
	Flow control proportional range		6,5 mm	0,26 in
	Pressure control proportional range		7 mm	0,28 in
Dead band spool	Flow control		1,5 mm	0,06 in
	Pressure control		1 mm	0,04 in
Max internal leakage A/B port at 100 bar [1450 psi] and 21 mm ² /sec		A/B T without shock valves	21 cm ³ /min	1,28 in ³ /min
		A/B T with shock valves	25 cm ³ /min	1,53 in ³ /min
Filtration	Max. contamination: class 9 according to NAS 1638 (20/18/15 according to ISO 4406)			

PDH module - hydraulic control

Pilot pressure	Spool start movement	4 bar / 58 psi
	Spool end stroke	15 bar / 218 psi
Max. pilot pressure		30 bar / 436 psi

PDV74 internal filters, mesh 100 µm

Mineral oil hydraulic fluid: according to DIN 51524 and 51525 or ISO 6743/4 PDV74 can also be used with phosphate esters (HFDR), water-glycol (HFC) or water oil (HFB) mixes, subject to our Technical Dept. approval

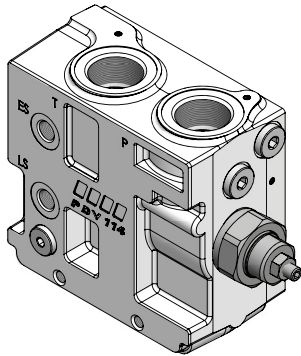

Hydraulic diagram

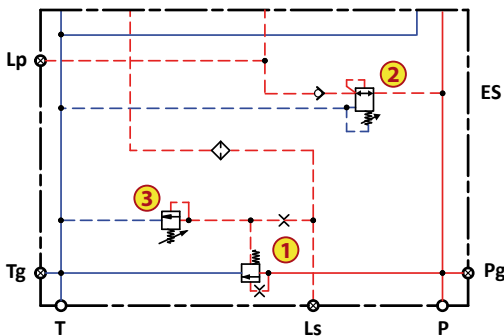

Designed for use with fixed displacement pumps.

Inlet comes standard with pressure compensated 3-way flow regulator ①, that when pump is started and working sections spools are in neutral position, it's unloaded to tank, and the oil flow being supplied from the pump, passes through the 3-way flow regulator to tank with minimal off-load pressure drop (see diagram below).

When one or more of the spools are actuated, the highest working pressure signal is fed to the 3-way flow regulator, that maintains the Δp at a constant level, so that the flow rate is independent of the load, and proportional to the opened spool area. The built in pressure reducing valve ②, act as the pilot pressure supply for the electrical actuators, as well as, the hydraulic remote controls.

When the main PDS spools are actuated, the exceeding pump flow is being sent to tank at the highest load pressure value. If the working pressure reaches the setting of the upstream max pressure pilot relief valve ③, the 3-way flow regulator will be opened to tank, thus limiting the working pressure inside the complete PDV.

On this configuration, the level of safety degrees for the complete PDV valve is really low, therefore, operator's great supervision is strictly request.

Neutral flow-pressure drop in PDI, open centre

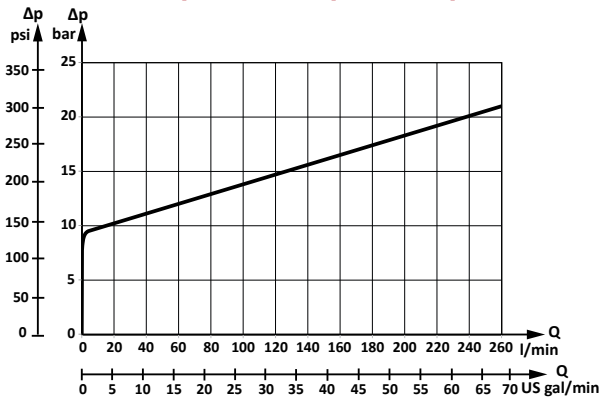

Pressure relief valve characteristic in PDI, open centre

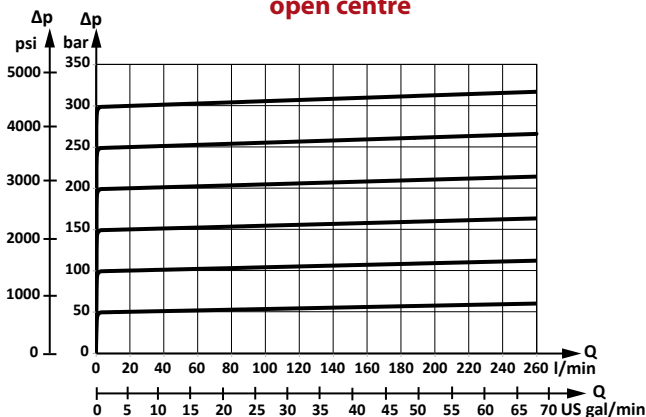

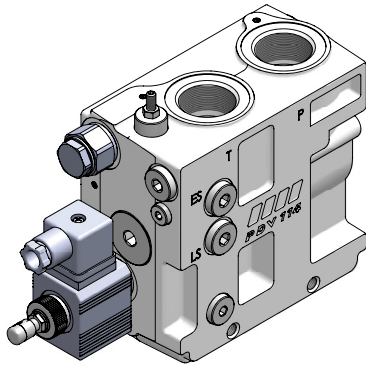

Hydraulic diagram

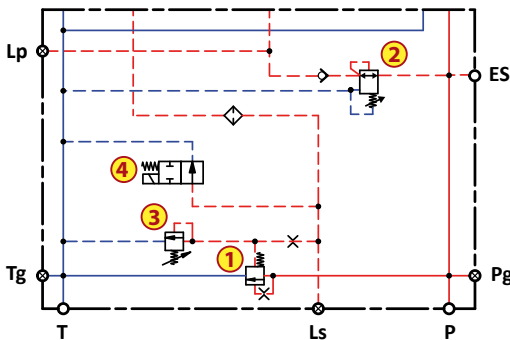

Designed for use with fixed displacement pumps.

Inlet comes standard with pressure compensated 3-way flow regulator ①, that when pump is started and working sections spools are in neutral position, it's unloaded to tank, and the oil flow being supplied from the pump, passes through the 3-way flow regulator to tank with minimal off-load pressure drop (see diagram below).

When one or more of the spools are actuated, the highest working pressure signal is fed to the 3-way flow regulator, that maintains the Δp at a constant level, so that the flow rate is independent of the load, and proportional to the opened spool area. The built in pressure reducing valve ②, act as the pilot pressure supply for the electrical actuators, as well as, the hydraulic remote controls.

When the main PDS spools are actuated, the exceeding pump flow is being sent to tank at the highest load pressure value. If the working pressure reaches the setting of the upstream max pressure pilot relief valve ③, the 3-way flow regulator will be opened to tank, thus limiting the working pressure inside the complete PDV.

According to an electrical signal coming from the remote controls or I/O controller, the PDU solenoid unloading valve ④, enable the LS signal to be relieved to tank, and the effect of this configuration is an almost pressureless system, where the activated actuators will be automatically catted off. The pressure in the system will be reduced to the sum of the tank port pressure, plus the neutral flow pressure drop through the 3-way flow regulator.

Care must be given, because all the actuators whose working pressure is lower than the pressure drop through the 3-way regulator, might be still operated.

Also with the use of PDU emergency solenoid unloading valve, the level of safety degrees for the complete PDV valve is quite low, therefore, operator's supervision is required.

Neutral flow-pressure drop in PDI, open centre

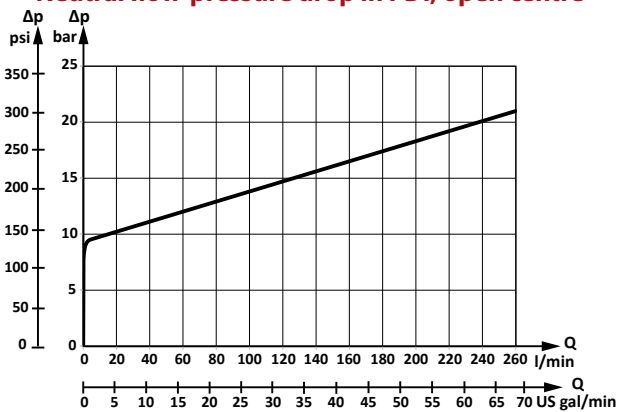

Pressure relief valve characteristic in PDI, open centre

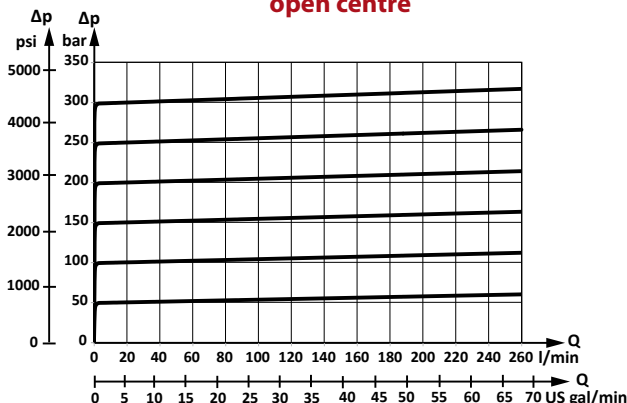

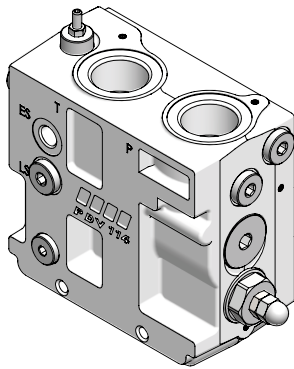

Hydraulic diagram

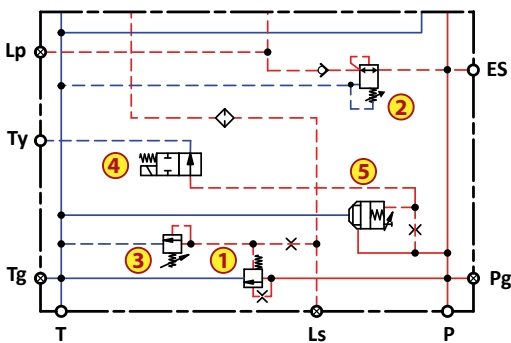

Designed for use with fixed displacement pumps.

Inlet comes standard with pressure compensated 3-way flow regulator ①, that when pump is started and working sections spools are in neutral position, it's unloaded to tank, and the oil flow being supplied from the pump, passes through the 3-way flow regulator to tank with minimal off-load pressure drop (see diagram below).

When one or more of the spools are actuated, the highest working pressure signal is fed to the 3-way flow regulator, that maintains the Δp at a constant level, so that the flow rate is independent of the load, and proportional to the opened spool area. The built in pressure reducing valve ②, act as the pilot pressure supply for the electrical actuators, as well as, the hydraulic remote controls.

When the main PDS spools are actuated, the exceeding pump flow is being sent to tank at the highest load pressure value. If the working pressure reaches the setting of the upstream max pressure pilot relief valve ③, the 3-way flow regulator will be opened to tank, thus limiting the working pressure inside the complete PDV.

By means of an electrical signal coming from the remote controls or I/O controller, the PDU solenoid valve ④, operates the poppet type pilot operated valve ⑤, which in turn, allows the full flow coming from the pump to be relieved to tank, bypassing the 3-way flow regulator ①.

The effect of this condition is a complete and safely pressureless system, where all actuators will be automatically catted-off, and the pressure into the system will be reduced to the sum of the tank port pressure, plus the pressure drop through the poppet unloading valve (see characteristic curve below)

When the inlet section comes with this configuration and the pump unloading system is connected with the active fault monitoring spool actuators, the level of safety degree protection for the complete hydraulic system becomes very high, operator free, and helps OEM to meet the PL (Performance Level) required to be comply with the safety demands of Machinery Directive 2006/42/EC.

Neutral flow-pressure drop in PDI, open centre

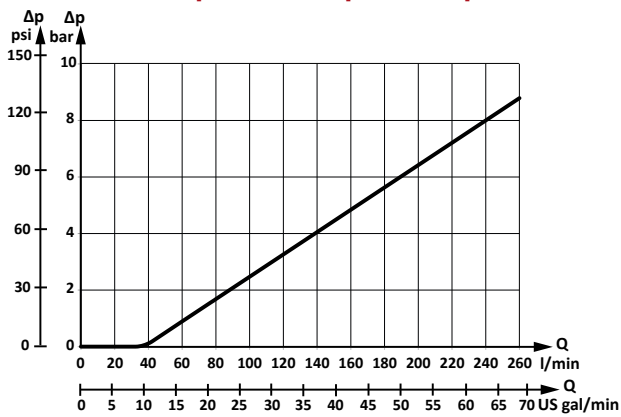

Pressure relief valve characteristic in PDI, open centre

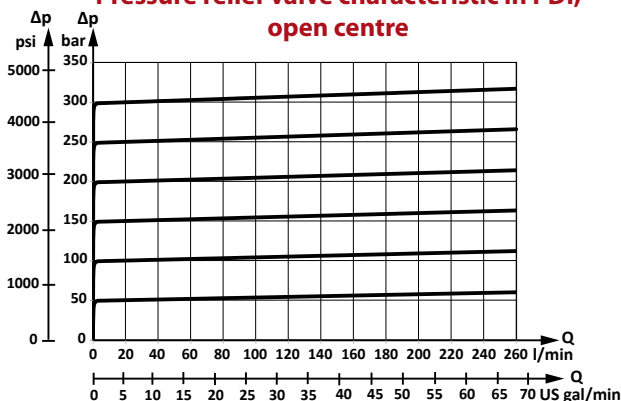

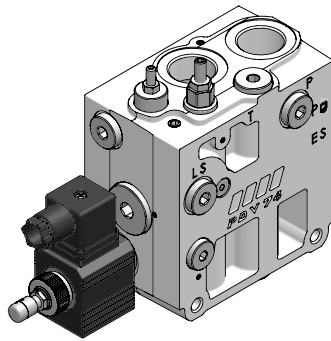

Hydraulic diagram

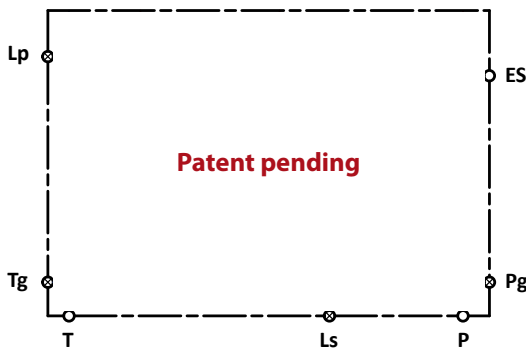

Neutral flow-pressure drop in PDI, open centre

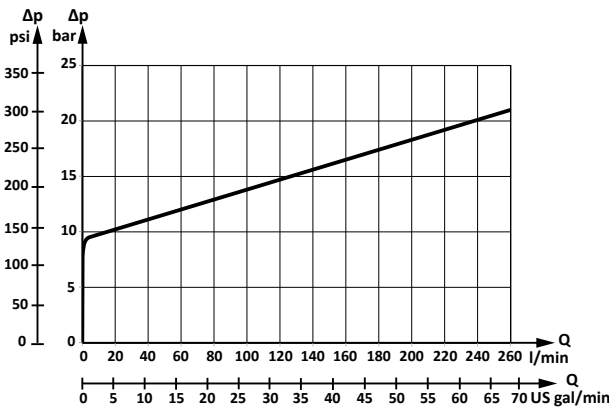

Pressure relief valve characteristic in PDI, open centre

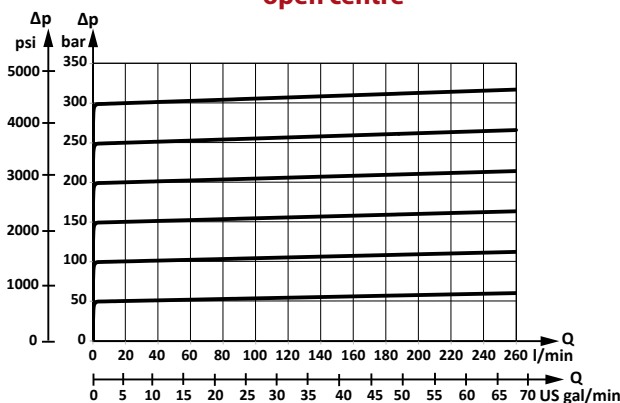

Designed to be configured either as open centre (fixed displacement pumps) or closed centre version (variable displacement pumps.)

Inlet comes standard with pressure compensated 3-way flow regulator ①, that when pump is started and working sections spools are in neutral position, it's unloaded to tank, and the oil flow being supplied from the pump, passes through the 3-way flow regulator to tank with minimal off-load pressure drop (see diagram below).

When one or more of the spools are actuated, the highest working pressure signal is fed to the 3-way flow regulator, that maintains the Δp at a constant level, so that the flow rate is independent of the load, and proportional to the opened spool area. The built in pressure reducing valve ②, act as the pilot pressure supply for the electrical actuators, as well as, the hydraulic remote controls.

When the main PDS spools are actuated, the exceeding pump flow is being sent to tank at the highest load pressure value. If the working pressure reaches the setting of the upstream max pressure pilot relief valve ③, the 3-way flow regulator will be opened to tank, thus limiting the working pressure inside the complete PDV.

By acting clockwise on the pilot shifting spool ④, without changing any components, the inlet section circuit will be transformed into closed centre configuration.

In this configuration the load sensing pilot pressure is led to pump control via the LS connection. When a main spool is actuated, the pump regulator will adjust the displacement so that the set differential pressure (stand-by pressure) between P and LS signal is maintained.

The pressure relief valve 3 is to be set at 35 bar above maximum cut-off pressure set on the pump.

The LS control performs as a constant pressure control also, decreasing pump displacement when system pressure reaches the PC setting.

The pressure compensating function has the priority over the load sensing function.

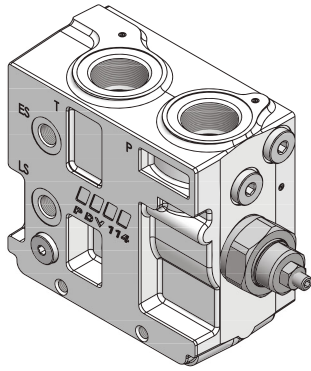

Designed for use with LS variable displacement pumps.

Inlet comes standard without pressure compensated 3-way flow regulator.

When pump is started and PDV spools are in neutral position, the LS pump signal is unloaded to tank.
When one or more of the spools are actuated, the highest signal is sent to the pump regulator that control the pump swashplate angle. The PDS main spool compares the pressure drop before and after the spool notches (differential pressure Δp), and therefore, the pump flow remain constant.

The position of the PDS spool determines the flow demand. If the differential pressure increase, the pump swashplate is swivelled back towards the minimum displacement, and if the differential pressure decrease, the swashplate angle increase towards the max flow displacement until balance is restored within the valve.

The inlet section can comes with an optional pressure relief valve ① that should be set at pressure about 35 bar above maximum system pressure set on the pump regulator.

According to an electrical signal coming from the remote controls or I/O controller, the PIU solenoid unloading valve ② enable the LS signal to be relieved to tank.

The effect of this configuration is an almost pressureless system, where the activated actuators will be automatically catted off, and the pressure in the system will be reduced to the sum of the tank port pressure, plus the differential pressure of the pump, therefore, care must be given, because all the actuators whose working pressure is lower than the remaining pressure might be still operated. The built in pressure reducing valve ③, act as the pilot pressure supply for the electrical actuators, as well as, the hydraulic remote controls.

Also with the use of PIU emergency solenoid unloading valve, the level of safety degrees for the complete PDV valve is quite low, therefore, operator's great supervision is required.

Hydraulic diagram

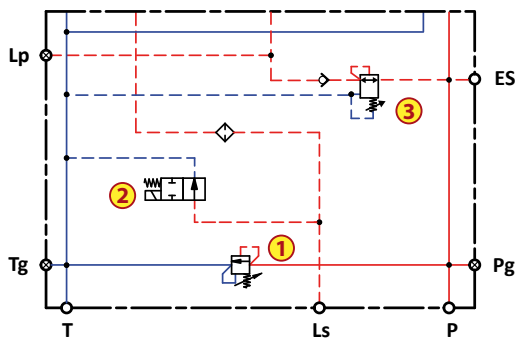

Pressure relief valve characteristic in PDI, open centre

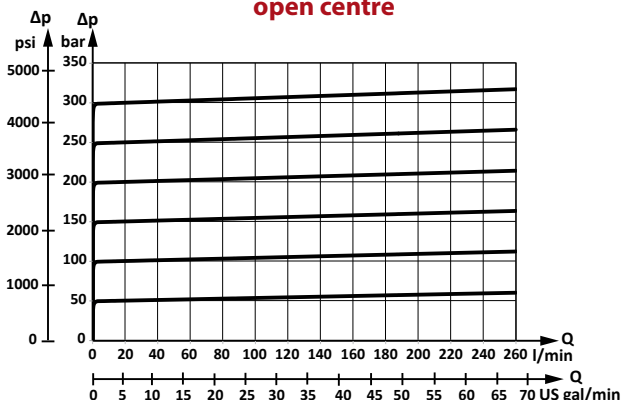

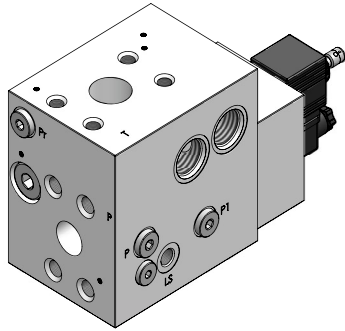

Hydraulic diagram

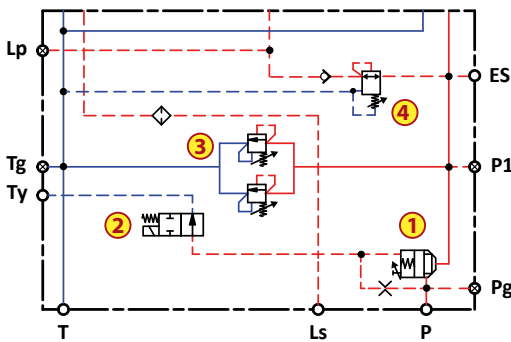

Pressure drop cut-off system in PDI, closed centre

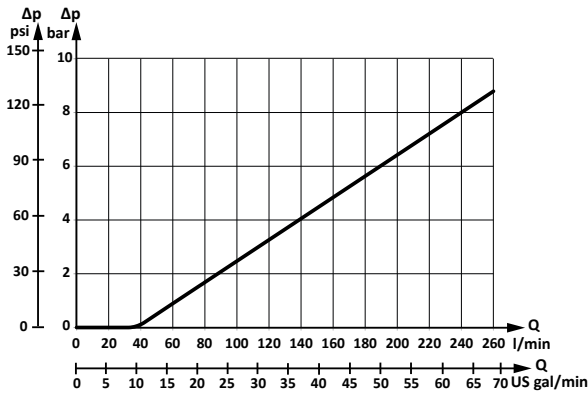

Pressure relief valve characteristic in PDI, closed centre

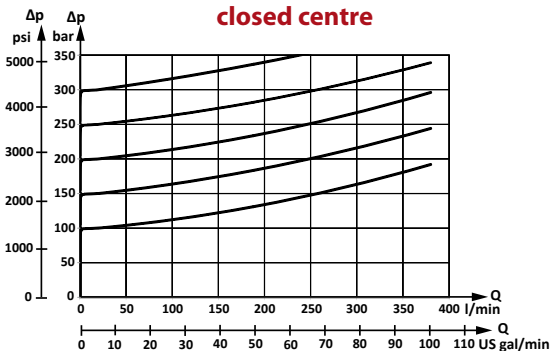

Designed for use with LS variable displacement pumps.

This version of inlet comes standard with a double stage cut-off pump system (1), that when activated according to an electrical signal (2), all down-stream working section will be perfectly and safely sealed from pressure and flow, protecting the complete hydraulic machines control against the negative effect of the remaining stand by pressure.

Inlet comes standard without pressure compensated 3-way flow regulator.

When pump is started and PDV spools are in neutral position, the LS pump signal is unloaded to tank.

When one or more of the spools are actuated, the highest signal is sent to the pump regulator that control the pump swashplate angle.

The PDS main spool compares the pressure drop before and after the spool notches (differential pressure Δp), and therefore, the pump flow remain constant.

The position of the PDS spool determines the flow demand. If the differential pressure increase, the pump swashplate is swivelled back towards the minimum displacement, and if the differential pressure decrease, the swashplate angle increase towards the max flow displacement until balance is restored within the valve.

The inlet section can comes with an optional pressure relief valve (3) that should be set at pressure about 35 bar above maximum system pressure set on the pump regulator.

The built in pressure reducing valve (4), act as the pilot pressure supply for the electrical actuators, as well as, the hydraulic remote controls.

When the inlet section comes with this configuration and the cut-off pump system is connected with the active fault monitoring spool actuators, the level of safety degree protection for the complete hydraulic system becomes very high, operator free, and helps OEM to meet the PL (Performance Level) required to be comply with the safety demands of Machinery Directive 2006/42/EC.

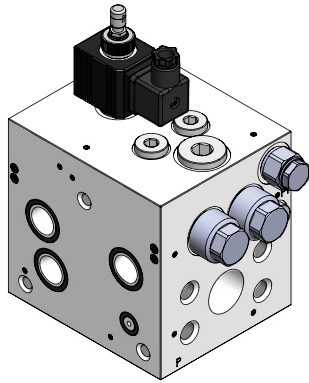

Hydraulic diagram

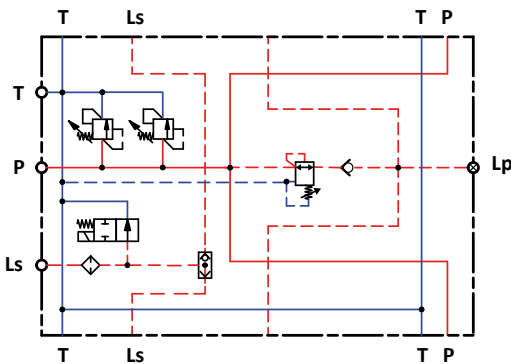

Pressure relief valve characteristic in PDI, closed centre

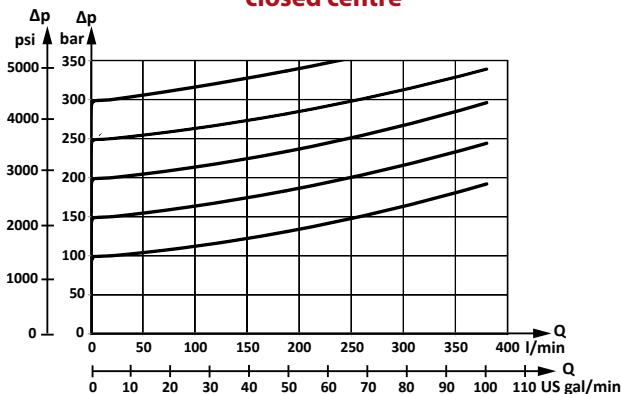

Designed for use with LS variable displacement pumps.

PDIM is a MID inlet section that allows the PDV74 to be supplied with a larger variable pump flow capacity with a lower pressure drop.

PDIM enable to PDW to be mounted on both sides of the pump side module, therefore, the PDW fitted on PMID left side, the A-B work port position are reversed.

Inlet comes standard without pressure compensated 3-way flow regulator.

When pump is started and PDV spools are in neutral position, the LS pump signal is unloaded to tank.

When one or more of the spools are actuated, the highest signal is sent to the pump regulator that control the pump swashplate angle.

The PDS main spool compares the pressure drop before and after the spool notches (differential pressure Δp), and therefore, the pump flow remain constant.

The position of the PDS spool determines the flow demand. If the differential pressure increase, the pump swashplate is swivelled back towards the minimum displacement, and if the differential pressure decrease, the swashplate angle increase towards the max flow displacement until balance is restored within the valve.

The inlet section may comes with an optional pressure relief valve that should be set at pressure about 35 bar above maximum system pressure set on the pump regulator.

According to an electrical signal coming from the remote controls or I/O controller, the PIU solenoid unloading valve enable the LS signal to be relieved to tank.

The effect of this configuration is an almost pressureless system, where the activated actuators will be automatically catted off, and the pressure in the system will be reduced to the sum of the tank port pressure, plus the differential pressure of the pump, therefore, care must be given, because all the actuators whose working pressure is lower than the remaining pressure might be still operated.

Also with the use of PIU emergency solenoid unloading valve, the level of safety degrees for the complete PDV valve is quite low, therefore, operator's great supervision is required.

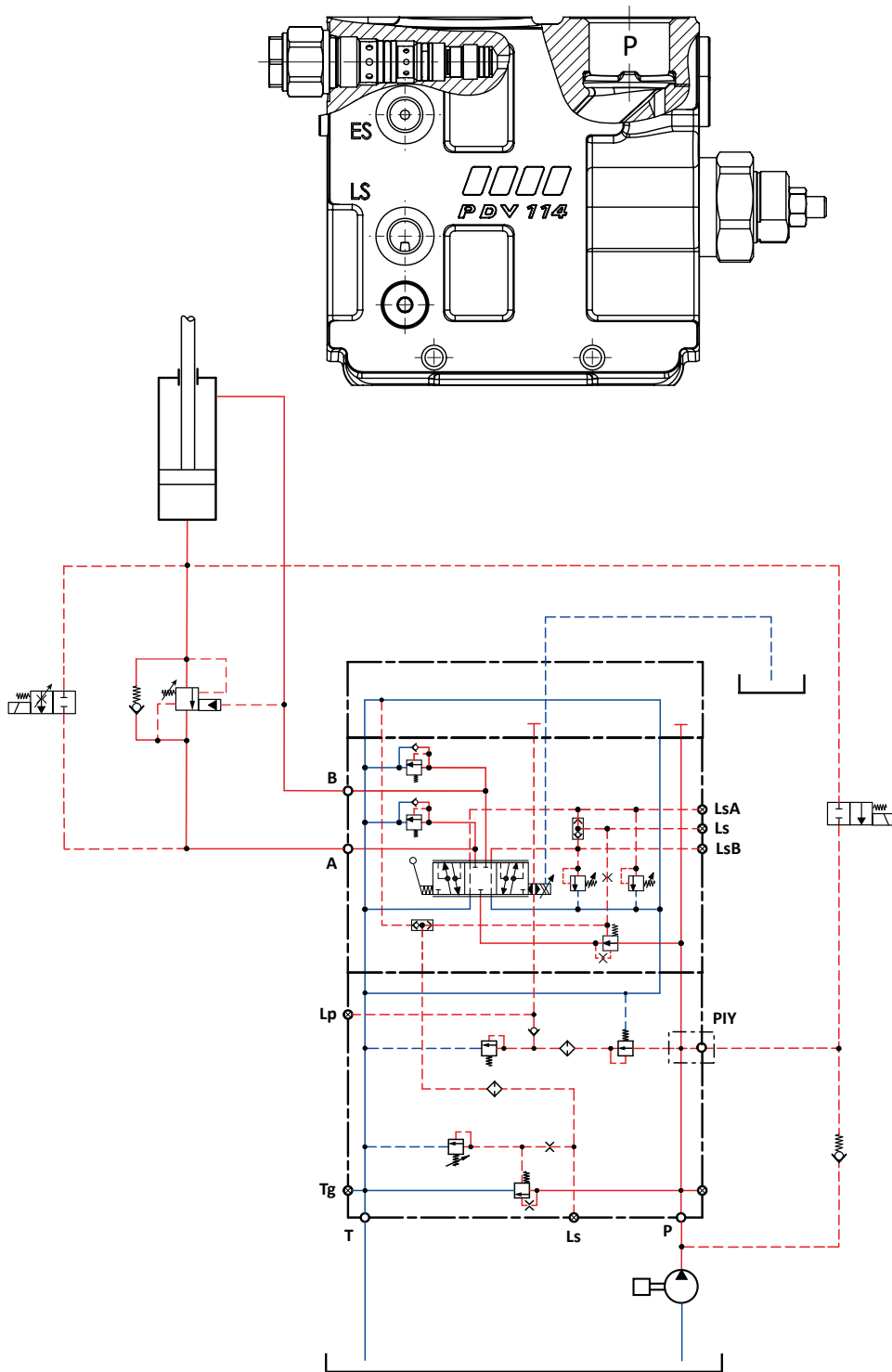

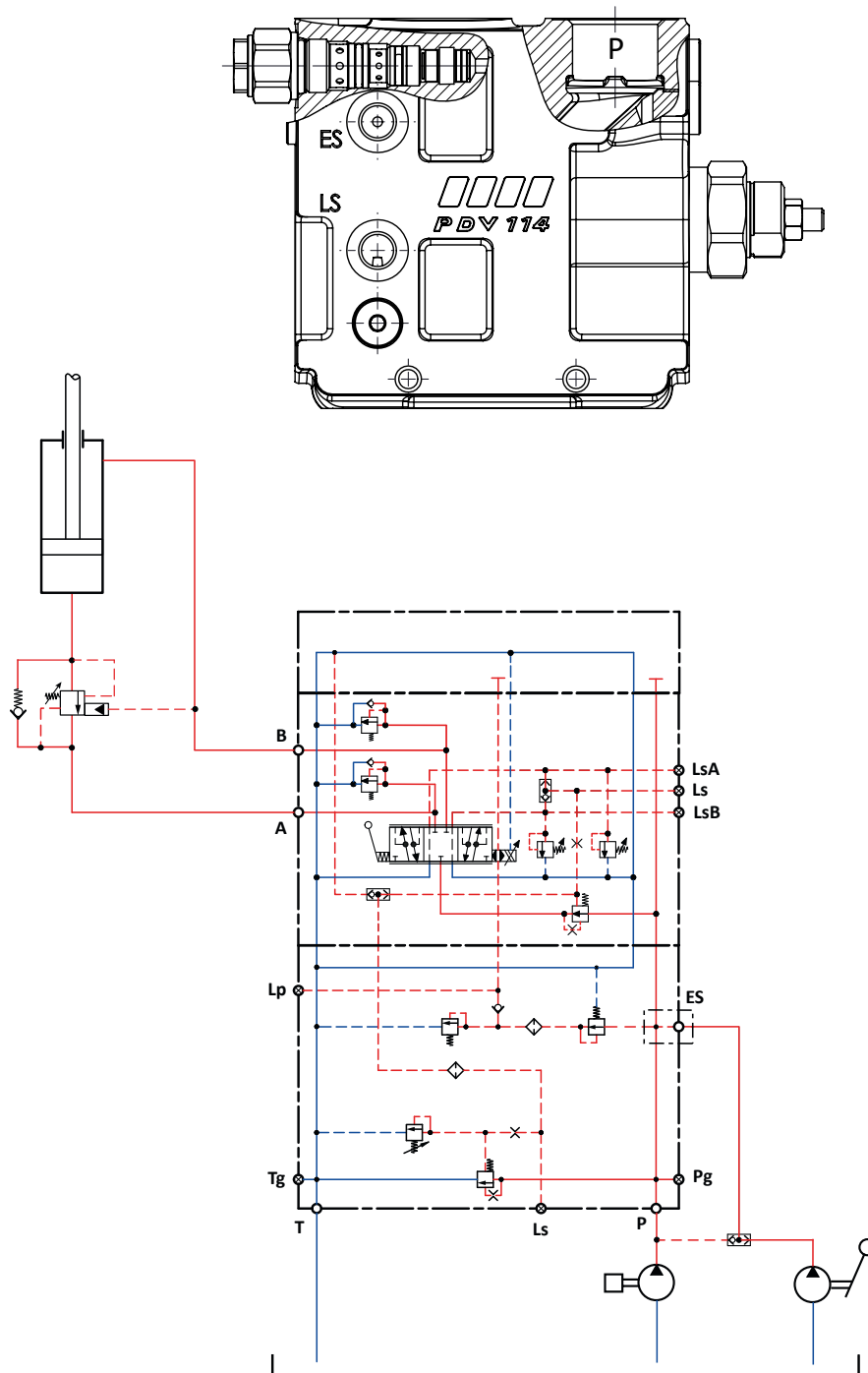

This inlet configuration (for open or closed centre) is suited to supply the PDV74 with a flow from an auxiliary manual operated emergency pump.

Normally the main pump supply the built in pressure reducing valve through the PIY, screw-in cartridge.

In case of main pump failure, the external shuttle valve ensure that the main pressure reducing valve is being supplied from the emergency hand pump, and the pilot oil supply available for electric actuators.

Product

Hydraulic diagram

Description

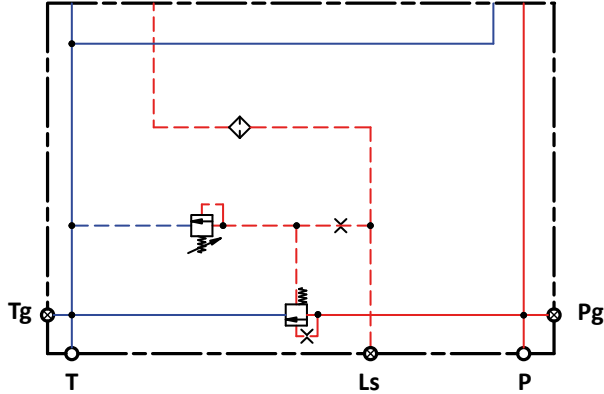
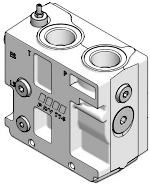

For mechanically actuated valves, only

Code numbers

PDI01A3000

PDI01A30010

BSP

UN-UNF

Connections thread see page [249](#)

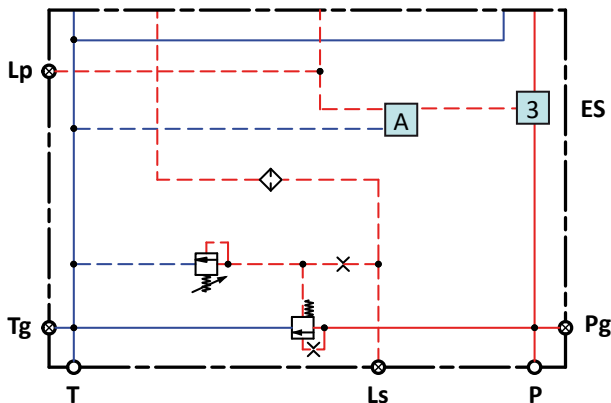
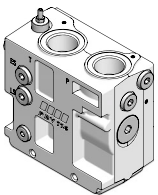

With pilot oil supply for electrically and hydraulic actuated valves **3**

Code numbers

PDI01A4000

PDI01A40010

BSP

UN-UNF

Connections thread see page [249](#)

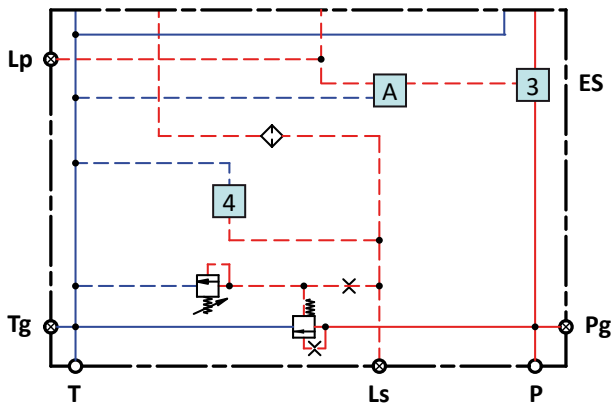
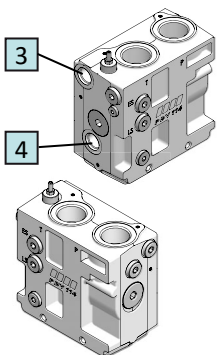

With pilot oil supply for electrically and hydraulic actuated valves **3** and facility for LS unloading **4**

Code numbers

PDI01A4100

PDI01A41010

BSP

UN-UNF

Connections thread see page [249](#)

Product

Hydraulic diagram

Description

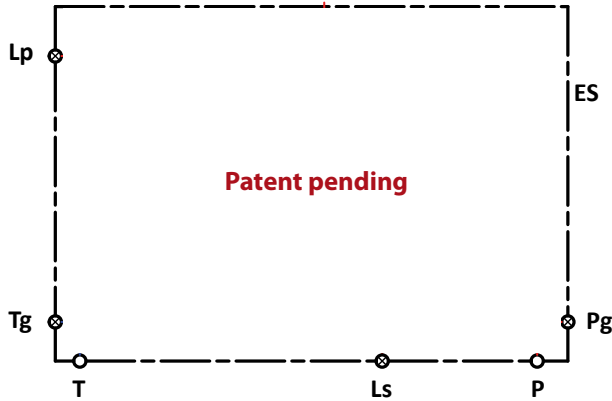

With pilot oil supply, for electrically and hydraulic actuated valves **3** and shifting pump system **5**

Code numbers	
PDI01B40000	PDI01B40010
BSP	UN-UNF
Connections thread see page 249	

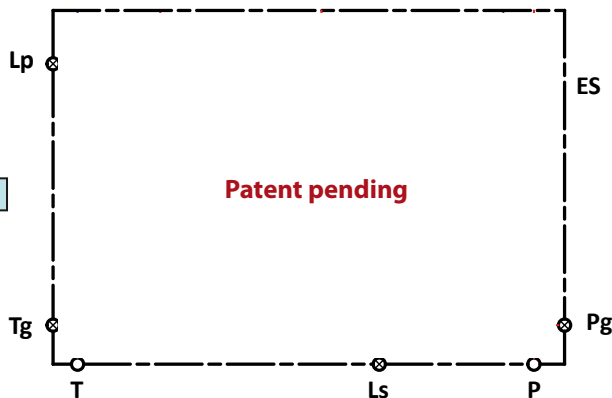
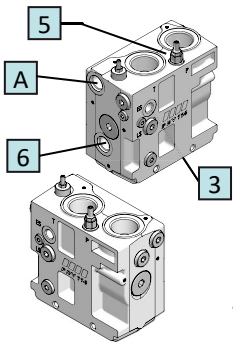

With pilot oil supply for electrically and hydraulic actuated valves **5**, shifting pump system **6** and facility for LS unloading **3**

Code numbers	
PDI01B41000	PDI01B41010
BSP	UN-UNF
Connections thread see page 249	

Product

Hydraulic diagram

Description

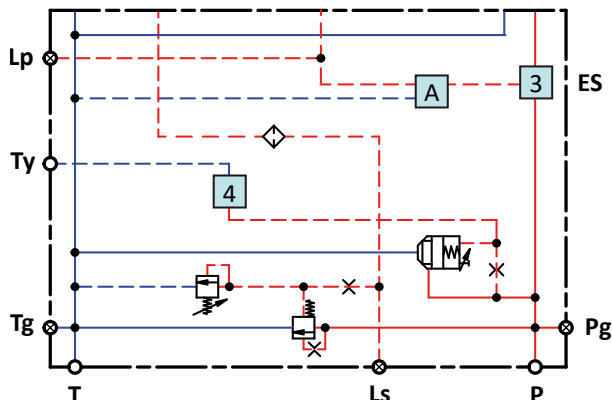
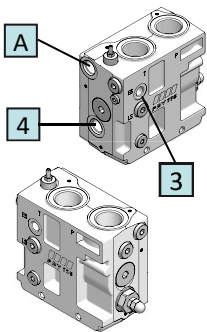

With pilot oil supply for electrically and hydraulic actuated valves **3** and pump unloading system **4**

Code numbers	
PDI01A42000	PDI01A42010
BSP	UN-UNF
Connections thread see page 249	

Product

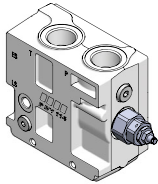

Hydraulic diagram

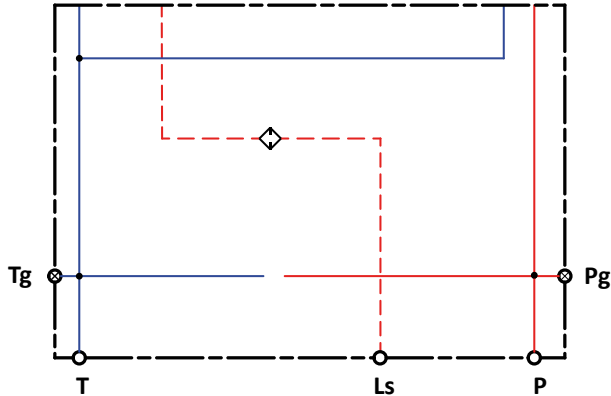

Description

For mechanically actuated valves, only

Code numbers

PDI01C3000

PDI01C30010

BSPP

UN-UNF

Connections thread see page [249](#)

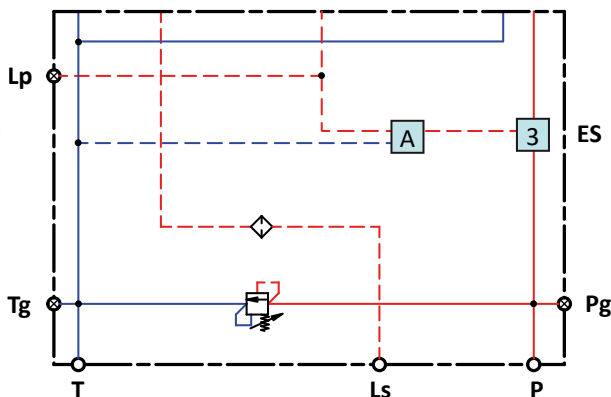
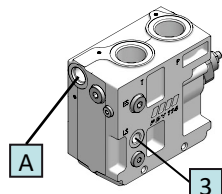

With pilot oil supply for electrically and hydraulic actuated valves [3](#)

Code numbers

PDI01C4000

PDI01C40010

BSPP

UN-UNF

Connections thread see page [249](#)

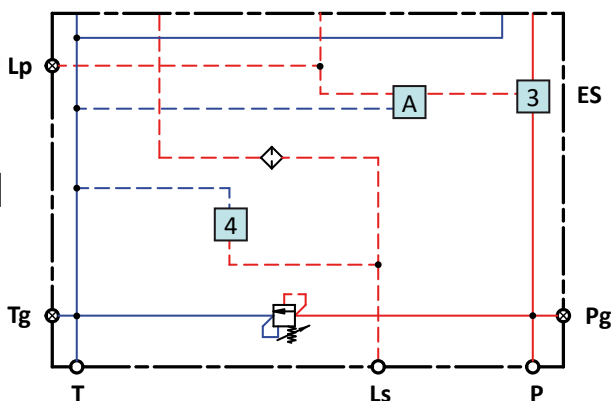
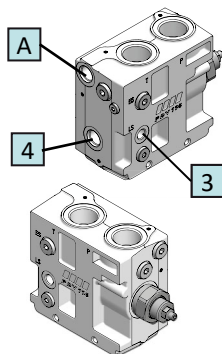

With pilot oil supply for electrically and hydraulic actuated valves [4](#) and facility for LS unloading [3](#)

Code numbers

PDI01C4100

PDI01C41010

BSPP

UN-UNF

Connections thread see page [249](#)

Product

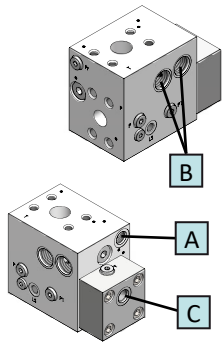

Hydraulic diagram

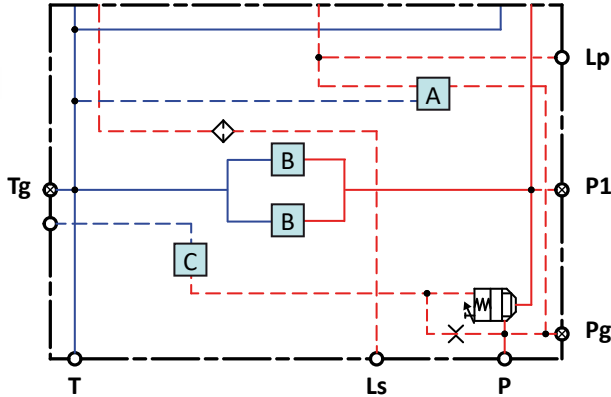

Description

With pilot oil supply for electrically and hydraulic actuated valves **3** and cut-off system

Code numbers

PDI01C44000

PDI01C44010

BSP

UN-UNF

Connections thread see page [249](#)

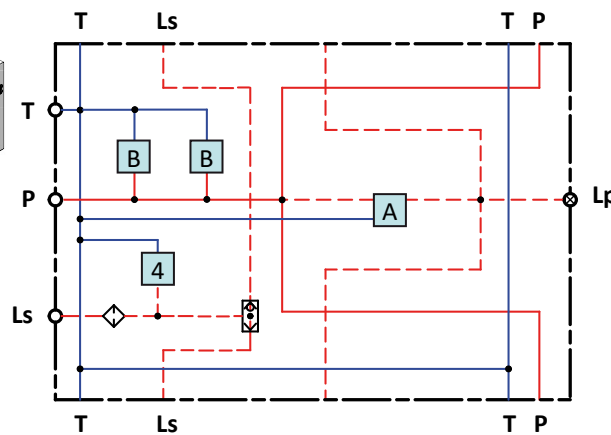
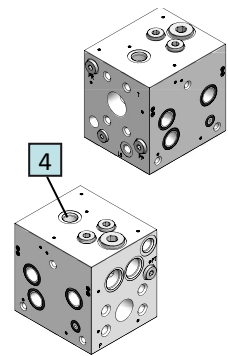

MID inlet PDV114 with pilot oil supply for electrically and hydraulic actuated valves and facility for LS unloading **4**

Code numbers

PDIM1C41000

PDIM1C41010

BSP

UN-UNF

Connections thread see page [261](#)

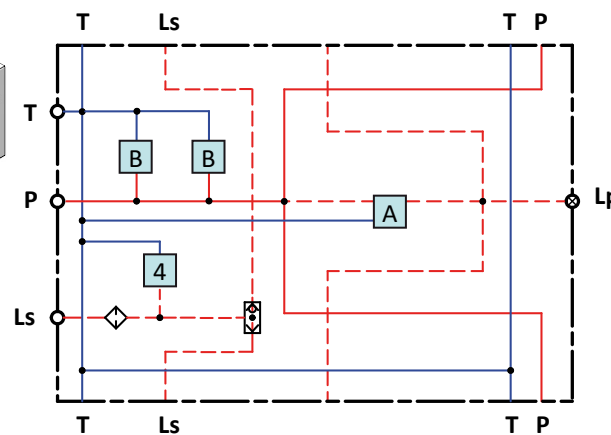
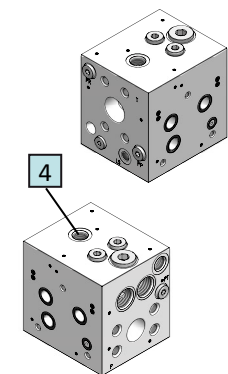

MID inlet PDV117 with pilot oil supply for electrically and hydraulic actuated valves and facility for LS unloading **4**

Code numbers

PDIM4C41000

PDIM4C41010

BSP

UN-UNF

Connections thread see page [166](#)

DIN 43650A

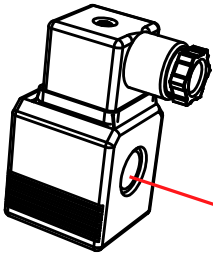

Deutsch Parallel

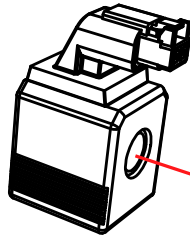

Deutsch Perpendicular

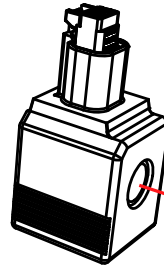

Junior Power Timer

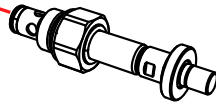
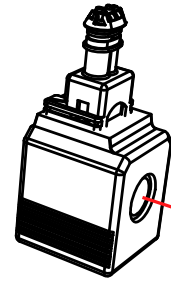

Normally closed
 Emergency: screw

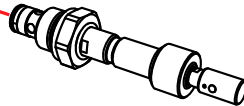



Normally open
 Emergency: push and twist

Code numbers

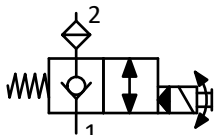
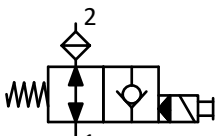
PIU solenoid LS unloading valve codes

Code numbers			
PIU solenoid LS unloading valve codes			
Cartridge valve type	Connector type	12 Vdc	24 Vdc
Normally closed Emergency: screw 	DIN 43650A	PIU0C023200	PIU0C013200
	Deutsch Parallel	PIU0C021200	PIU0C011200
	Deutsch Perpendicular	PIU0C022200	PIU0C012200
	Junior Power Timer	PIU0C024200	PIU0C014200
Normally open Emergency: push and twist 	DIN 43650A	PIU0A023100	PIU0A013100
	Deutsch Parallel	PIU0A021100	PIU0A011100
	Deutsch Perpendicular	PIU0A022100	PIU0A012100
	Junior Power Timer	PIU0A024100	PIU0A014100

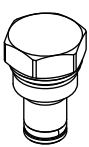
Plug for LS unloading cavity

Plug cavity	Hydraulic scheme	Code numbers
		<p>PIP10000000</p>

Max. operating pressure	350 bar	
Max. internal leakage	350 bar, 46 mm²/sec 1 cm³/min	
max pressure drop	< 1,5 bar	
Expected life - 350 bar, 0,5 Hz (1s on / 1s off)	10.000.000 cycles	
Response time for LS pressure relief	< 280ms	
Oil temperature	Recommended	30 ÷ 60 °C
	Min.	-30 °C
	Max.	90 °C
Ambient temperature	-30 ÷ 60 °C	
Max. coil surface temperature	160 °C	
Oil viscosity	Operating range	10 ÷ 90 cSt
	Min.	4 mm²/sec
	Max.	460 mm²/sec
Degree of enclosure	Connector DIN 43650	IP65
	Connector Deutsch DT04-2p	IP67
		IP69K integrated to coil
Rated voltage	12 Vdc	24 Vdc
Supply voltage	10,6 ÷ 14,6 Vdc	20,4 ÷ 28,6 Vdc
Working temperature	-30 ÷ 80 °C	
Maximum coil surface temperature	175 °C	
Heat insulation	Class H (180 °C)	
Resistance	7,5 Ω	29,9 Ω
Current consumption	1,6 A	0,8 A
Power consumption	19 W	

Product

Hydraulic diagram

Description

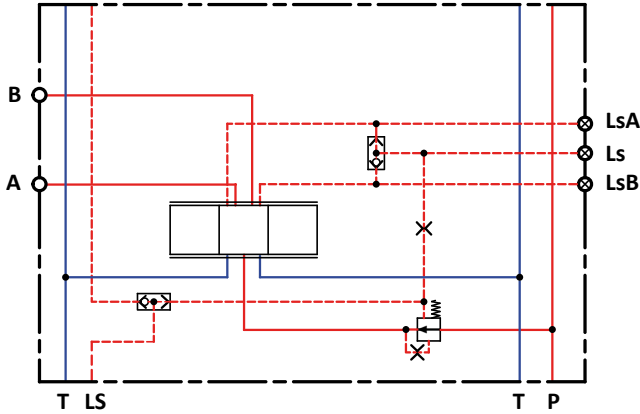
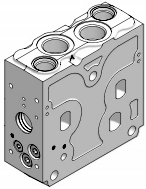

<p>No facilities for shock-suction valves No facilities for LS A/B pilot relief valves</p>	
Code numbers	
PDW1100000	PDW1100010
BSP	UN-UNF
A/B ports 3/4" Ls-LsA-LsB remote pressure connections 1/4"	A/B ports 1-1/16"-12UNF-2B Ls-LsA-LsB remote pressure connections 7/16"-20UNF-2B

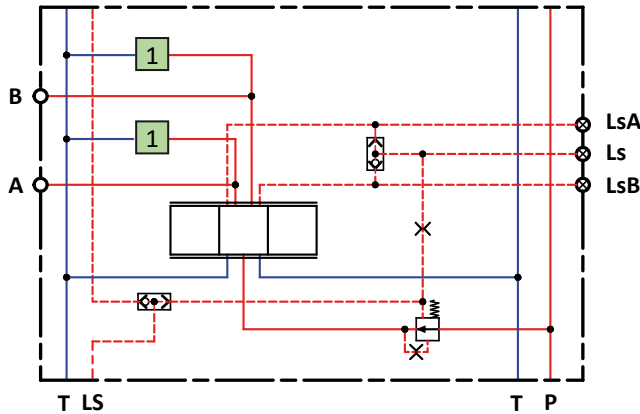
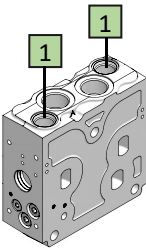

<p>Facilities for shock-suction valves 1 No facilities for LS A/B pilot relief valves</p>	
Code numbers	
PDW1101000	PDW1101010
BSP	UN-UNF
A/B ports 3/4" Ls-LsA-LsB remote pressure connections 1/4"	A/B ports 1-1/16"-12UNF-2B Ls-LsA-LsB remote pressure connections 7/16"-20UNF-2B

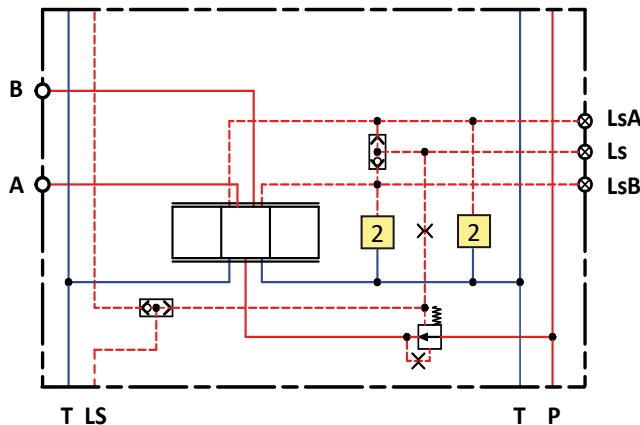
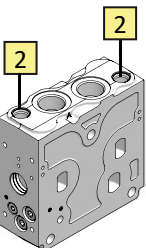

<p>No facilities for shock-suction valves Facilities for LS A/B pilot relief valves 2</p>	
Code numbers	
PDW1110000	PDW1110010
BSP	UN-UNF
A/B ports 3/4" Ls-LsA-LsB remote pressure connections 1/4"	A/B ports 1-1/16"-12UNF-2B Ls-LsA-LsB remote pressure connections 7/16"-20UNF-2B

Product

Hydraulic diagram

Description

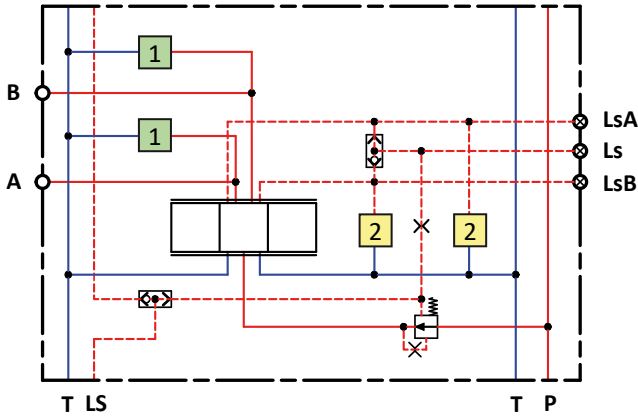
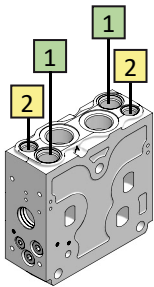

Facilities for shock-suction valves 1	
Facilities for LS A/B pilot relief valves 2	
Code numbers	
PDW11110000	PDW11110010
BSP	UN-UNF
A/B ports 3/4" Ls-LsA-LsB remote pressure connections 1/4"	A/B ports 1-1/16"-12UNF-2B Ls-LsA-LsB remote pressure connections 7/16"-20UNF-2B

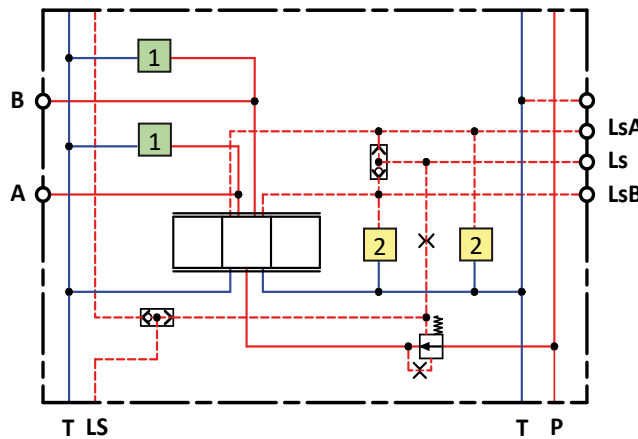
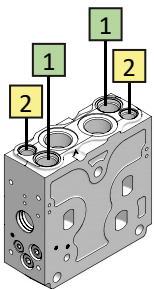

Facilities for shock-suction valves 1	
Facilities for LS A/B pilot relief valves and electric unloading LS A/B piloting 2	
Code numbers	
PDW11111000	PDW11111010
BSP	UN-UNF
A/B ports 3/4" Ls-LsA-LsB remote pressure connections 1/4"	A/B ports 1-1/16"-14UNF-2B Ls-LsA-LsB remote pressure connections 7/16"-20UNF-2B

Product

Hydraulic diagram

Description

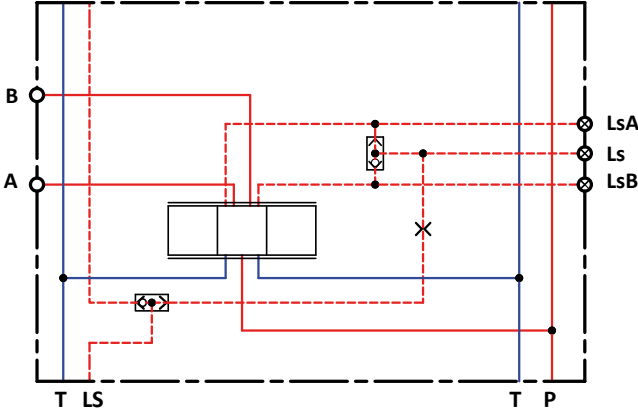
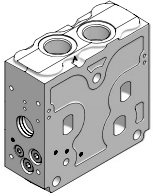

No facilities for shock-suction valves	
Code numbers	
PDW1000000	PDW1000010
BSP	UN-UNF
A/B ports 3/4" Ls-LsA-LsB piloting connections 1/4"	A/B ports 1-1/16"-12UNF-2B Ls-LsA-LsB piloting connections 7/16" - 20UNF - 2B

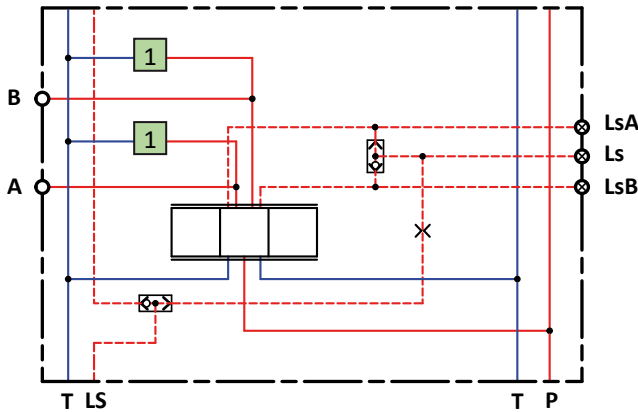
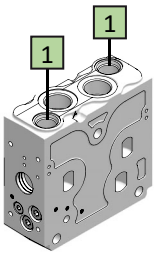

Facilities for shock-suction valves 1	
Code numbers	
PDW1001000	PDW1001010
BSP	UN-UNF
A/B ports 3/4" Ls-LsA-LsB piloting connections 1/4"	A/B ports 1-1/16"-12UNF-2B Ls-LsA-LsB piloting connections 7/16" - 20UNF - 2B

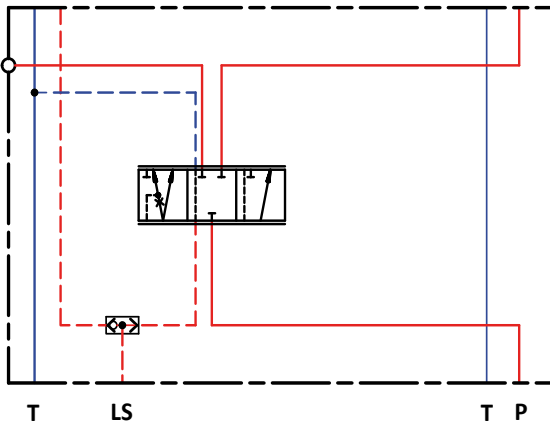
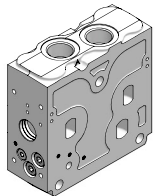

Functional safety cut off system and diverter flow	
Code numbers	
PDW1500000	PDW1500010
BSP	UN-UNF
A/B ports 3/4" Ls-LsA-LsB piloting connections 1/4"	A/B ports 1-1/16"-12UNF-2B Ls-LsA-LsB piloting connections 7/16" - 20UNF - 2B

Product

Hydraulic diagram

Description

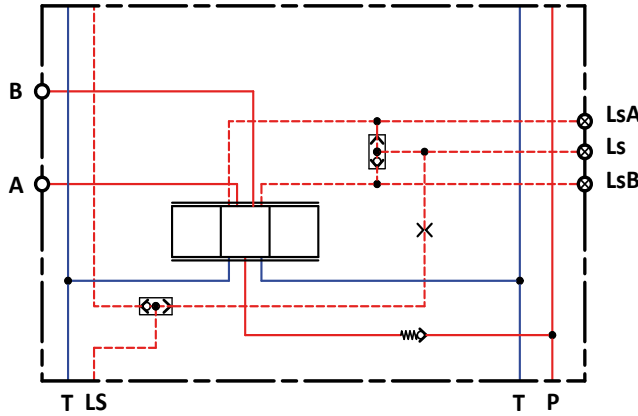
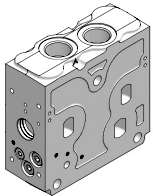

No facilities for shock-suction valves With load drop check valve on P channel	
Code numbers	
PDW1300000	PDW1300010
BSP	UN-UNF
A/B ports 3/4" Ls-LsA-LsB piloting connections 1/4"	A/B ports 1-1/16"-12UNF-2B Ls-LsA-LsB piloting connections 7/16" - 20UNF - 2B

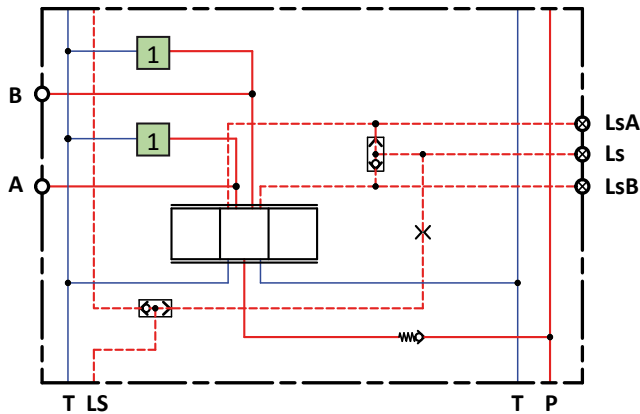
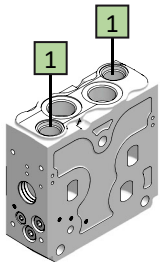

Facilities for shock-suction valve 1 With load drop check valve on P channel	
Code numbers	
PDW1301000	PDW1301010
BSP	UN-UNF
A/B ports 3/4" Ls-LsA-LsB piloting connections 1/4"	A/B ports 1-1/16"-12UNF-2B Ls-LsA-LsB piloting connections 7/16" - 20UNF - 2B

Product

Hydraulic diagram

Description

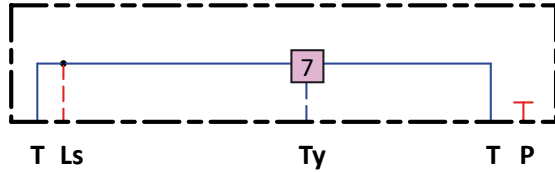
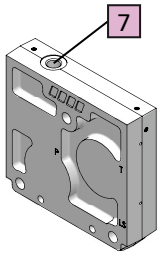

No ported, prearranged for external/internal drain 7	
Code numbers	
PDE01010000	PDE01010010
BSPP	UN-UNF
Connections thread see page 249	

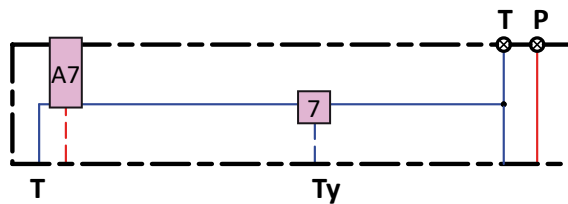
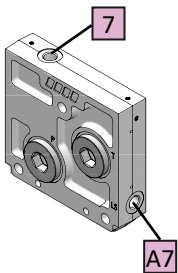

Ls port A7 prearranged for external/internal drain 7	
Code numbers	
PDE01210000	PDE01210010
BSPP	UN-UNF
Connections thread see page ____	

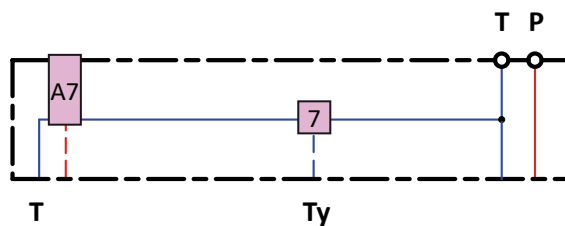
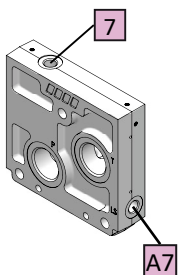

P-T-Ls ports A7 prearranged for external/internal drain 7	
Part number	
PDE01110000	PDE01110010
BSPP	UN-UNF
Connections thread see page ____	

Product

Hydraulic diagram

Description

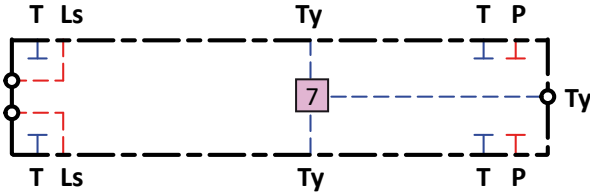
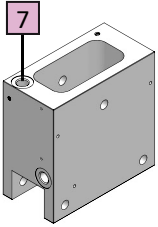

Mid End PDV114 7	
Code numbers	
PDEM1010000	PDEM1010010
BSPP	UN-UNF
Connections thread see page 255	

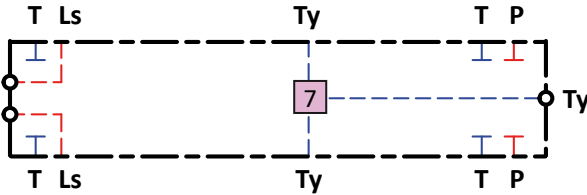
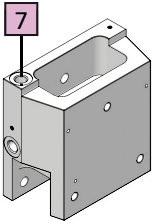

Mid End PDV117 7	
Code numbers	
PDEM4010000	PDEM4010010
BSPP	UN-UNF
Connections thread see page 265	

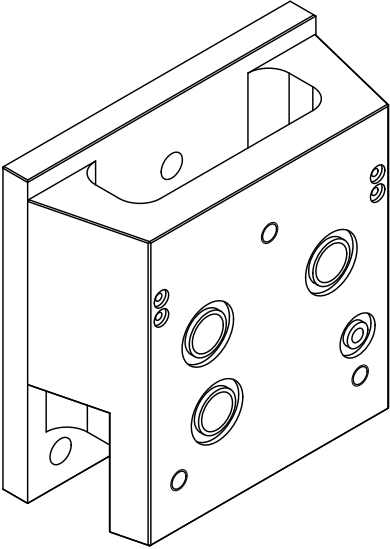
	Description	PDEI4000000

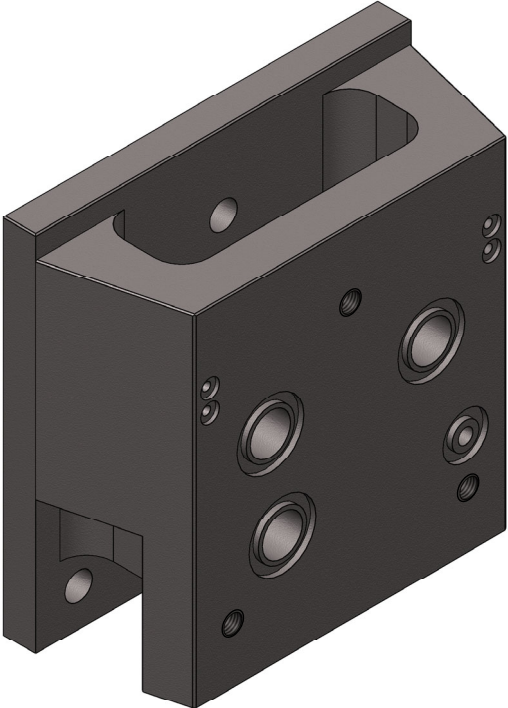

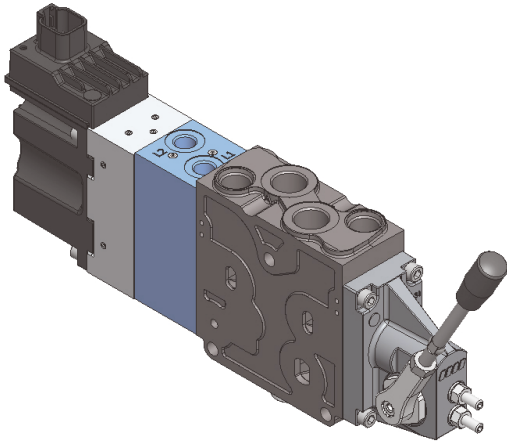

PDZ is a small HIC body that can be matched with any kind of PDV114 working section PDW, to get hydraulic and electro-hydraulic spool control

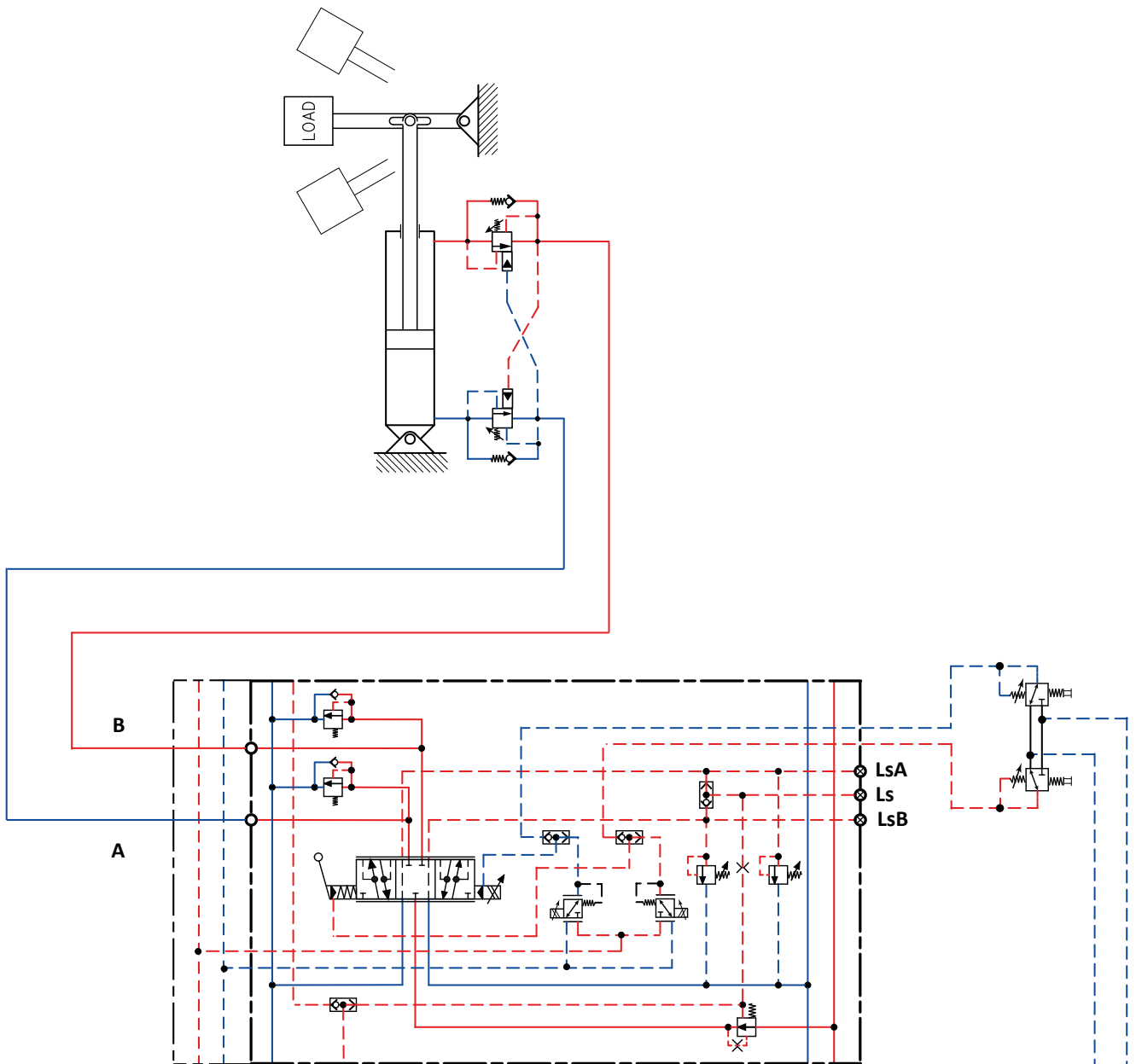

PDZ overall dimensions	For open loop spool control (Aluminium)	For closed loop spool control (Cast Iron)
	<p align="center">PDZ10000000 1/4" BSPP - 12 mm deep</p>	<p align="center">PDZ 1/4" BSPP - 12 mm deep</p>
	<p align="center">PDZ [7/16 in-20 UNF-2B - 0,47 in deep]</p>	<p align="center">PDZ [7/16 in-20 UNF-2B - 0,47 in deep]</p>

Oil flow characteristics

With flow control spool, the oil flow depends on type of PDW module (with or without pressure compensator) and type of pump (fixed or variable displacement).

In the below chart, the ordinate numbers refer to spool size, and the ordinal numbers refer to the same spool size but fitted in a different position with related lost flow.

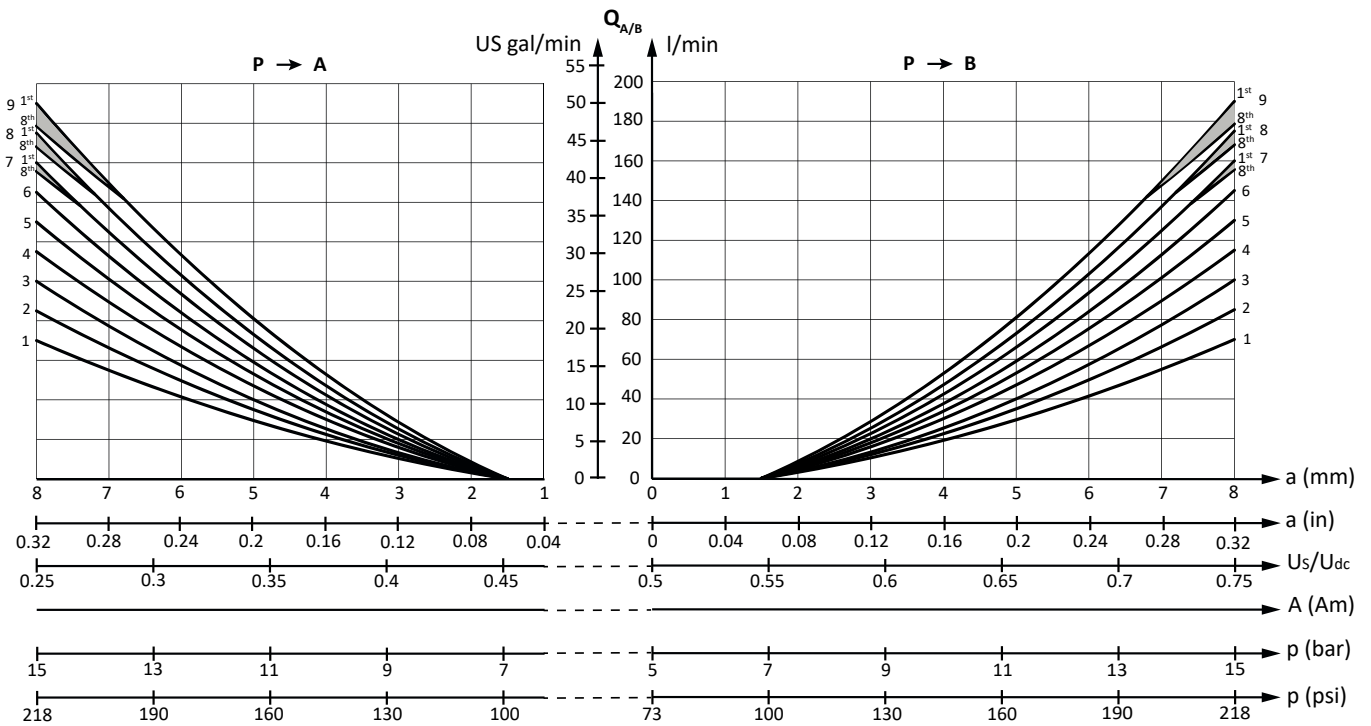
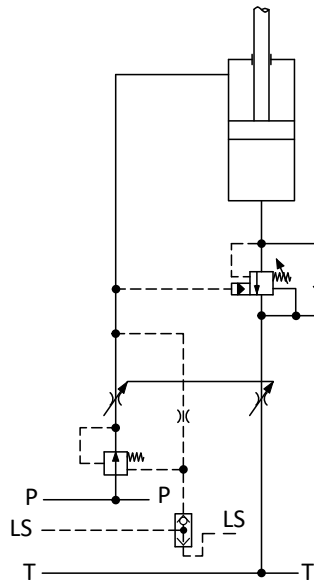

Double acting flow control spool

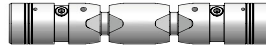

Size	Max oil flow pressure compensated l/min	Code numbers and symbol			
		4-way, 3-position - A, B closed	4-way, 3-position, A, B → T	4-way, 3-position, B → T; A closed	4-way, 3-position, A → T; B closed
1	70	PDS01110101	PDS01120102		
2	85	PDS01110103	PDS01120104		
3	100	PDS01110105	PDS01120106		
4	115	PDS01110107	PDS01120108		
5	130	PDS01110109	PDS01120110		
6	145	PDS01110111	PDS01120112		
7	160	PDS01110117	PDS01120118		
8	175	PDS01110119	PDS01120120		
9	190	PDS01110121	PDS01120122		

Double acting asymmetric flow control spool



Max oil flow pressure compensated l/min		Code numbers and symbol			
A	B	4-way, 3-position - A, B closed	4-way, 3-position, A, B → T	4-way, 3-position, B → T, A closed	4-way, 3-position, A → T, B closed
190	70	PDS01130101	PDS01130102		
190	115	PDS01130103	PDS01130104		
70	190	PDS01130105	PDS01130106		
115	190	PDS01130107	PDS01130108		

Single acting flow control spool

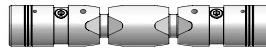

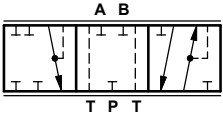
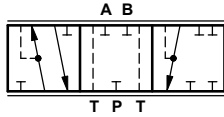
Size	Max oil flow pressure compensated l/min	Symbol and code numbers	
			
		3-way, 3-position P → A	3-way, 3-position P → B
1			
2			
3			
4			
5			
6			
7			
8			
9			

Double acting flow control spool, floating position

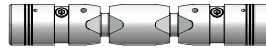

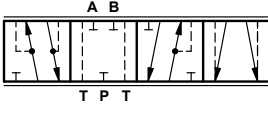
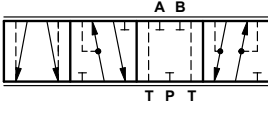
Size	Max oil flow pressure compensated l/min	Symbol and code numbers	
			
		3-way, 4-position floating position on A port	3-way, 4-position floating position on B port
1			
2			
3			
4			
5			

Spool centered set, code numbers (needed for any kind of flow control spool)

Tightening torque		Tightening torque
6 ⁺¹ ₀ Nm		6 ⁺¹ ₀ Nm
53,1 ^{+8,85} ₀ lb*in		53,1 ^{+8,85} ₀ lb*in
Manual control	PDR10300101	
Hydraulic - Electrohydraulic	PDR10300102	

Double acting flow control, regenerative function

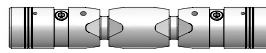

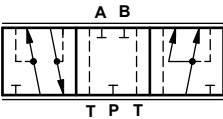
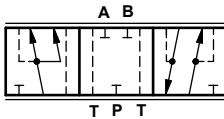
Size	Max oil flow pressure compensated l/min	Symbol and code numbers	
			
		Regenerative circuit on A port	Regenerative circuit on B port
1	70		
2	85		
3	100		
4	115		
5	130		
6	145		
7	160		
8	175		
9	190		
10			

Spool centered set, code numbers (needed for any kind of flow control spool)

Tightening torque		Tightening torque
6 ⁺¹ ₀ Nm		6 ⁺¹ ₀ Nm
53,1 ^{+8,85} ₀ lb*in		53,1 ^{+8,85} ₀ lb*in
Manual control	PDR10300101	
Hydraulic - Electrohydraulic	PDR10300102	

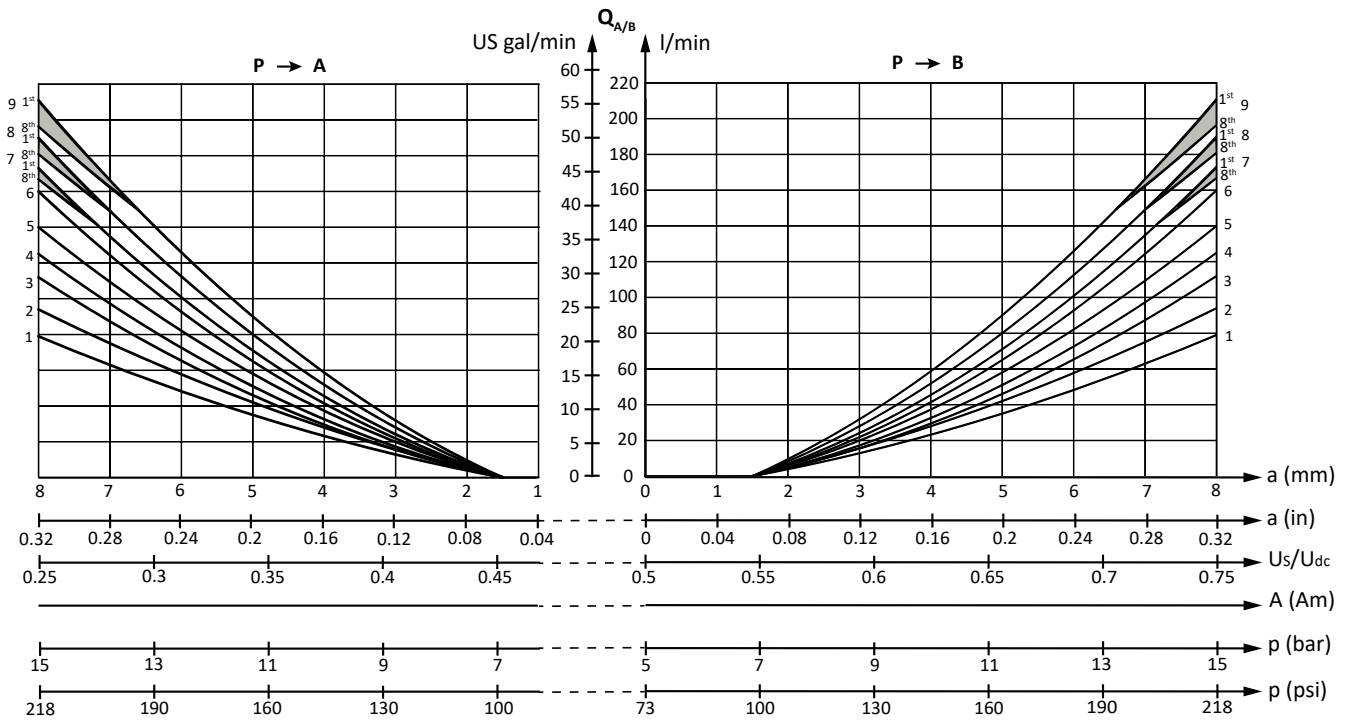

Oil flow characteristics PDW without pressure compensator, and pump differential pressure setting = 16 bar

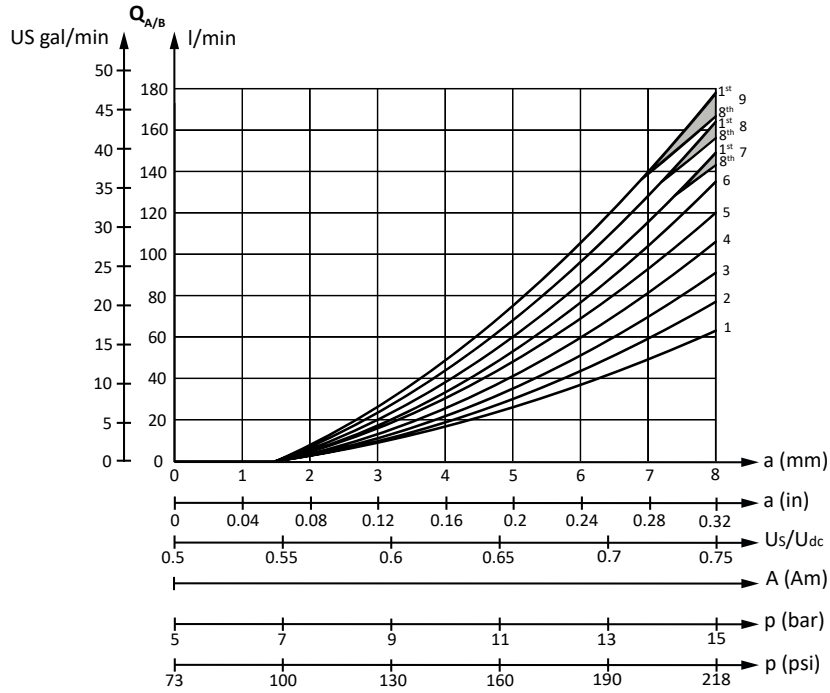

Oil flow characteristics PDW without pressure compensator, and pump differential pressure setting = 25 bar

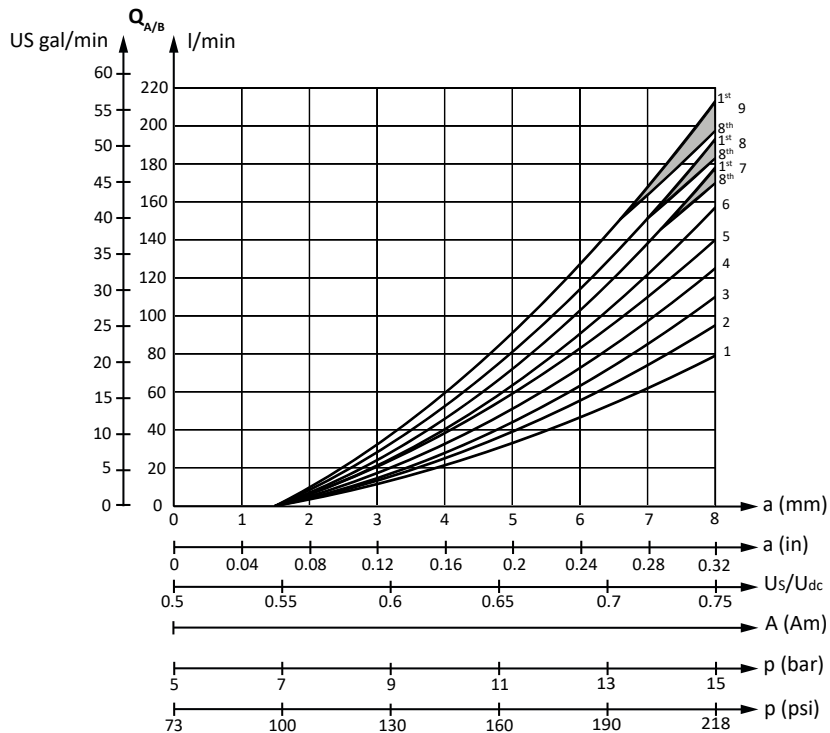

Oil flow PDW pressure compensated with LS A/B pilot relief valves

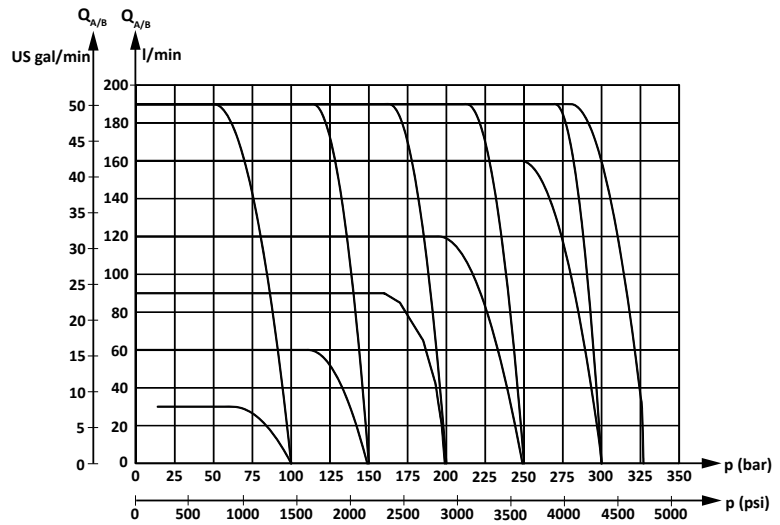

Load independent oil flow pressure compensated PDW

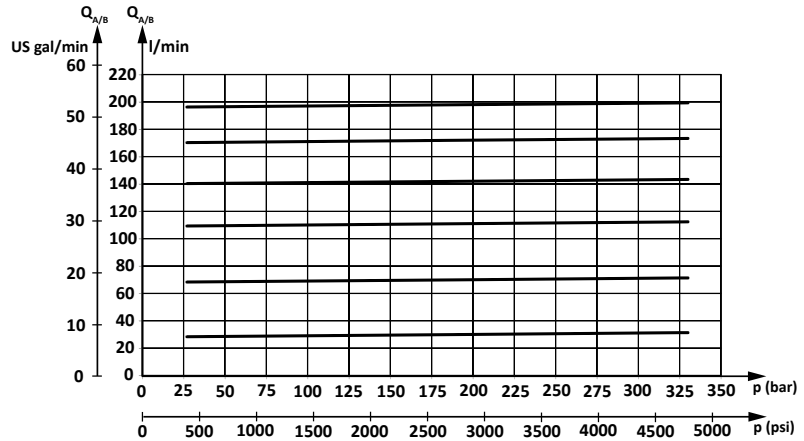

PDW pressure drop at max main spool travel

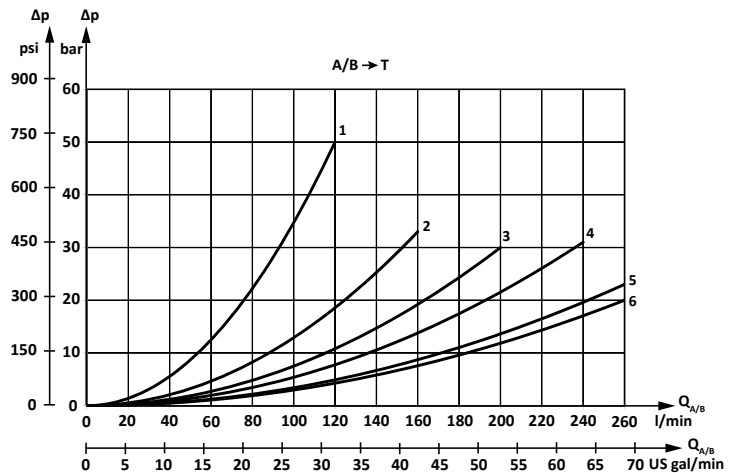

By using proportional directional valves along with overcenter valves, instability problems may occur in the form of pressure surging.

To solve these problems, spools with different circuit named "Pressure Control" have been developed.

The main purpose of these spools, is to hold in position the 2-way pressure compensator, preventing it from going into unstable condition, and in turn, to keep the overcenter's pilot pressure value as stable as possible.

Pressure control spools, must always be used with pressure compensated working sections equipped with pilot LS A/B relief valves.

Pressure control spool, normally give a higher degree of stability to whole hydraulic system, however, we advise to look after their use, because:

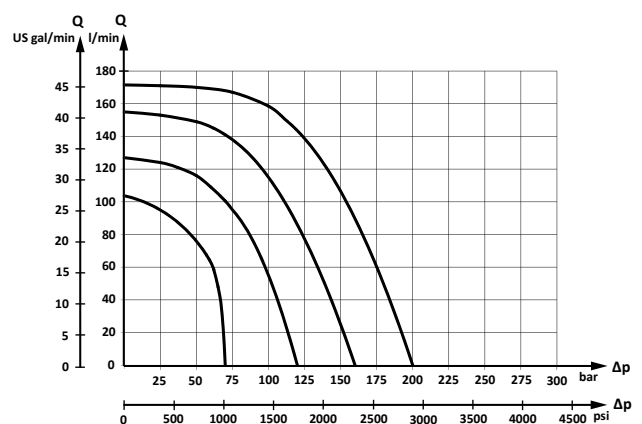
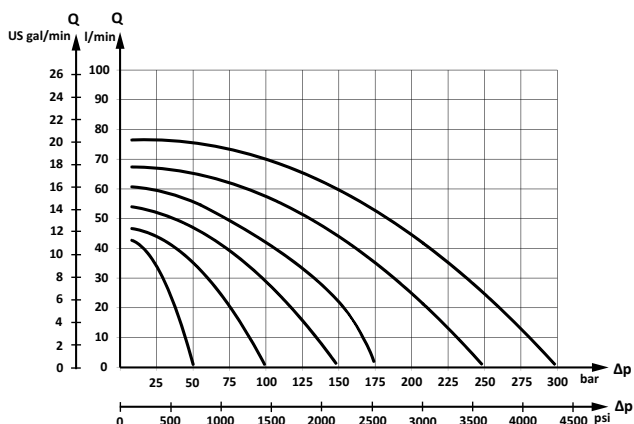
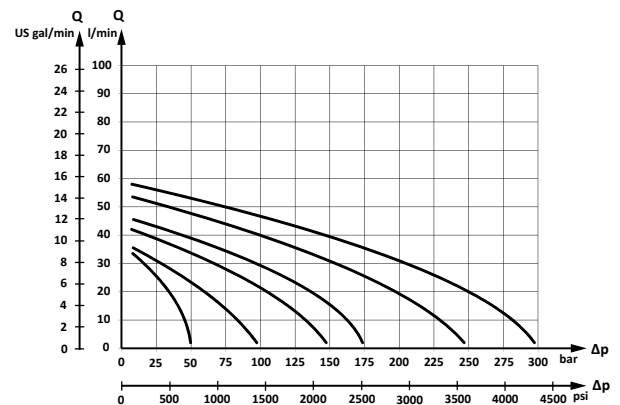
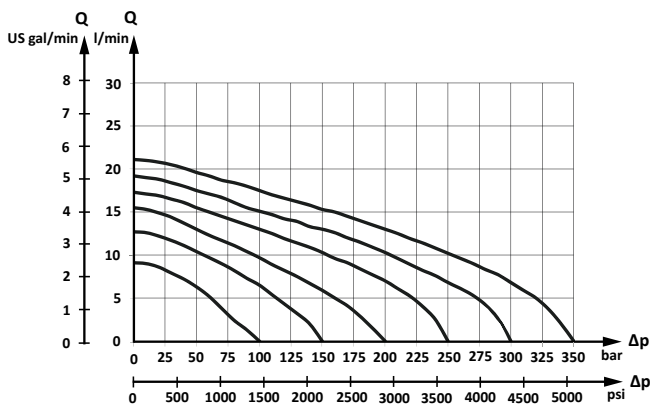
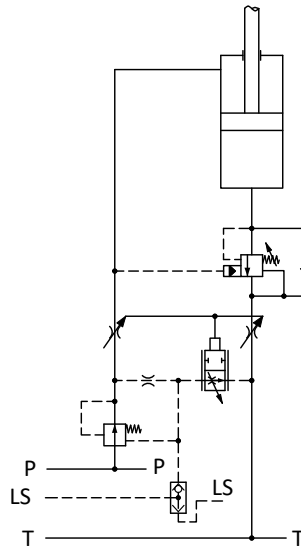

- The valve may lose a bit of pressure compensation, becoming load dependent.
- The pump pressure may be considerably higher than that necessary to move the load.

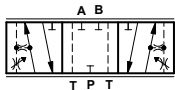
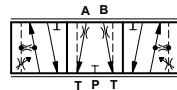
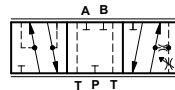
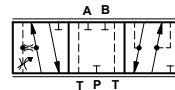
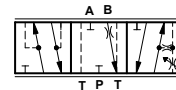
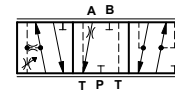



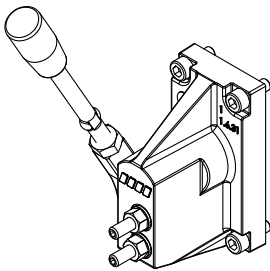
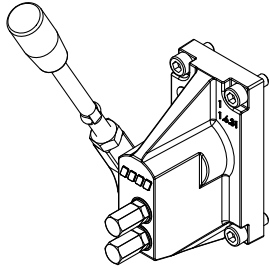
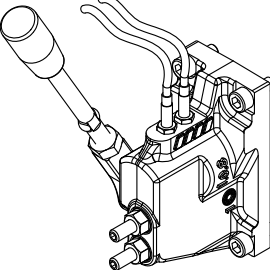
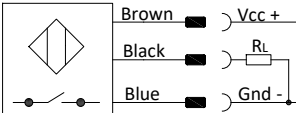
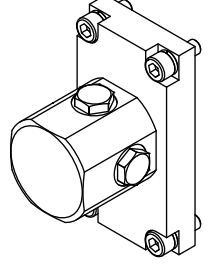
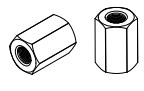

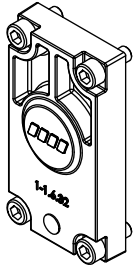
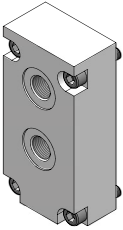
Pressure control spool						
						
Symbol and code numbers (PC = Pressure control - FC = Flow control)						
Size						
	4-way, 3-position, A, B closed	4-way, 3-position, A, B throttled open to T	4-way, 3-position, A, B closed	4-way, 3-position, A, B closed	4-way, 3-position, A throttled open to T, B closed	4-way, 3-position, A closed, B throttled open to T
1	PDS PC→A + B	PDS PC→A + B	PDS PC→A FC→B, Q=--l/min	PDS PC→B FC→A, Q=--l/min	PDS PC→A FC→B, Q=--l/min	PDS PC→B FC→A, Q=--l/min
	-	-	PDS PC→A FC→B, Q=--l/min	-	-	-
2	PDS PC→A + B	PDS PC→A + B	PDS PC→A FC→B, Q=--l/min	PDS PC→B FC→A, Q=--l/min	PDS PC→A FC→B, Q=--l/min	PDS PC→B FC→A, Q=--l/min
3	PDS PC→A + B	PDS PC→A + B	PDS PC→A FC→B, Q=--l/min	PDS PC→B FC→A, Q=--l/min	PDS PC→A FC→B, Q=--l/min	PDS PC→B FC→A, Q=--l/min
3,5	PDS PC→A + B	PDS PC→A + B	PDS PC→A FC→B, Q=--l/min	PDS PC→B FC→A, Q=--l/min	PDS PC→A FC→B, Q=--l/min	PDS PC→B FC→A, Q=--l/min
4	PDS PC→A + B	PDS PC→A + B	PDS PC→A FC→B, Q=--l/min	PDS PC→B FC→A, Q=--l/min	PDS PC→A FC→B, Q=--l/min	PDS PC→B FC→A, Q=--l/min

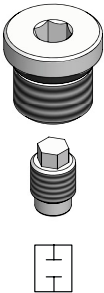
Spool centered set, code numbers (needed for any kind of flow control spool)		
Tightening torque		Tightening torque
6 ⁺¹ ₀ Nm		6 ⁺¹ ₀ Nm
53,1 ^{+8,85} ₀ lb*in		53,1 ^{+8,85} ₀ lb*in
Manual control	PDR10300101	
Hydraulic - Electrohydraulic	PDR10300102	

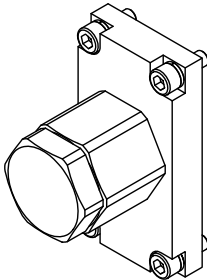
Product	Description	Aluminium	Cast iron
PDM 	Mechanical actuation	With lever	
		PDM20101000	PDM21101000
		Without lever	
		PDM20100000	PDM21100000
PDM 	Mechanical actuation, with flow adjustment nuts protection	With lever	
		PDM20201000	PDM21201000
		Without lever	
		PDM20200000	PDM21200000
PDM 	Mechanical actuations with directional sensors for electrical monitoring of spool valve movement  Vcc 10 V ... 30 V I < 200 mA	With lever	
		Normally closed:	PDM21111000
		Normally open:	PDM21121000
PDF 	Friction detent (for mechanical actuation only)	Cast iron only	
		PDF11000000	
	Flow adjustment protection nuts for PDM mechanical control		

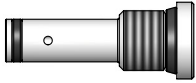
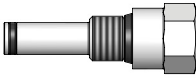
Product	Description	Aluminium	Cast iron
PDC 	Rear cover for mechanical actuation	PDC00010000	PDC10010000
PDH 	Hydraulic actuation	A/B pilot port 1/4 BSPP deep: 12 mm (0,47 in) PDH10000000	A/B pilot port 1/4 BSPP deep: 12 mm (0,47 in) PDH11000000
		A/B pilot port 7/16-20UNF-2B deep: 12 mm (0,47 in) PDH10000100	A/B pilot port 7/16-20UNF-2B deep: 12 mm (0,47 in) PDH11000100
	Pilot LS _{A/B} relief valve	50 ÷ 80 bar	PLS0A100000
		81 ÷ 380 bar	PLS0A400000
	Plug for pilot LS _{A/B} relief valve cavity	PLS0P000000	

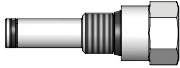
Product	Description	Cast iron only
<p style="text-align: center;">PDD</p> 	<p style="text-align: center;">Mechanical spool lock device, manual release</p>	<p>P→A - lock P→B - free PDD10100000</p>
		<p>P→A - free P→B - lock PDD10010000</p>
		<p>P→A - lock P→B - lock PDD10110000</p>
		<p>P→A - float P→B - free PDD10200000</p>
		<p>P→A - free P→B - float PDD10020000</p>

Product	Description	Code numbers	
<p>PIZ</p> 	For PDI with internal pilot oil supply	PIZ10000000	
<p>PIY</p> 	For PDI with external pilot oil supply	A/B pilot port 1/4 BSPP deep: 12 mm (0,47 in) PIY10000000	A/B pilot port 7/16-20UNF-2B deep: 12 mm (0,47 in) PIY10000010
	For PDE with external drain line electrical actuation	A/B pilot port 1/4 BSPP deep: 12 mm (0,47 in) PED10000000	A/B pilot port 7/16-20UNF-2B deep: 12 mm (0,47 in) PED10000010
	For PDE with internal drain line electrical actuation	PEI10000000	
	For PDE with LS carry-over	A/B pilot port 1/4 BSPP deep: 12 mm (0,47 in) PED20000000	A/B pilot port 7/16-20UNF-2B deep: 12 mm (0,47 in) PED20000010
	For PDE prearranged LS carry-over	PEI10000000	

PWS, PWA and **PWB** are shock suction valves design to absorb shock effects only, and they should never be used as a pressure relief valves.
PWS, PWA and **PWB** are set at an oil flow of 10 l/min. If the hydraulic actuator requires a pressure relief valve function, a PDW module with built-in LS_{A/B} pilot pressure limit valves should be used

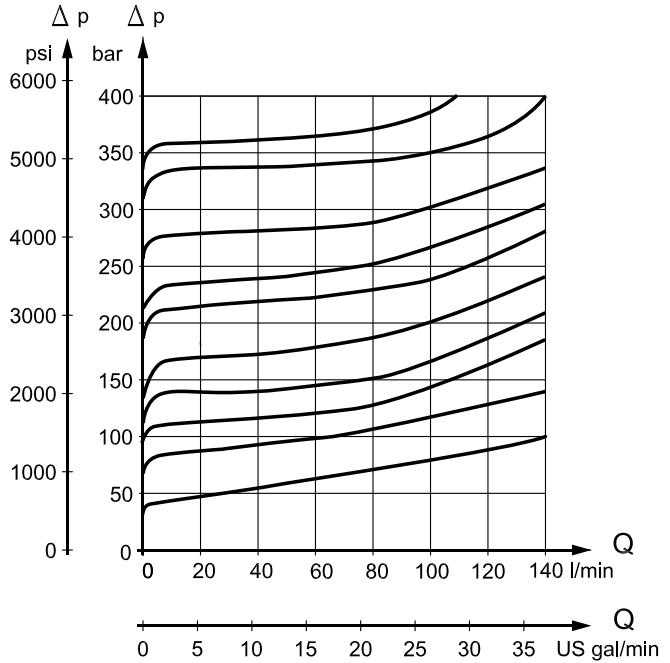

PWR suction valve

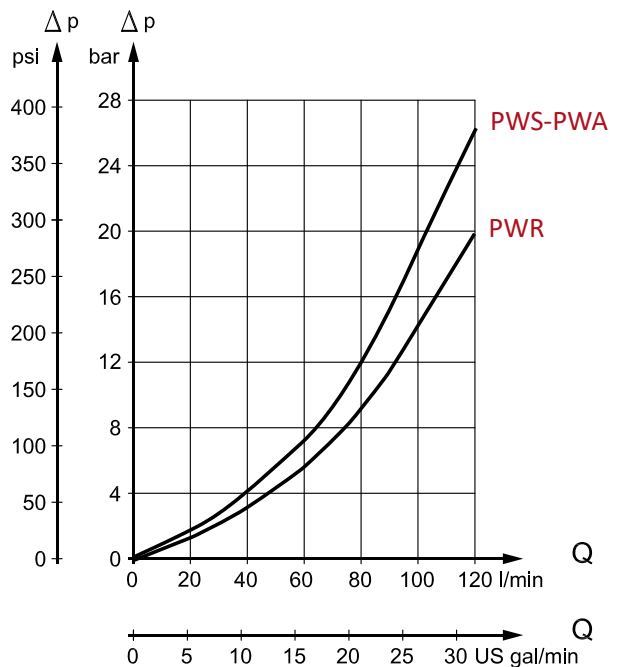

PWS shock and suction valve for A/B port. Not adjustable

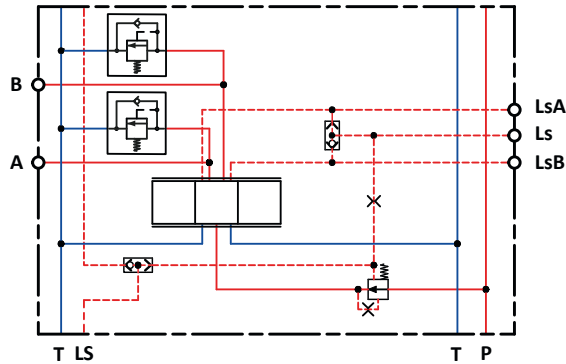
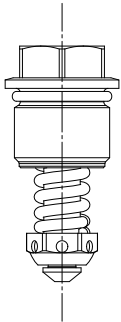

Setting Pressure(bar)	Code numbers
50	PWS1M200050
70	PWS1M200070
90	PWS1M200090
110	PWS1M200110
130	PWS1M200130
150	PWS1M200150
180	PWS1M200180
200	PWS1M200200
230	PWS1M200230
260	PWS1M200260
290	PWS1M200290
320	PWS1M200320
350	PWS1M200350
380	PWS1M200380

PWA shock and suction valve for A/B port. Adjustable

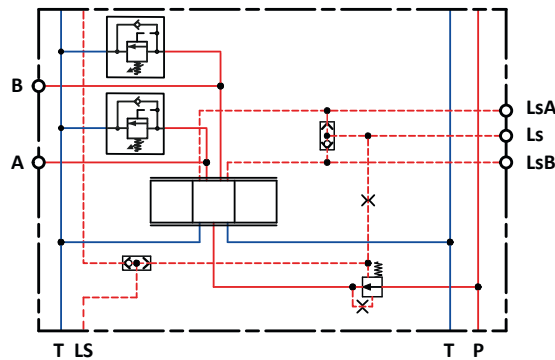
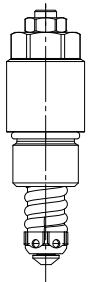



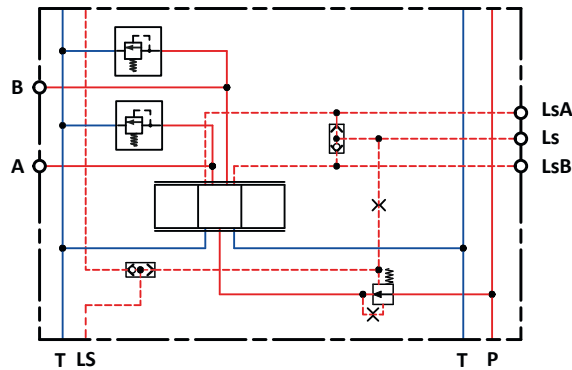
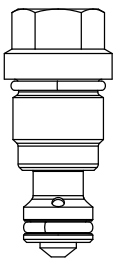

Range setting (bar)	Code numbers
20 ÷ 100	PWA1M200S00
101 ÷ 170	PWA1M200T00
171 ÷ 250	PWA1M200F00
251 ÷ 350	PWA1M200C00
351 ÷ 420	PWA1M200R00

PWB shock valve for A/B port. Not adjustable

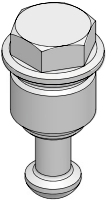

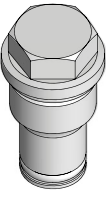
Setting pressure(bar)	Code numbers
50	PWB1M200050
70	PWB1M200070
90	PWB1M200090
110	PWB1M200110
130	PWB1M200130
150	PWB1M200150
180	PWB1M200180
200	PWB1M200200
230	PWB1M200230
260	PWB1M200260
290	PWB1M200290
320	PWB1M200320
350	PWB1M200350
380	PWB1M200380

PWR suction valve for A/B port		
Product	Hydraulic diagram	Code numbers
		PWR1M200000
Plug for PWS - PWA - PWB and PWR cavity		
Product	Hydraulic diagram	Code numbers
		PWP1M200000

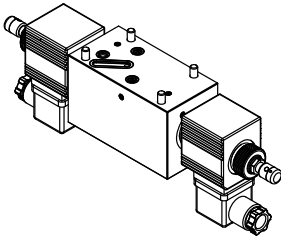

When PDL is energized, the piloting signal is lead to tank and in turn the work port oil flow will be cutted off.
 PDL modules is always to be matched with PDW pressure compensated.

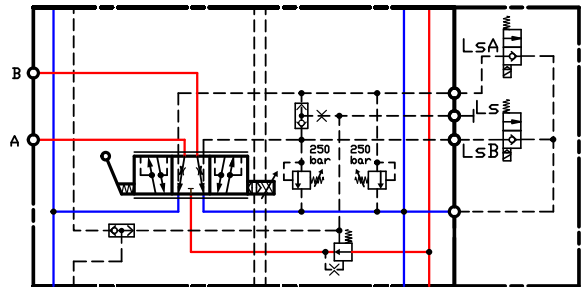
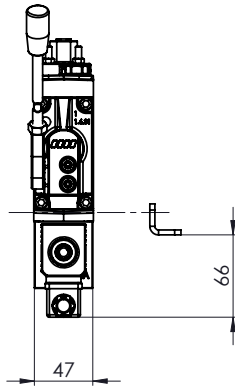
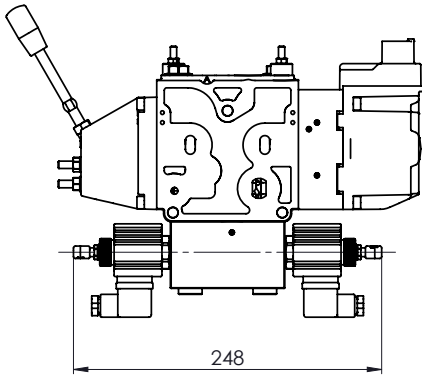

PDL code numbers			
Hydraulic diagram	Connector type	12V dc	24V dc
Active on LsA 	Deutsch Parallel	PDL12C11201	PDL12C31201
	Deutsch Perpendicular	PDL12C12201	PDL12C32201
	DIN	PDL12C13201	PDL12C33201
	JPT	PDL12C14201	PDL12C34201
Active on LsB 	Deutsch Parallel	PDL13C11201	PDL13C31201
	Deutsch Perpendicular	PDL13C12201	PDL13C32201
	DIN	PDL13C13201	PDL13C33201
	JPT	PDL13C14201	PDL13C34201
Active on LsA and LsB 	Deutsch Parallel	PDL11C11201	PDL11C31201
	Deutsch Perpendicular	PDL11C12201	PDL11C32201
	DIN	PDL11C13201	PDL11C33201
	JPT	PDL11C14201	PDL11C34201
Active on Ls 	Deutsch Parallel	PDL14C11201	PDL14C31201
	Deutsch Perpendicular	PDL14C12201	PDL14C32201
	DIN	PDL14C13201	PDL14C33201
	JPT	PDL14C14201	PDL14C34201

PDL code numbers			
Normally open module	Connector type	12V	24V
<p><i>Active on LsA</i></p>	Deutsch Parallel	PDL32A11101	PDL32A31101
	Deutsch Perpendicular	PDL32A12101	PDL32A32101
	DIN	PDL32A13101	PDL32A33101
	JPT	PDL32A14101	PDL32A34101
<p><i>Active on LsB</i></p>	Deutsch Parallel	PDL33A11101	PDL33A31101
	Deutsch Perpendicular	PDL33A12101	PDL33A32101
	DIN	PDL33A13101	PDL33A33101
	JPT	PDL33A14101	PDL33A34101
<p><i>Active on LsA and LsB</i></p>	Deutsch Parallel	PDL35A11101	PDL35A31101
	Deutsch Perpendicular	PDL35A12101	PDL35A32101
	DIN	PDL35A13101	PDL35A33101
	JPT	PDL35A14101	PDL35A34101
<p><i>Active on Ls</i></p>	Deutsch Parallel	PDL34A11101	PDL34A31101
	Deutsch Perpendicular	PDL34A12101	PDL34A32101
	DIN	PDL34A13101	PDL34A33101
	JPT	PDL34A14101	PDL34A34101

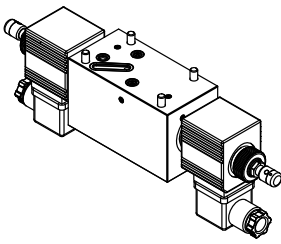

When PDL is deenergized, the piloting signal is lead to tank and in turn the work port oil flow will be cutted off.
 PDL modules is always to be matched with PDW pressure compesated.

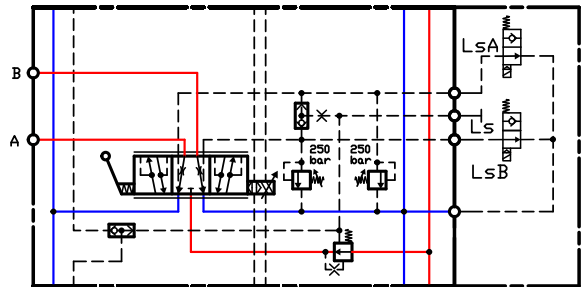
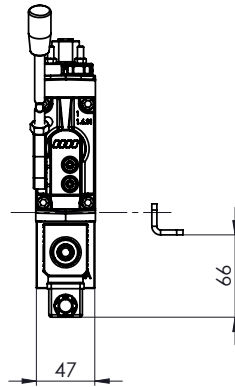
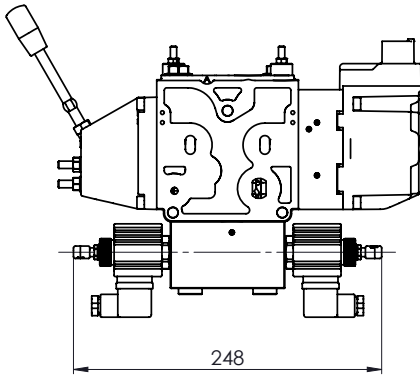

PDL code numbers			
Hydraulic diagram	Connector type	12V dc	24V dc
Active on L_SA 	Deutsch Parallel	PDL32A11101	PDL32A31101
	Deutsch Perpendicular	PDL32A12101	PDL32A32101
	DIN	PDL32A13101	PDL32A33101
	JPT	PDL32A14101	PDL32A34101
Active on L_SB 	Deutsch Parallel	PDL33A11101	PDL33A31101
	Deutsch Perpendicular	PDL33A12101	PDL33A32101
	DIN	PDL33A13101	PDL33A33101
	JPT	PDL33A14101	PDL33A34101
Active on L_SA and L_SB 	Deutsch Parallel	PDL35A11101	PDL35A31101
	Deutsch Perpendicular	PDL35A12101	PDL35A32101
	DIN	PDL35A13101	PDL35A33101
	JPT	PDL35A14101	PDL35A34101
Active on L_S 	Deutsch Parallel	PDL34A11101	PDL34A31101
	Deutsch Perpendicular	PDL34A12101	PDL34A32101
	DIN	PDL34A13101	PDL34A33101
	JPT	PDL34A14101	PDL34A34101

PDL code numbers			
Normally closed module	Connector type	12V	24V
<p style="text-align: center;"><i>Active on LsA</i></p>	Deutsch Parallel	PDL32C11201	PDL32C31201
	Deutsch Perpendicular	PDL32C12201	PDL32C32201
	DIN	PDL32C13201	PDL32C33201
	JPT	PDL32C14201	PDL32C34201
<p style="text-align: center;"><i>Active on LsB</i></p>	Deutsch Parallel	PDL33C11201	PDL33C31201
	Deutsch Perpendicular	PDL33C12201	PDL33C32201
	DIN	PDL33C13201	PDL33C33201
	JPT	PDL33C14201	PDL33C34201
<p style="text-align: center;"><i>Active on LsA and LsB</i></p>	Deutsch Parallel	PDL35C11201	PDL35C31201
	Deutsch Perpendicular	PDL35C12201	PDL35C32201
	DIN	PDL35C13201	PDL35C33201
	JPT	PDL35C14201	PDL35C34201
<p style="text-align: center;"><i>Active on Ls</i></p>	Deutsch Parallel	PDL34C11201	PDL34C31201
	Deutsch Perpendicular	PDL34C12201	PDL34C32201
	DIN	PDL34C13201	PDL34C33201
	JPT	PDL34C14201	PDL34C34201

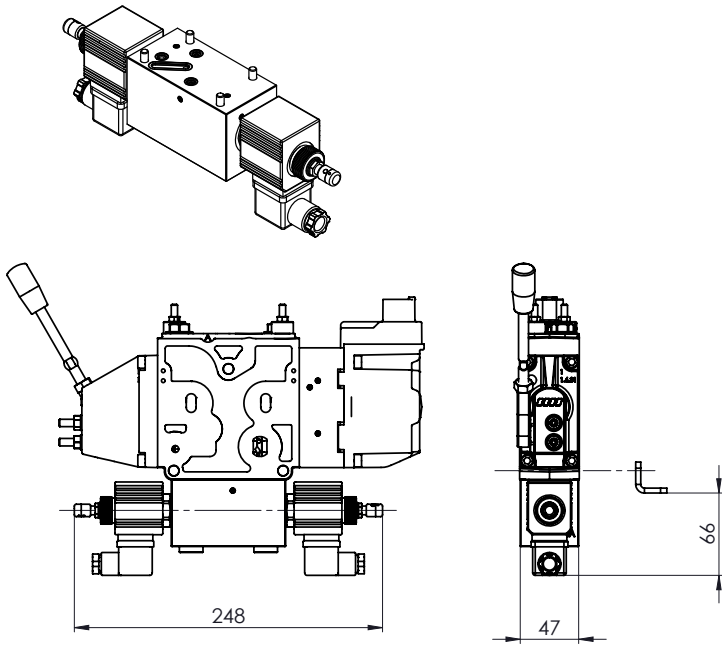

PDLD is an electro-hydraulic device that allows the A/B port working pressure to be remotely and proportionally operated according to a current signal (mA). When the working pressure exceeds the setting pressure value, the A/B port oil flow will be cutted off.

When PDLD is not energized, PDV is almost pressureless, as well as the A-B oil flow is cutted off.

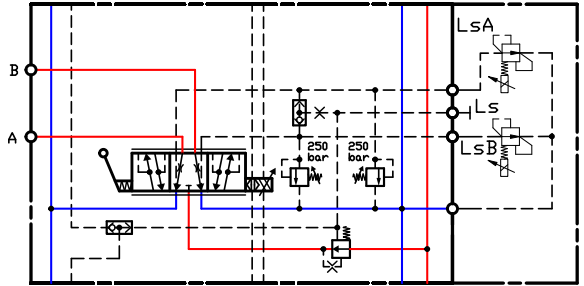

PDLD code numbers			
Hydraulic diagram	Connector type	12V dc	24V dc
<p><i>Active on LsA</i></p>	Deutsch Parallel	PDL12D11001	PDL12D31001
<p><i>Active on LsB</i></p>	Deutsch Parallel	PDL13D11001	PDL13D31001
<p><i>Active on LsA and LsB</i></p>	Deutsch Parallel	PDL11D11001	PDL11D31001
<p><i>Active on Ls</i></p>	Deutsch Parallel	PDL14D11001	PDL14D31001

PDV114 - PEAC121 Electro-hydraulic proportional actuation
Closed loop spool control, high performance resolution
Input signal control 0,5 Udc

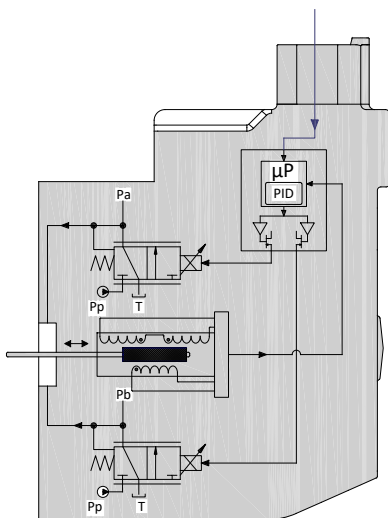
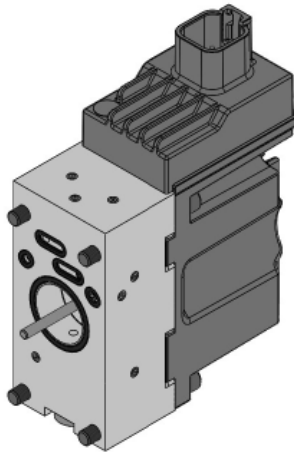

PEAC121 is a proportional high performance PDV spool actuation with integrated electronics and inductive transducer (LVDT) that operates safely and precisely the main spool movement according to an electrical signal coming from a remote control.

The input signal by means of the PCB and the two proportional pressure reducing valves, determines the level of the pilot pressure which moves the main spool.

The spool position is detected in the LVDT transducer which generates an electric feed-back signal registered by the electronics. The variation between the input signal and the feed-back signal, actuates the solenoid valves accordingly, so that, the hydraulic pilot pressure will drive the main spool in the right position.

All PEAC121 modules comes with integrated fault monitoring system, available in two version:

- Active version
- Passive version

Active fault monitoring

When an error state is detected, the two proportional solenoid valves will be automatically deactivated, a red lamp will light-up and drive the spool in neutral position (if it's not seized up). The system will only react to failures of more than 500 ms (in other words there is delay of half a second before anything happens). An alarm signal is sent out through the connector, and minus is opened.

This error state is memorized, and continues until the system is being reset by switching off the supply voltage.

Shortly, when the active fault monitoring system is connected and an error state is detected, the system ensures a fast and operator free reaction, that will put the complete hydraulic circuit into venting conditions, thus preventing uncontrollable machine movements.

Passive fault monitoring

When an error state is detected, the two proportional solenoid valves will not be deactivated, a red lamp will light-up, but still control the main spool.

When a fault condition occurs, after a delay of 250 ms an alarm signal is sent out through a devoted pin

This state is not memorized, and when the faulty state disappears, the alarm signal will turn to passive again.

In order to prevent the electronic from going into an undefined state, any time the system is being triggered or reset, a general check of power supply and the internal clock frequency is made.

The use of PEAC121 module both passive or active version, allows the machines hydraulic system to be made with different level of safety degree that for the choice of which it is essential to know the exactly required functions.

When the PEAC121 module active version is connected with the pump unloading system, the level of safety degree protection for the complete hydraulic system becomes very high, operator free, and helps OEM to meet the PL (Performance Level) required to be comply with the safety demands of Machinery Directive 2006/42/EC.

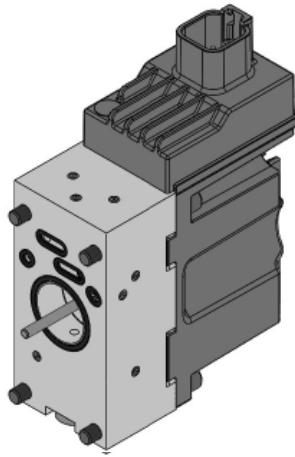

PEAC121 is defined by:

- Inductive transducer with resolution < 12 µm
- Integrated diagnosis and error memory
- Fault monitoring transistor output for signal source
- Higher spool control accuracy
- EMC performance according to Directive 2014/30/UE
- Low hysteresis
- Quicker reaction time
- Spool direction movement output
- Integrated PWM/Pulse Width Modulation
- Low electrical power

PEAC121 Technical data		
Rated supply voltage		10 ÷ 30 Vdc
Max ripple		5%
Signal control		0,5 Udc
Range control signal		0,25 Udc to 0,75 Udc
Neutral spool position		0,5 Udc
Max threshold signal, A port		1 V
Max threshold signal, B port		1 V
Max current signal @ rated voltage		48 mA
Input capacitor		100 nF
Signal control impedance		25 kΩ
Power consumption		8,7 W
Heat insulation		Class H (180°C)
Duty cycle		ED 100%
Max current consumption		650 mA
Current consumption in neutral position		80 mA
Coil impedance @ 20°C		8,9 Ω
Dither frequency		50-200 Hz
Recommended frequency		100 Hz
Enclouser degree	(Electrical wiring excepted)	IP 66 - IP 67 - IP 69K
Weight cast iron body		1,8 kg
Weight aluminium body		1,3 kg
Bootloader function, debugging parameters and set-up function available only with Deutsch connector DT06-6S		
Fault monitoring system	Max current on safety output (pin 5)	50 mA
	Reaction time a fault	500 ms
Max current output signal for spool direction movment		50 mA
Reaction time (constant voltage)	From neutral position to max spool travel	110 - 140 ms
	From max spool travel to neutral	70 - 90 ms
Reaction time (neutral switch)	From neutral position to max spool travel	130 - 170 ms
	From max spool travel to neutral	70 - 90 ms

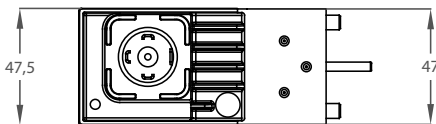
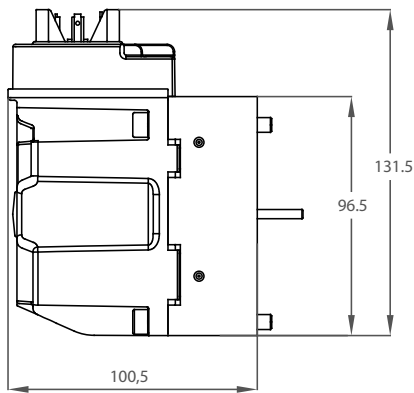
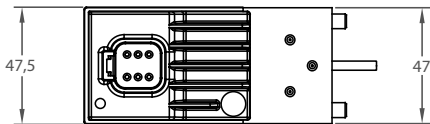
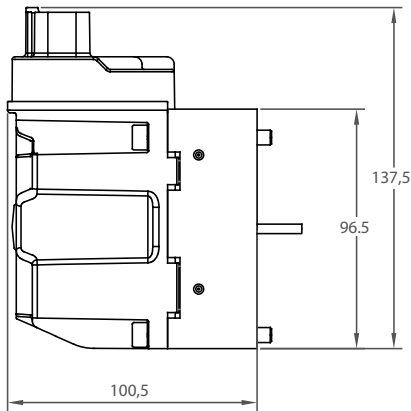

Deutsch connector DT06-6S Enclosure degree IP 69K PIN-assignment			
	1	Power supply	
	2	Input signal control	
	3	CAN-high	A port-spool movement signal
	4	CAN-low	B port-spool movement signal
	5	Fault monitoring signal	
	6	Ground	

Hirschmann connector DIN 43650 Enclosure degree IP 65 PIN-assignment			
	1	Power supply	
	2	Input signal control	
	3	Fault monitoring signal	
	4	Ground	

Connector version	Code numbers			
	Active version		Passive version	
	Cast-iron body	Aluminium body	Cast-iron body	Aluminium body
Deutsch DT06-6S	PEAC0141000	PEAC1141000	PEAC0131000	PEAC1131000
DIN 43650	PEAC0141200	PEAC1141200	PEAC0131200	PEAC1131200

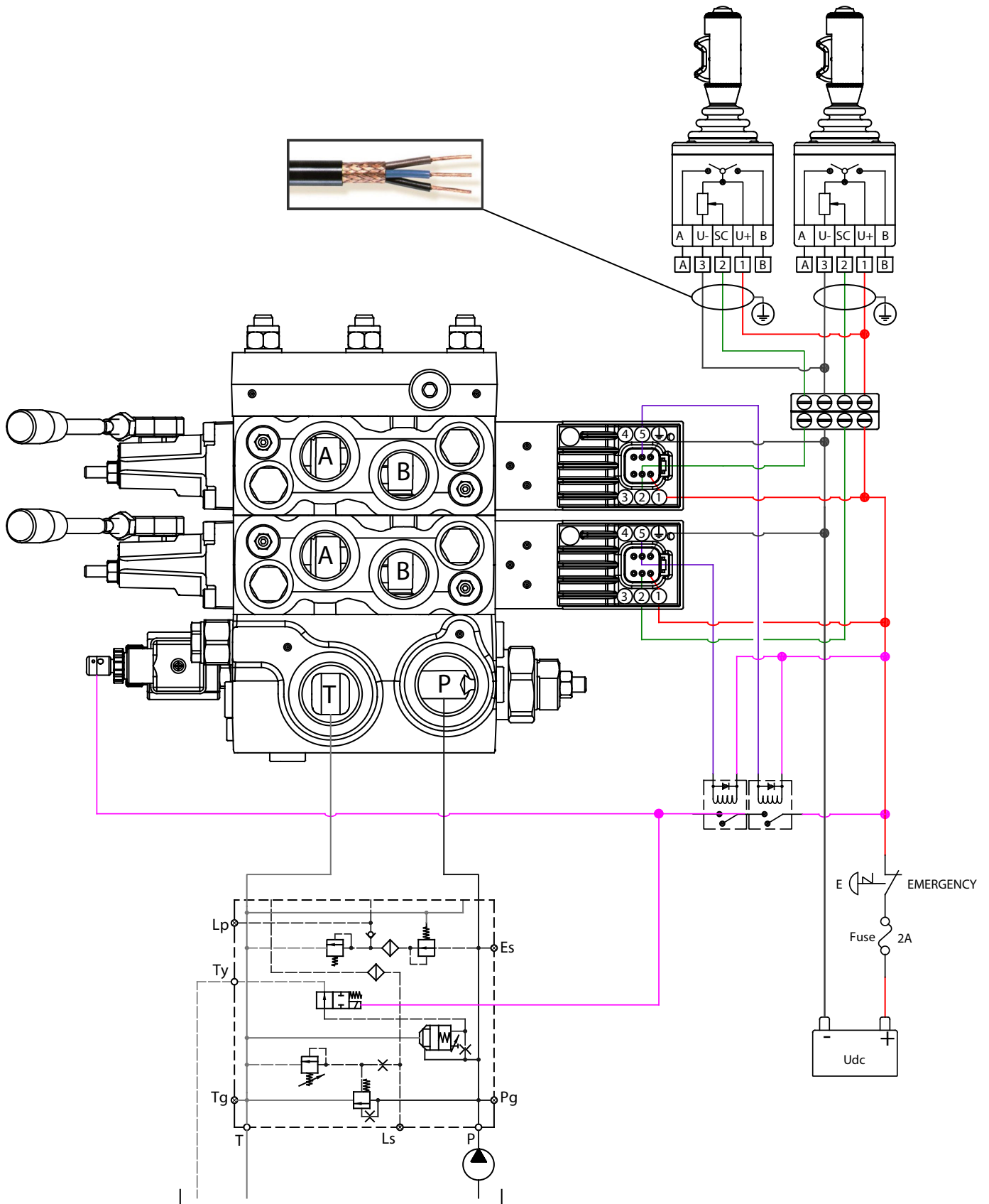

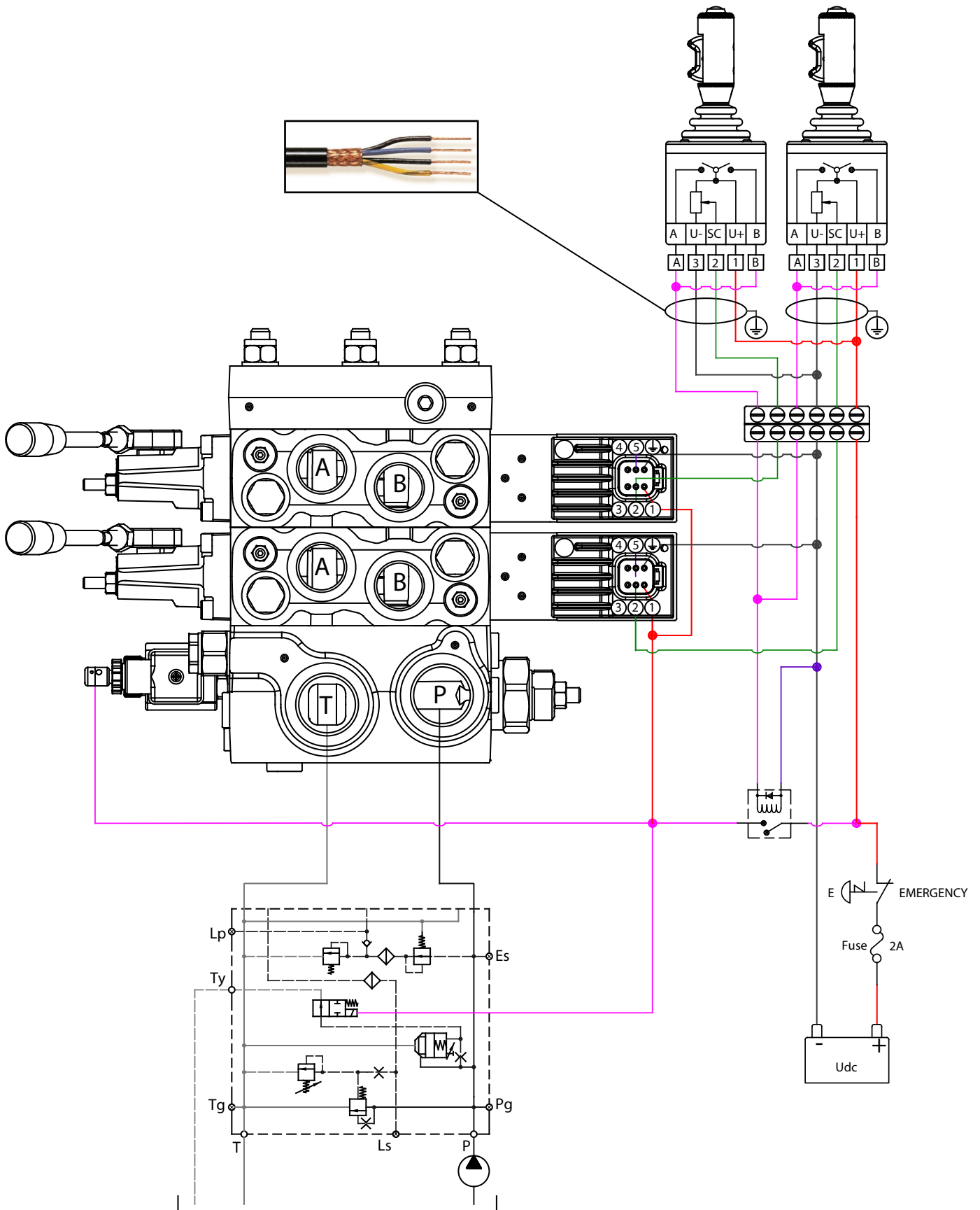

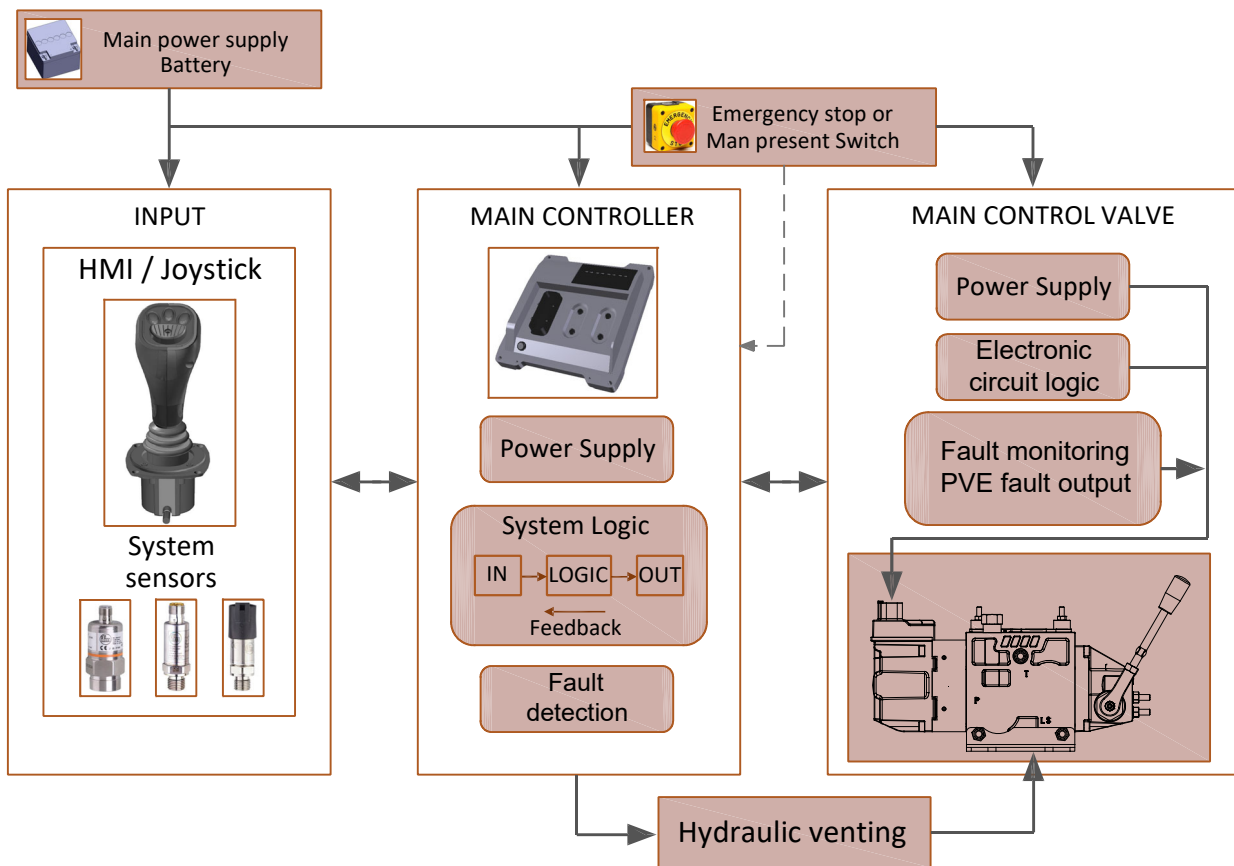

PDV114 - PEAC121 Electro-hydraulic proportional actuation
Electrical wiring diagram with OMFB I/O controller
 Input signal 0,5 Udc

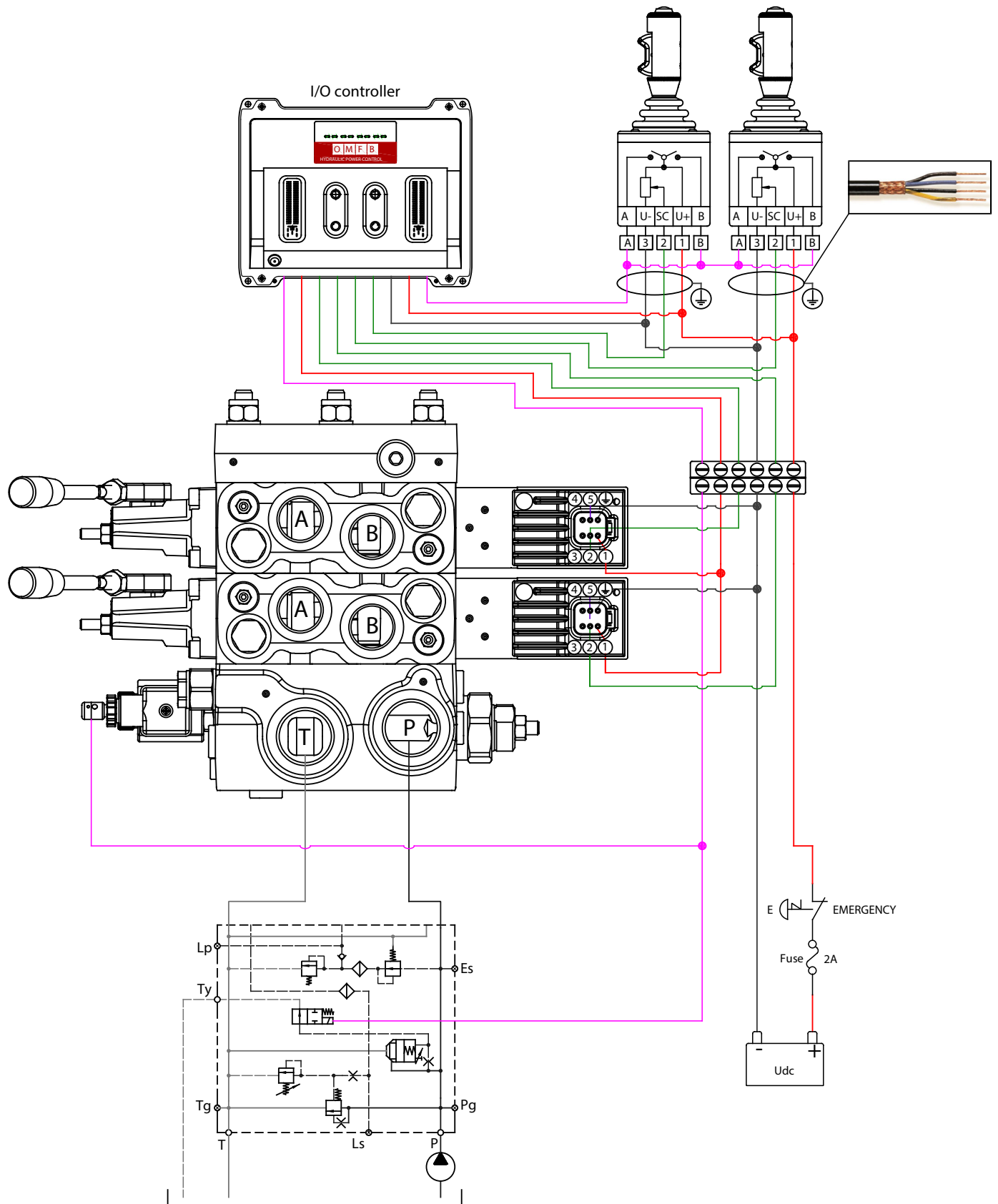

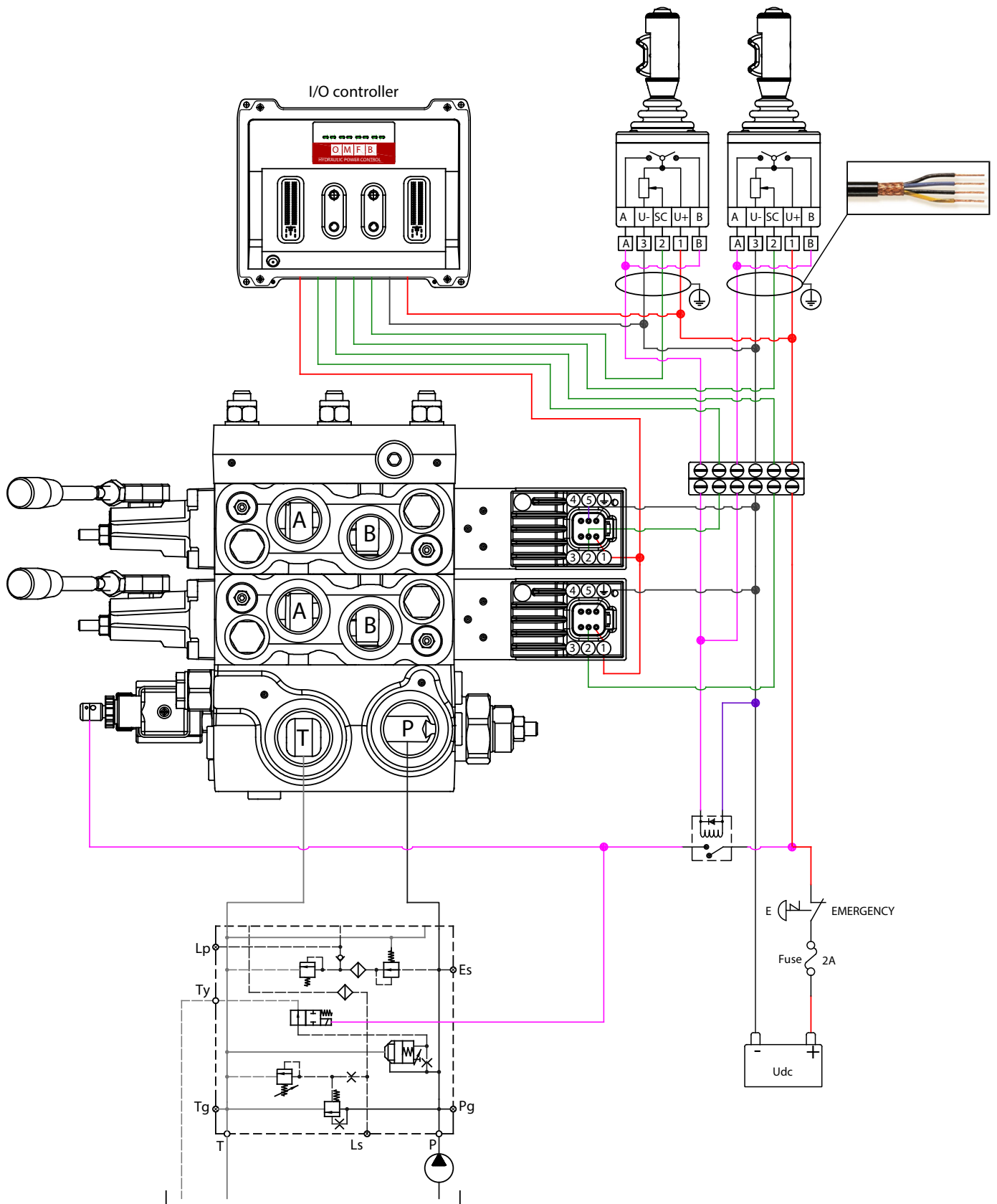

PDV114 - PEAC122 Electro-hydraulic proportional actuation
Closed loop spool control, high performance resolution
Input signal control 0 ÷ 10 V

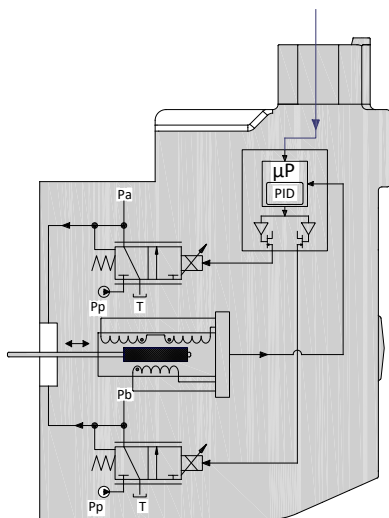
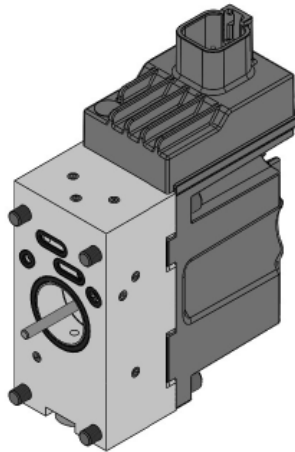

PEAC122 is a proportional high performance PDV spool actuation with integrated electronics and inductive transducer (LVDT) that operates safely and precisely the main spool movement according to an electrical signal coming from a remote control.

The input signal by means of the PCB and the two proportional pressure reducing valves, determines the level of the pilot pressure which moves the main spool.

The spool position is detected in the LVDT transducer which generates an electric feed-back signal registered by the electronics. The variation between the input signal and the feed-back signal, actuates the solenoid valves accordingly, so that, the hydraulic pilot pressure will drive the main spool in the right position.

All PEAC122 modules comes with integrated fault monitoring system, available in two version:

- Active version
- Passive version

Active fault monitoring

When an error state is detected, the two proportional solenoid valves will be automatically deactivated, a red lamp will light-up and drive the spool in neutral position (if it's not seized up). The system will only react to failures of more than 500 ms (in other words there is delay of half a second before anything happens). An alarm signal is sent out through the connector, and minus is opened.

This error state is memorized, and continues until the system is being reset by switching off the supply voltage.

Shortly, when the active fault monitoring system is connected and an error state is detected, the system ensures a fast and operator free reaction, that will put the complete hydraulic circuit into venting conditions, thus preventing uncontrollable machine movements.

Passive fault monitoring

When an error state is detected, the two proportional solenoid valves will not be deactivated, a red lamp will light-up, but still control the main spool.

When a fault condition occurs, after a delay of 250 ms an alarm signal is sent out through a devoted pin

This state is not memorized, and when the faulty state disappears, the alarm signal will turn to passive again.

In order to prevent the electronic from going into an undefined state, any time the system is being triggered or reset, a general check of power supply and the internal clock frequency is made.

The use of PEAC122 module both passive or active version, allows the machines hydraulic system to be made with different level of safety degree that for the choice of which it is essential to know the exactly required functions.

When the PEAC122 module active version is connected with the pump unloading system, the level of safety degree protection for the complete hydraulic system becomes very high, operator free, and helps OEM to meet the PL (Performance Level) required to be comply with the safety demands of Machinery Directive 2006/42/EC.

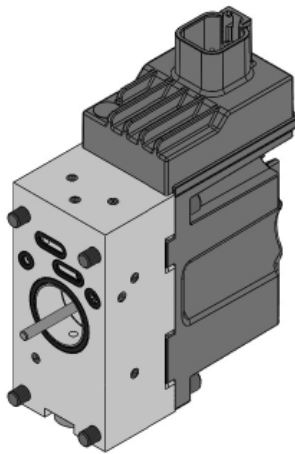

PEAC122 is defined by:

- Inductive transducer with resolution < 12 µm
- Integrated diagnosis and error memory
- Fault monitoring transistor output for signal source
- Higher spool control accuracy
- EMC performance to
- Low hysteresis
- Quicker reaction time
- Spool direction movement output
- Integrated PWM/Pulse Width Modulation
- Low electrical power

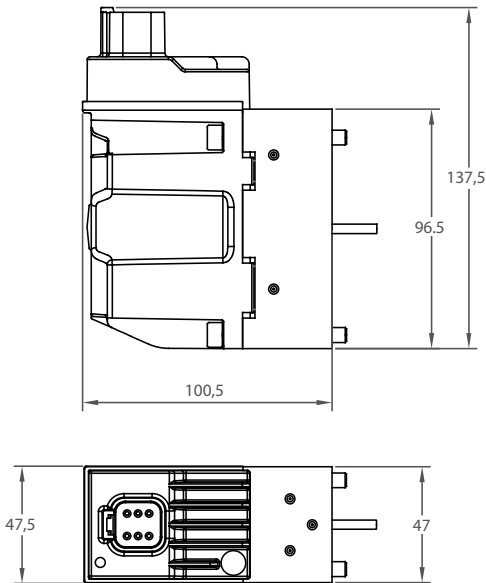
PEAC122 Technical data		
Rated supply voltage		10-30 Vdc
Max ripple		5%
Signal control		0-10 V
Range control signal		2,5 V to 7,5 V
Neutral spool position		5 V
Max threshold signal, A port		1 V
Max threshold signal, B port		1 V
Max current signal @ rated voltage		48 mA
Input capacitor		100 nF
Signal control impedance		25 kΩ
Power consumption		8,7 W
Heat insulation		Class H (180°C)
Duty cycle		ED 100%
Max current consumption		650 mA
Current consumption in neutral position		80 mA
Coil impedance @ 20°C		8,9 Ω
Dither frequency		50-200 Hz
Recommended frequency		100 Hz
Enclouser degree	(Electrical wiring excepted)	IP 66 - IP 67 - IP 69K
Weight cast iron body		1,8 kg
Weight aluminium body		1,3 kg
Bootloader function, debugging parameters and set-up function available only with Deutsch connector DT06-6S		
Fault monitoring system	Max current on safety output (pin 5)	50 mA
	Reaction time a fault	500 ms
Max current output signal for spool direction movement		50 mA
Reaction time (constant voltage)	From neutral position to max spool travel	110 - 140 ms
	From max spool travel to neutral	70 - 90 ms
Reaction time (neutral switch)	From neutral position to max spool travel	130 - 170 ms
	From max spool travel to neutral	70 - 90 ms

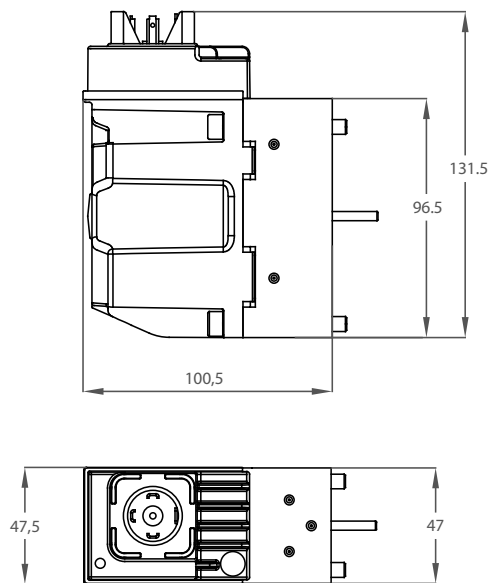

Deutsch connector DT06-6S Enclosure degree IP 69K PIN-assignment			
	1	Power supply	
	2	Input signal control	
	3	CAN-high	A port-spool movement signal
	4	CAN-low	B port-spool movement signal
	5	Fault monitoring signal	
	6	Ground	



Hirschmann connector DIN 43650 Enclosure degree IP 65 PIN-assignment			
	1	Power supply	
	2	Input signal control	
	3	Fault monitoring signal	
	4	Ground	

Connector version	Code numbers			
	Active version		Passive version	
	Cast-iron body	Aluminium body	Cast-iron body	Aluminium body
Deutsch DT06-6S	PEAC0142000	PEAC1142000	PEAC0132000	PEAC1132000
DIN 43650	PEAC0142200	PEAC1142200	PEAC0132200	PEAC1132200

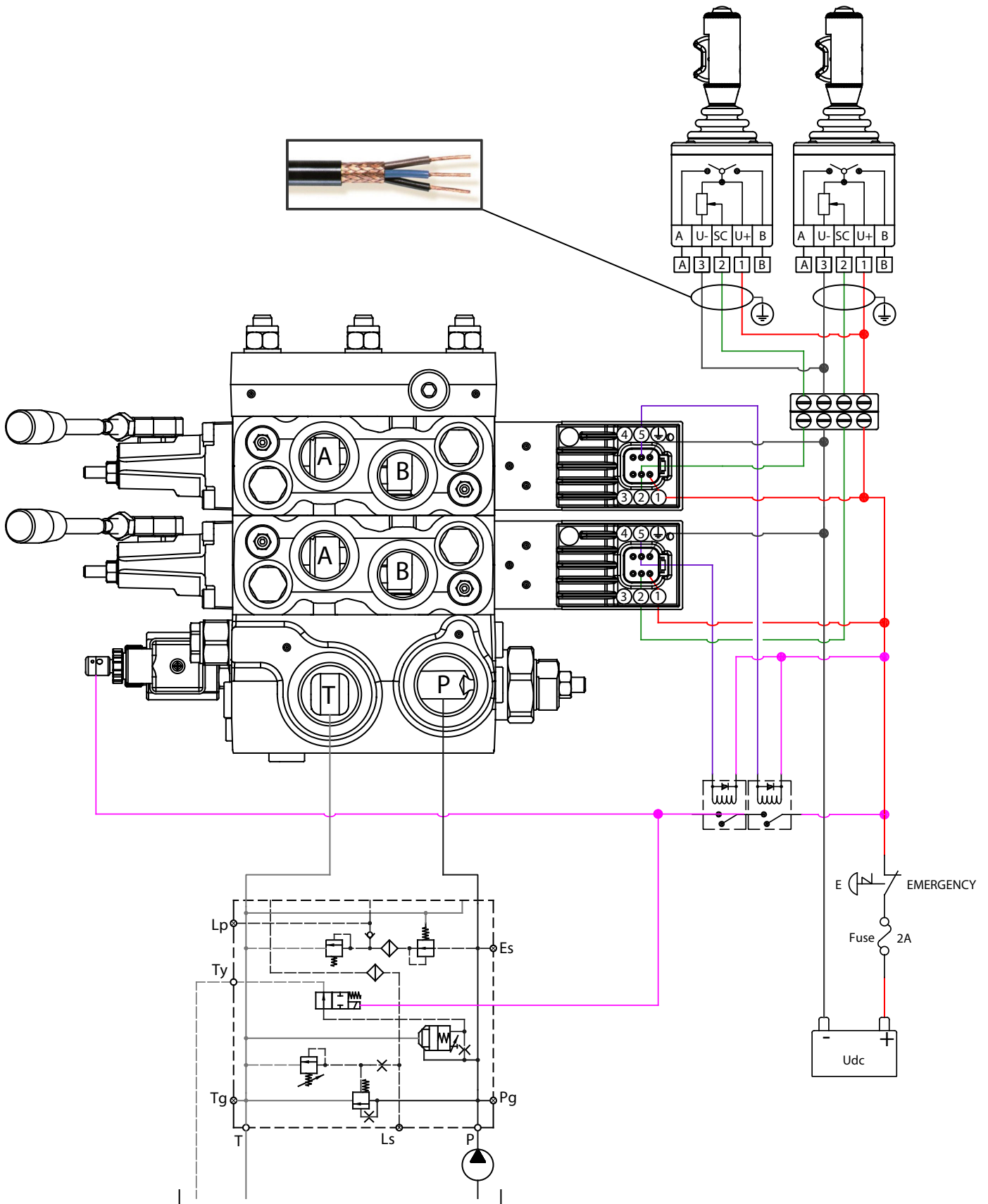

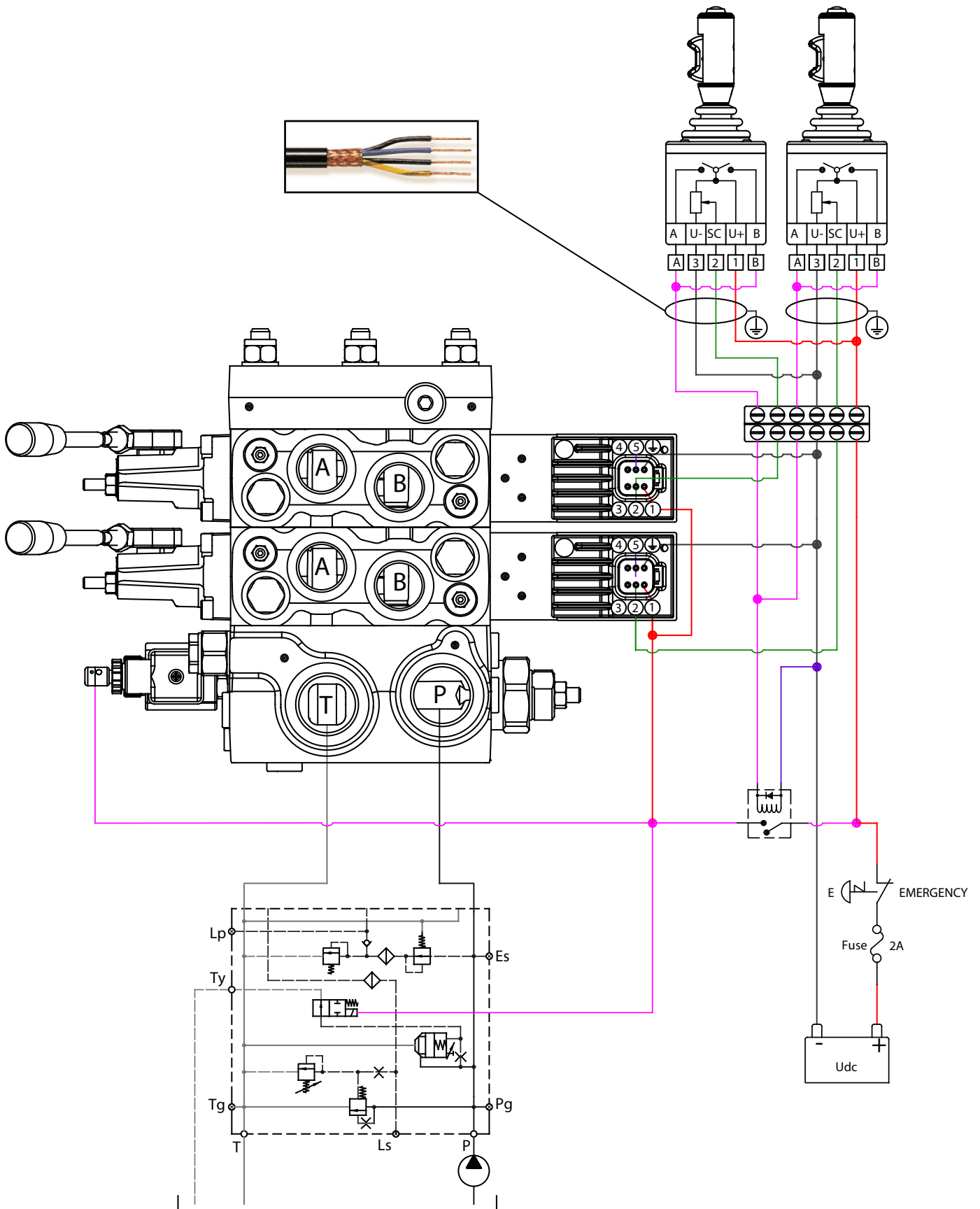

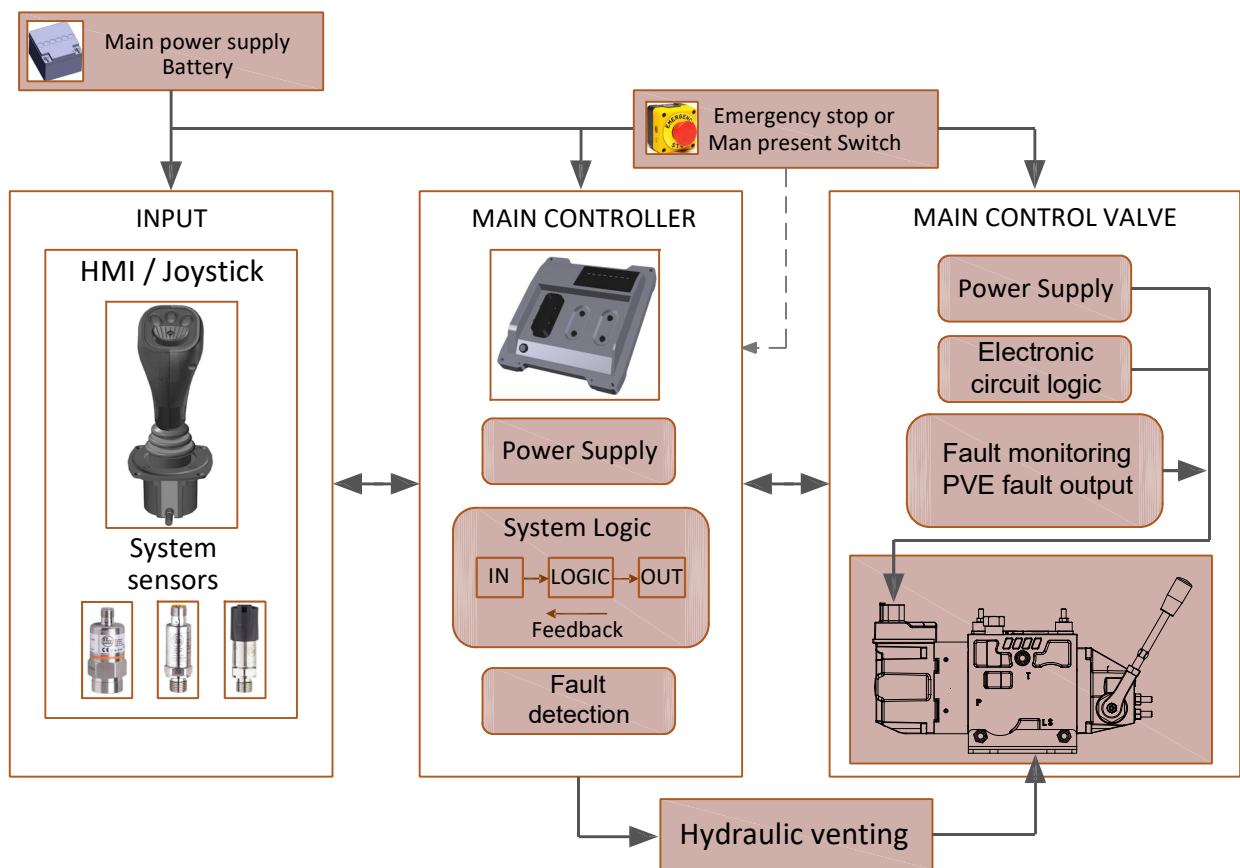

PDV114 - PEAC122 Electro-hydraulic proportional actuation
Electrical wiring diagram with OMFB I/O controller
Input signal 0 ÷ 10 V

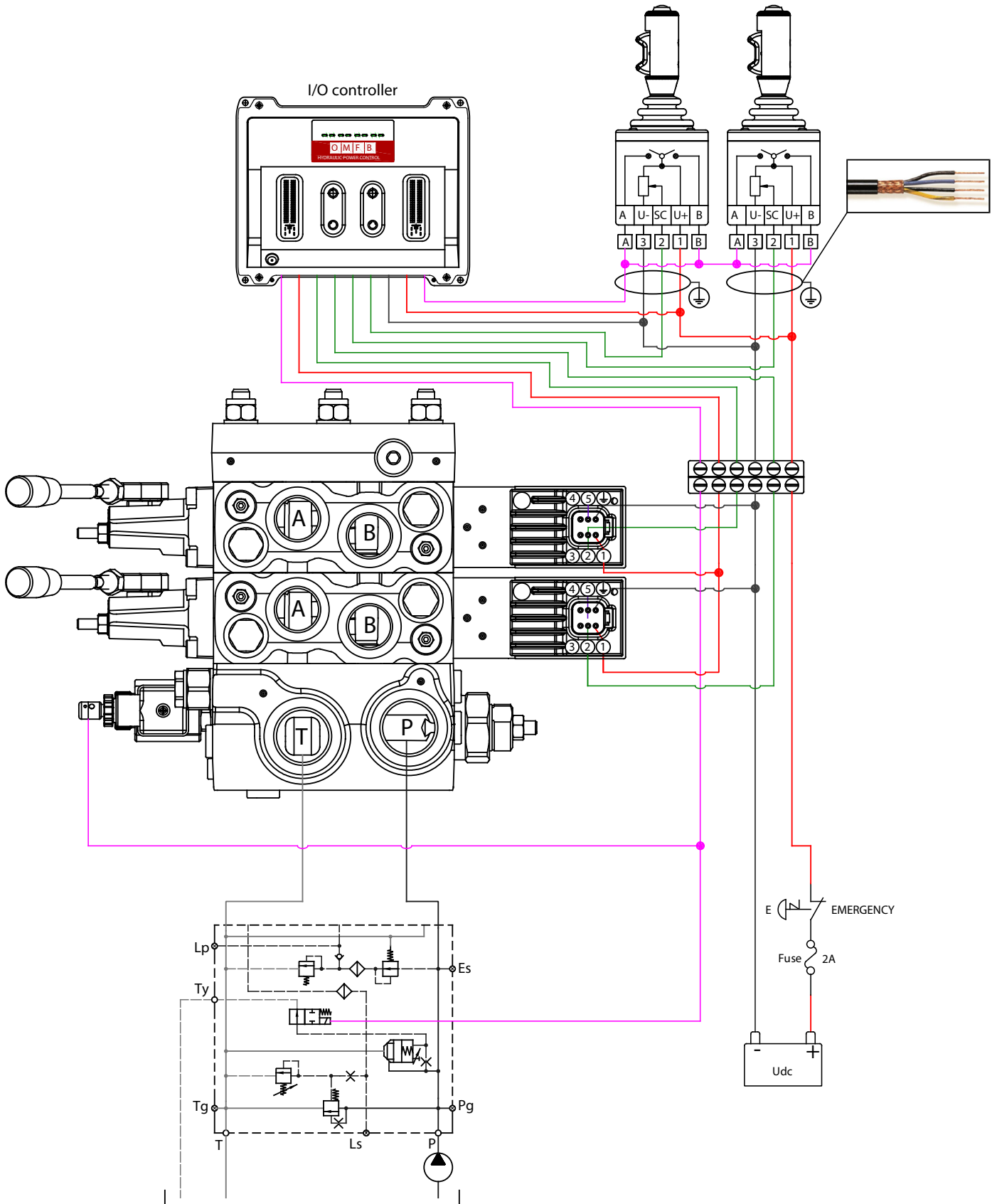

PDV114 - PEAC122 Electro-hydraulic proportional actuation
Electrical wiring diagram with OMFB I/O controller
Input signal 0 ÷ 10 V

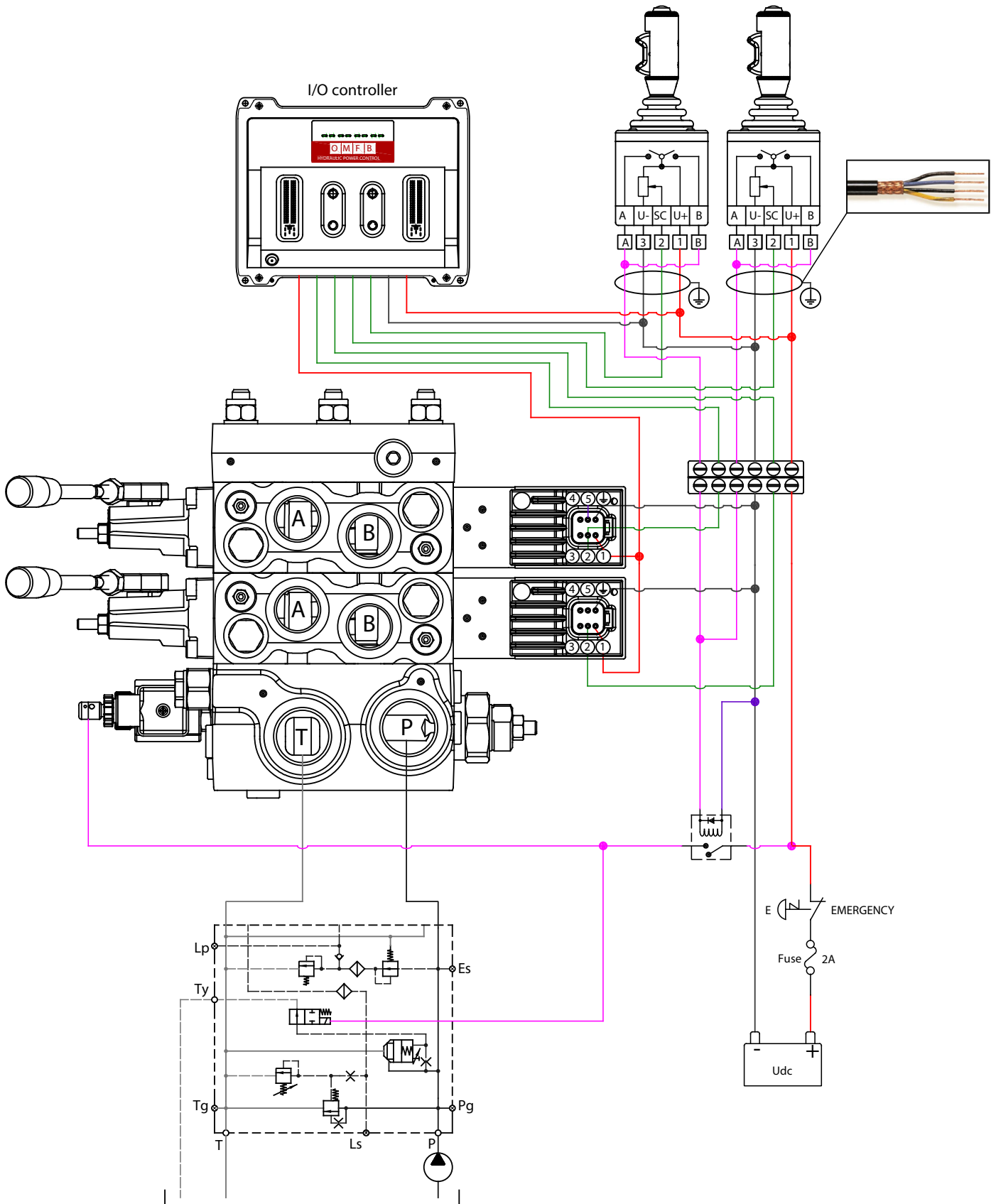

PDV114 - PEAC126 Electro-hydraulic proportional actuation
Closed loop spool control, high performance resolution
Input signal 4 ÷ 20 mA

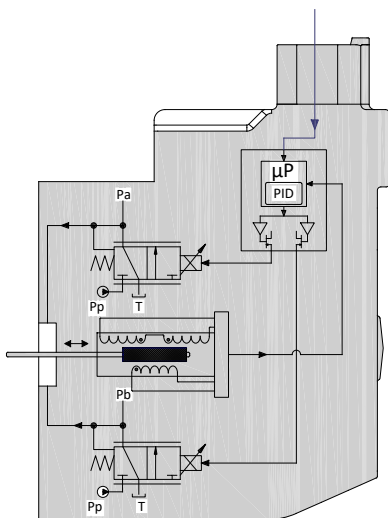
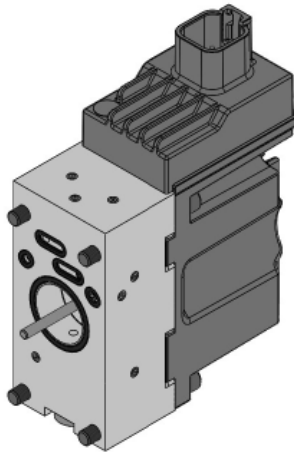

PEAC126 is a proportional high performance PDV spool actuation with integrated electronics and inductive transducer (LVDT) that operates safely and precisely the main spool movement according to an electrical signal coming from a remote control.

The input signal by means of the PCB and the two proportional pressure reducing valves, determines the level of the pilot pressure which moves the main spool.

The spool position is detected in the LVDT transducer which generates an electric feed-back signal registered by the electronics.

The variation between the input signal and the feed-back signal, actuates the solenoid valves accordingly, so that, the hydraulic pilot pressure will drive the main spool in the right position.

All PEAC126 modules comes with integrated fault monitoring system, available in two version:

- Active version
- Passive version

Active fault monitoring

When an error state is detected, the two proportional solenoid valves will be automatically deactivated, a red lamp will light-up and drive the spool in neutral position (if it's not seized up). The system will only react to failures of more than 500 ms (in other words there is delay of half a second before anything happens). An alarm signal is sent out through the connector, and minus is opened.

This error state is memorized, and continues until the system is being reset by switching off the supply voltage.

Shortly, when the active fault monitoring system is connected and an error state is detected, the system ensures a fast and operator free reaction, that will put the complete hydraulic circuit into venting conditions, thus preventing uncontrollable machine movements.

Passive fault monitoring

When an error state is detected, the two proportional solenoid valves will not be deactivated, a red lamp will light-up, but still control the main spool.

When a fault condition occurs, after a delay of 250 ms an alarm signal is sent out through a devoted pin

This state is not memorized, and when the faulty state disappears, the alarm signal will turn to passive again.

In order to prevent the electronic from going into an undefined state, any time the system is being triggered or reset, a general check of power supply and the internal clock frequency is made.

The use of PEAC126 module both passive or active version, allows the machines hydraulic system to be made with different level of safety degree that for the choice of which it is essential to know the exactly required functions.

When the PEAC126 module active version is connected with the pump unloading system, the level of safety degree protection for the complete hydraulic system becomes very high, operator free, and helps OEM to meet the PL (Performance Level) required to be comply with the safety demands of Machinery Directive 2006/42/EC.

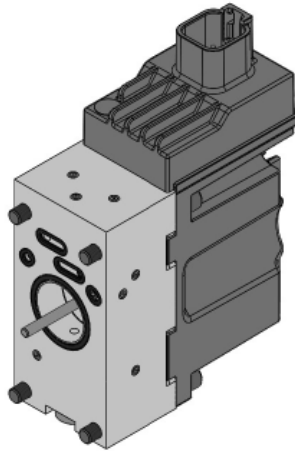

PEAC126 is defined by:

- Inductive transducer with resolution < 12 µm
- Integrated diagnosis and error memory
- Fault monitoring transistor output for signal source
- Higher spool control accuracy
- EMC performance according to Directive 2014/30/UE
- Low hysteresis
- Quicker reaction time
- Spool direction movement output
- Integrated PWM/Pulse Width Modulation
- Low electrical power
- Robust and reliable design

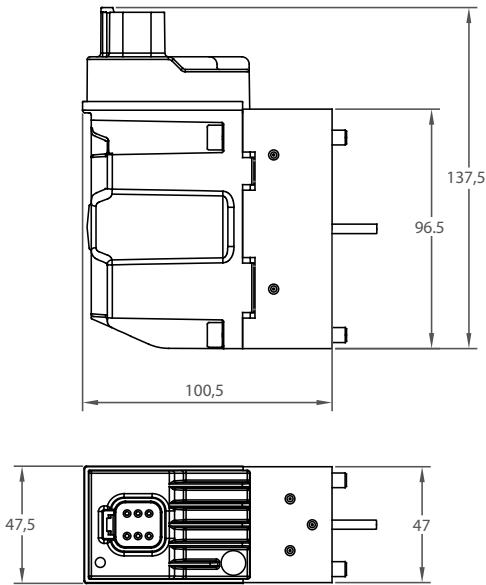
PEAC126 Technical data		
Rated supply voltage	10 ÷ 30 Vdc	
Max ripple	5%	
Signal control	4 ÷ 20 mA	
Range control signal	4 mA to 20 mA	
Neutral spool position	12 mA	
Max threshold signal, A port	1,5 mA	
Max threshold signal, B port	1,5 mA	
Max current signal @ rated voltage	48 mA	
Input capacitor	100 nF	
Signal control impedance	220 Ω	
Power consumption	8,7 W	
Heat insulation	Class H (180°C)	
Duty cycle	ED 100%	
Max current consumption	650 mA	
Current consumption in neutral position	80 mA	
Coil impedance @ 20°C	8,9 Ω	
Dither frequency	50 ÷ 200 Hz	
Recommended frequency	100 Hz	
Enclouser degree	(Electrical wiring excepted) IP65 - IP66 - IP69K	
Weight cast iron body	1,8 kg	
Weight aluminium body	1,3 kg	
Bootloader function, debugging parameters and set-up function available with Deutsch connector DT06-6S, only		
Fault monitoring system	Max current on safety output (pin 5)	50 mA
	Reaction time a fault	500 ms
Max current output signal for spool direction moviment		50 mA
Reaction time (constant voltage)	From neutral position to max spool travel	110 ÷ 140 ms
	From max spool travel to neutral	70 ÷ 90 ms
Reaction time (neutral switch)	From neutral position to max spool travel	130 ÷ 170 ms
	From max spool travel to neutral	70 ÷ 90 ms

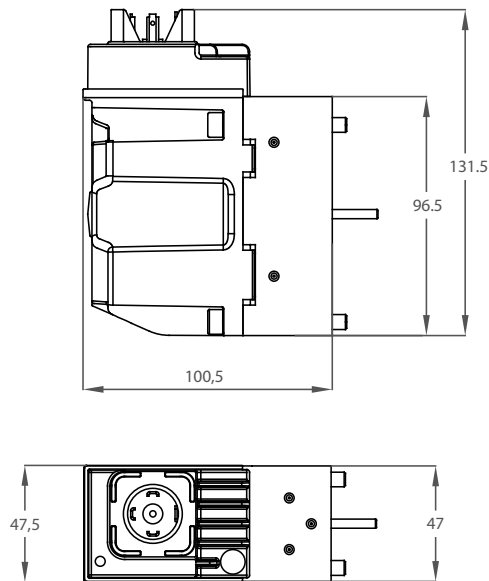

Deutsch connector DT06-6S Enclosure degree IP 69K PIN-assignment			
	1	Power supply	
	2	Input signal control	
	3	CAN-high	A port-spool movement signal
	4	CAN-low	B port-spool movement signal
	5	Fault monitoring signal	
	6	Ground	



Hirschmann connector DIN 43650 Enclosure degree IP 65 PIN-assignment			
	1	Power supply	
	2	Input signal control	
	3	Fault monitoring signal	
	4	Ground	

Connector version	Code numbers			
	Active version		Passive version	
	Cast-iron body	Aluminium body	Cast-iron body	Aluminium body
Deutsch DT06-6S	PEAC0146000	PEAC1146000	PEAC0136000	PEAC1136000
DIN 43650	PEAC0146200	PEAC1146200	PEAC0136200	PEAC1136200

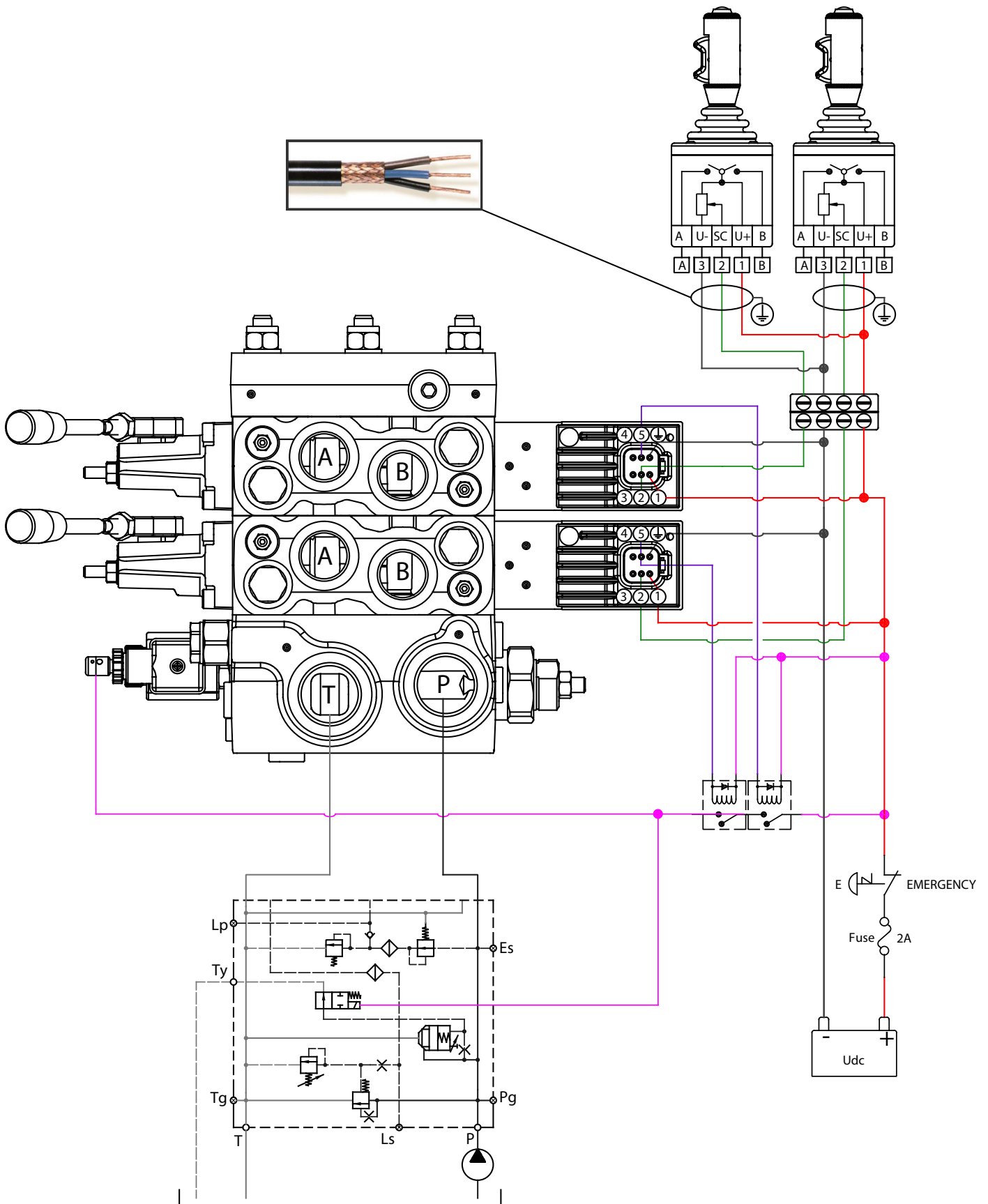

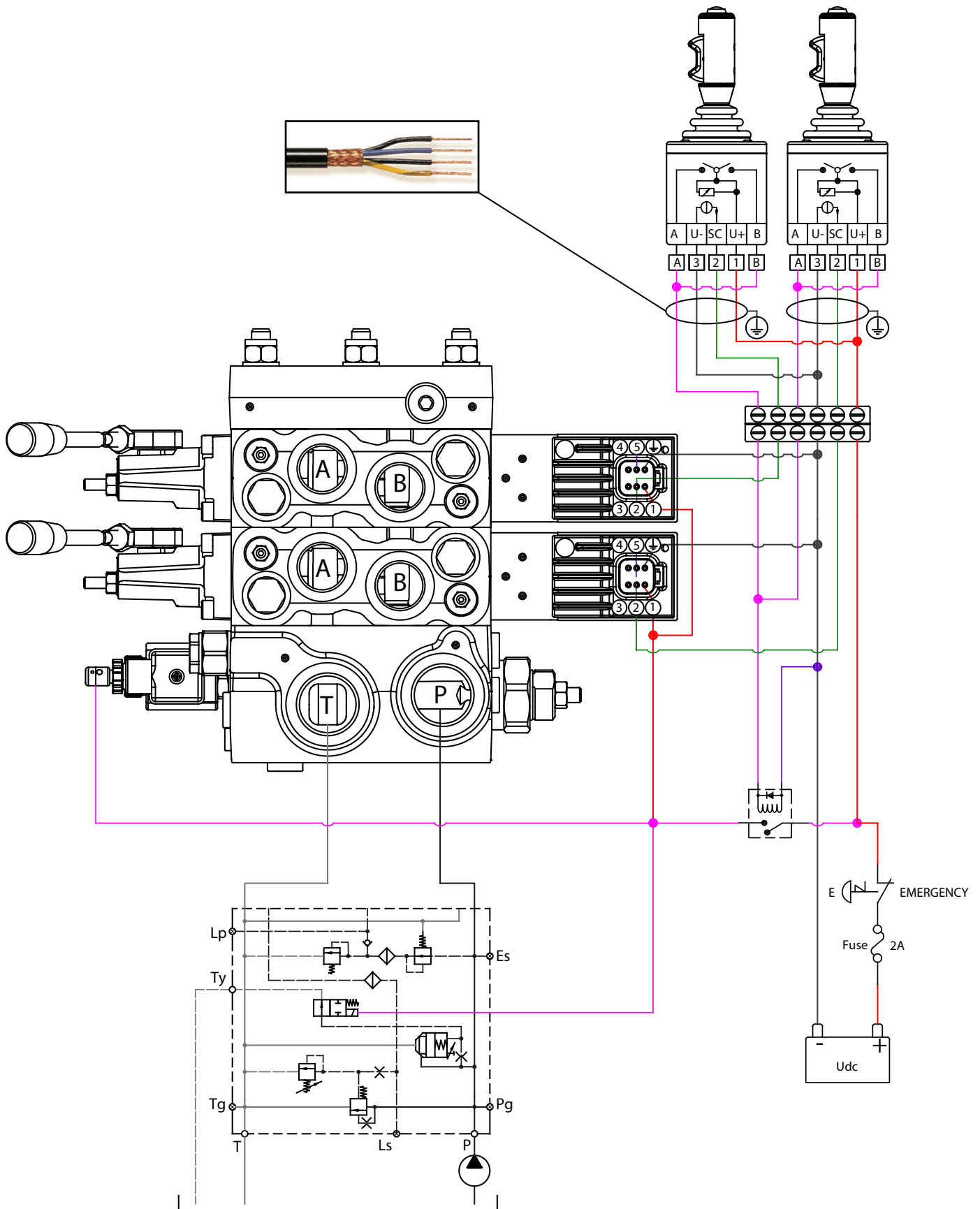

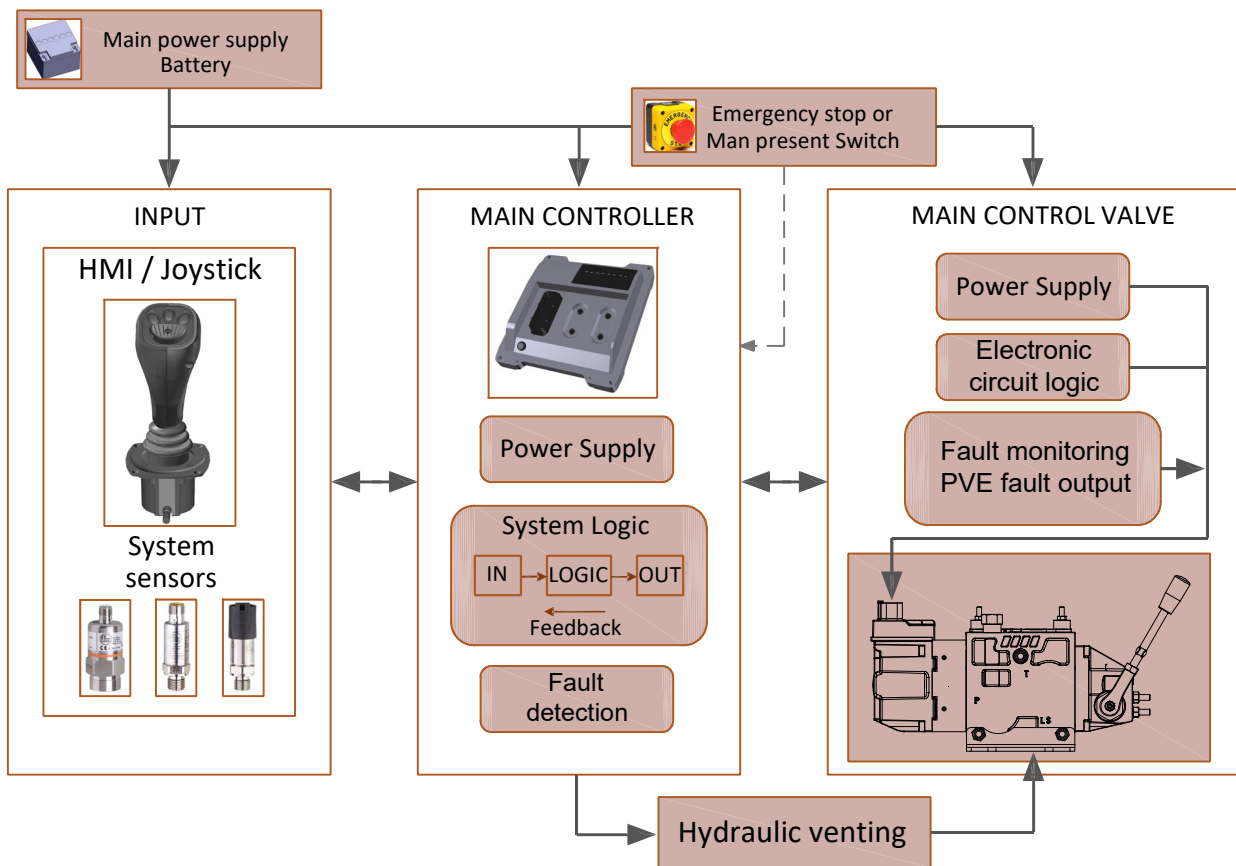

PDV114 - PEAC126 Electro-hydraulic proportional actuation.
Electrical wiring with OMFB I/O controller
Input signal 4 ÷ 20 mA

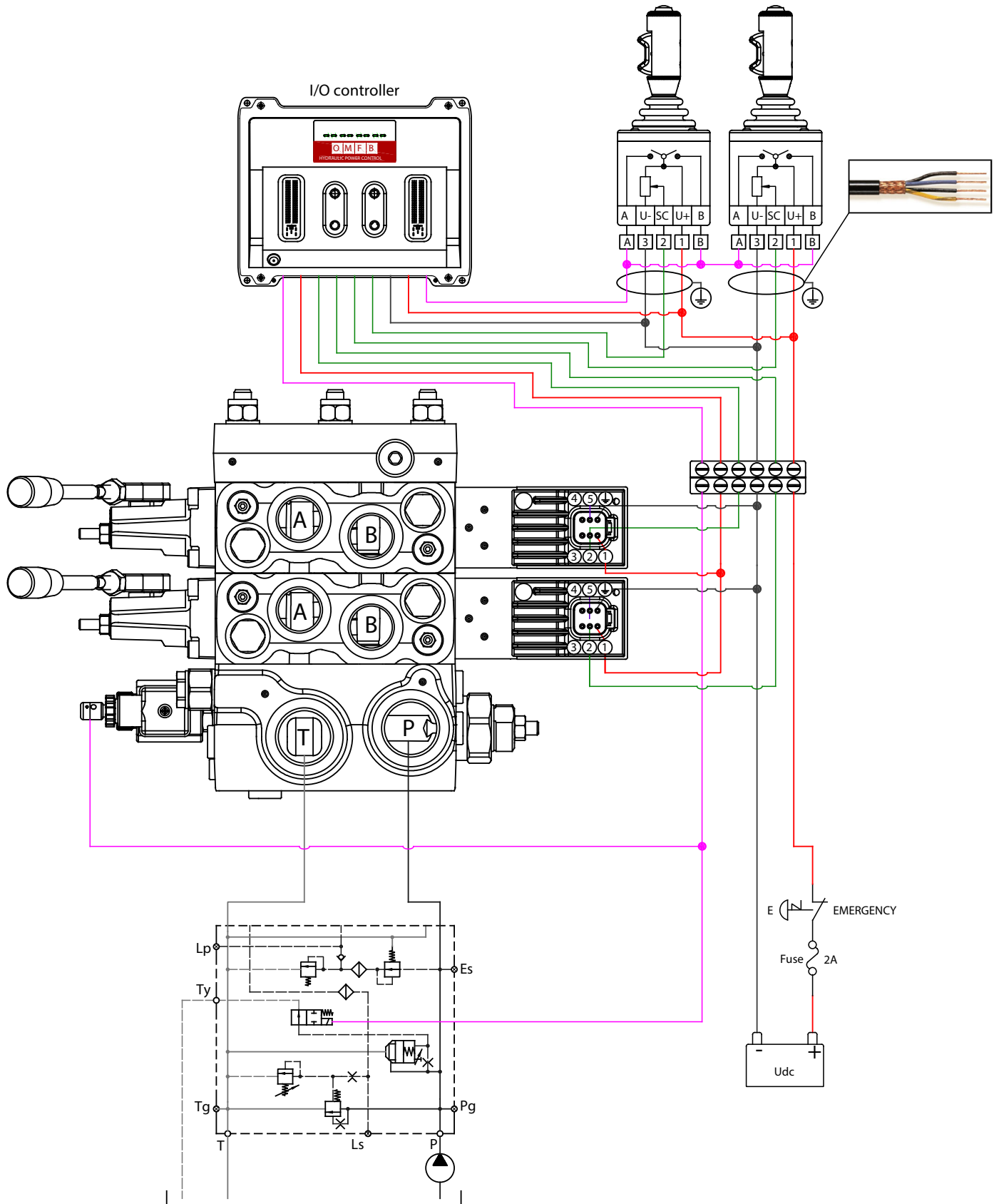

PDV114 - PEAC126 Electro-hydraulic proportional actuation
Electrical wiring diagram with OMFB I/O controller
Input signal 4 ÷ 20 mA

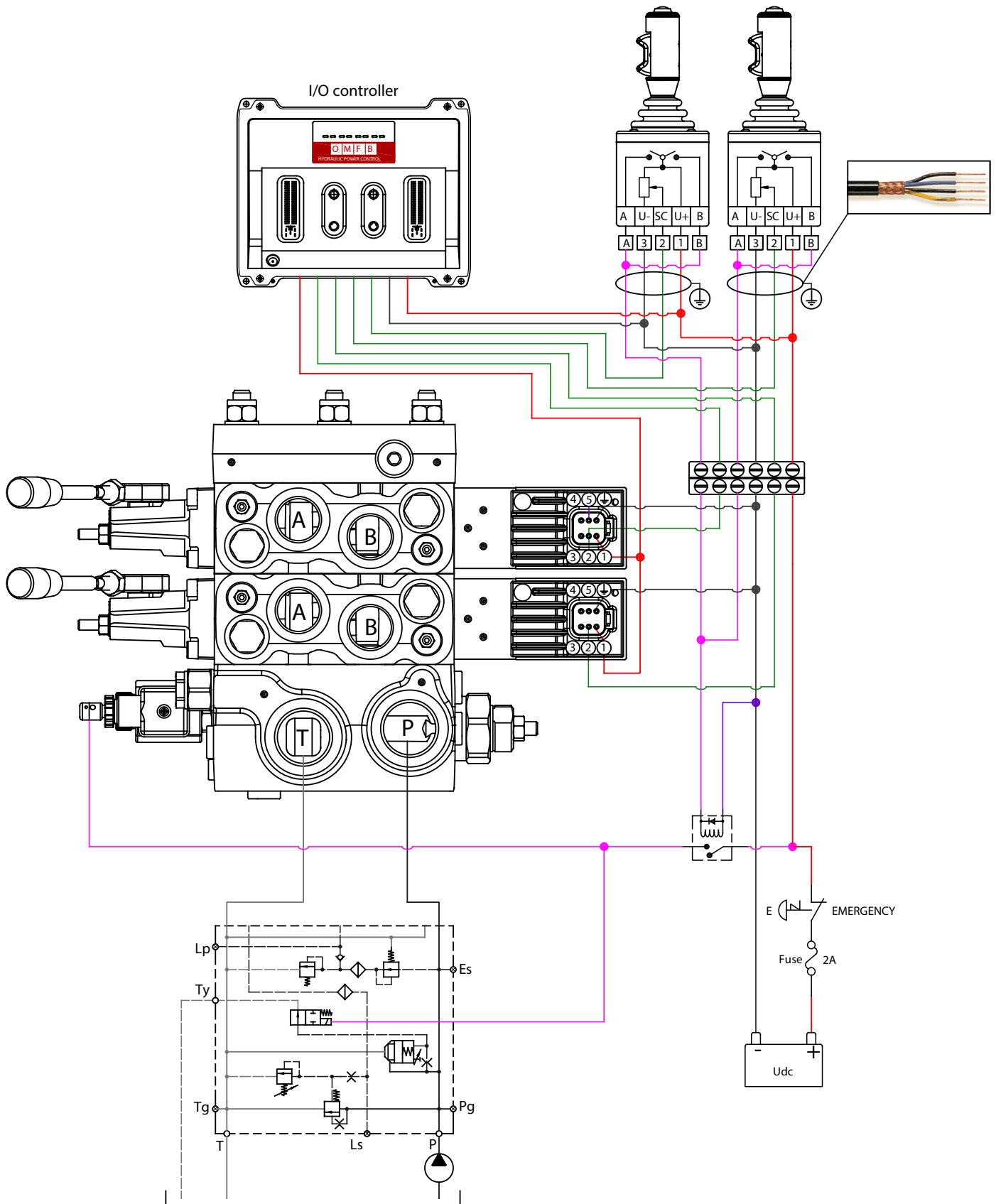

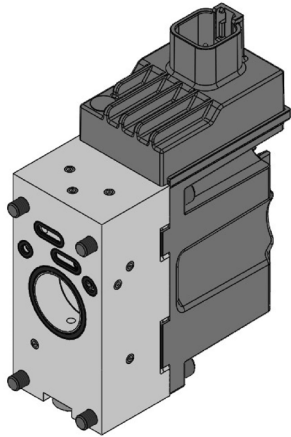

PEAC021 is a proportional open loop spool actuation with integrated electronics that operates the main spool movement according to an electrical signal coming from a remote control.

The input signal by means of the PCB and the two proportional pressure reducing valves, determines the level of the pilot pressure which moves the main spool.

PEAC021 does not have neither the transducer spool position control nor fault monitoring system, this means that any forces which override the pilot pressure spool forces, may change the spool position with no error signal, and the safety of the whole system is left to the operator's visual control, only.

PEAC021 is recommended where a simple proportional control is required, and where hysteresis and reaction time are not so critical.

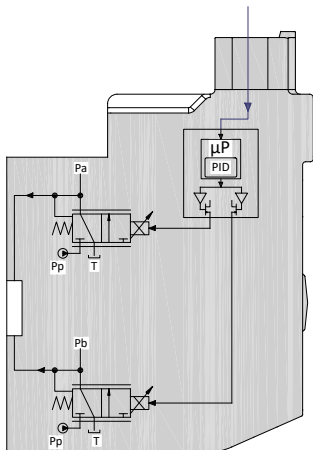

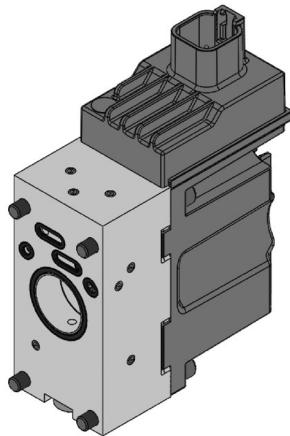

PEAC021 is defined by:

- High spool control accuracy
- EMC performace according to Directive 2014/30/UE
- Quick reaction time
- Integrated PWM/Pulse Width Modulation
- Low electrical power
- Robust and reliable design

PEAC021 Technical data		
Rated supply voltage	10-30 Vdc	
Max ripple	5%	
Signal control	0,5 Udc	
Range control signal	0,25 Udc to 0,75 Udc	
Neutral spool position	0,5 Udc	
Max threshold signal, A port	1 V	
Max threshold signal, B port	1 V	
Max current signal @ rated voltage	48 mA	
Input capacitor	100 nF	
Signal control impedance	25 kΩ	
Power consumption	8,7 W	
Heat insulation	Class H (180°C)	
Duty cycle	ED 100%	
Max current consumption	650 mA	
Current consumption in neutral position	80 mA	
Coil impedance @ 20°C	8,9 Ω	
Dither frequency	50-200 Hz	
Recommended frequency	100 Hz	
Enclouser degree	(Electrical wiring excepted)	
	IP 66 - IP 67 - IP 69K	
Weight cast iron body	1,8 kg	
Weight aluminium body	1,3 kg	
Bootloader function, debugging parameters and set-up function available only with Deutsch connector DT06-6S		
Reaction time (constant voltage)	From neutral position to max spool travel	110 - 140 ms
	From max spool travel to neutral	70 - 90 ms
Reaction time (neutral switch)	From neutral position to max spool travel	130 - 170 ms
	From max spool travel to neutral	70 - 90 ms

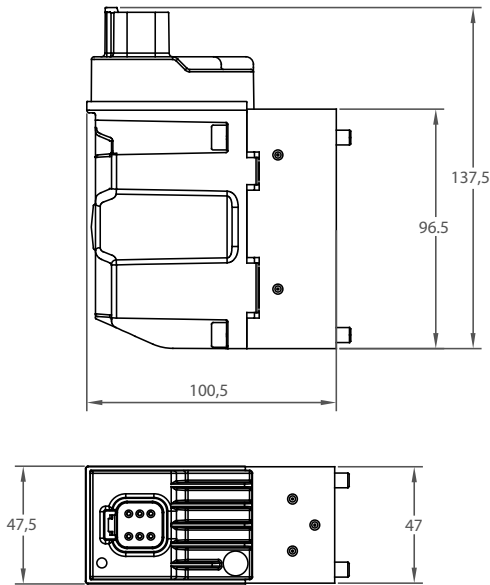

Deutsch connector DT06-6S Enclosure degree IP 69K PIN-assignment		
	1	Power supply
	2	Input signal control
	3	CAN-high
	4	CAN-low
	5	Free
	6	Ground

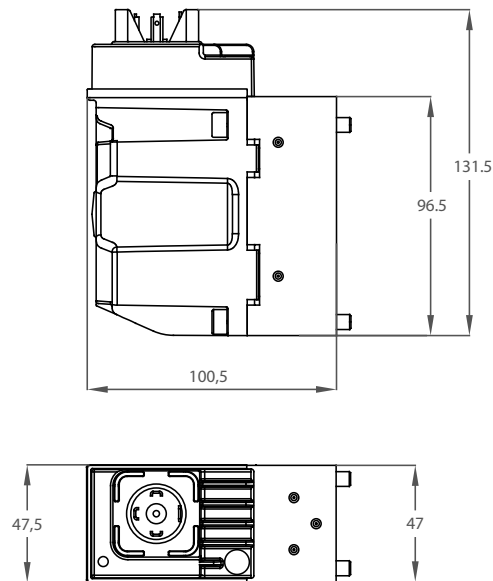

Hirschmann connector DIN 43650 Enclosure degree IP 65 PIN-assignment		
	1	Power supply
	2	Input signal control
	3	Free
	4	Ground

Connector version	Code numbers			
	Active version		Passive version	
	Cast-iron body	Aluminium body	Cast-iron body	Aluminium body
Deutsch DT06-6S	PEAC0041000	PEAC1041000	PEAC0031000	PEAC1031000
DIN 43650	PEAC0041200	PEAC1041200	PEAC0031200	PEAC1031200

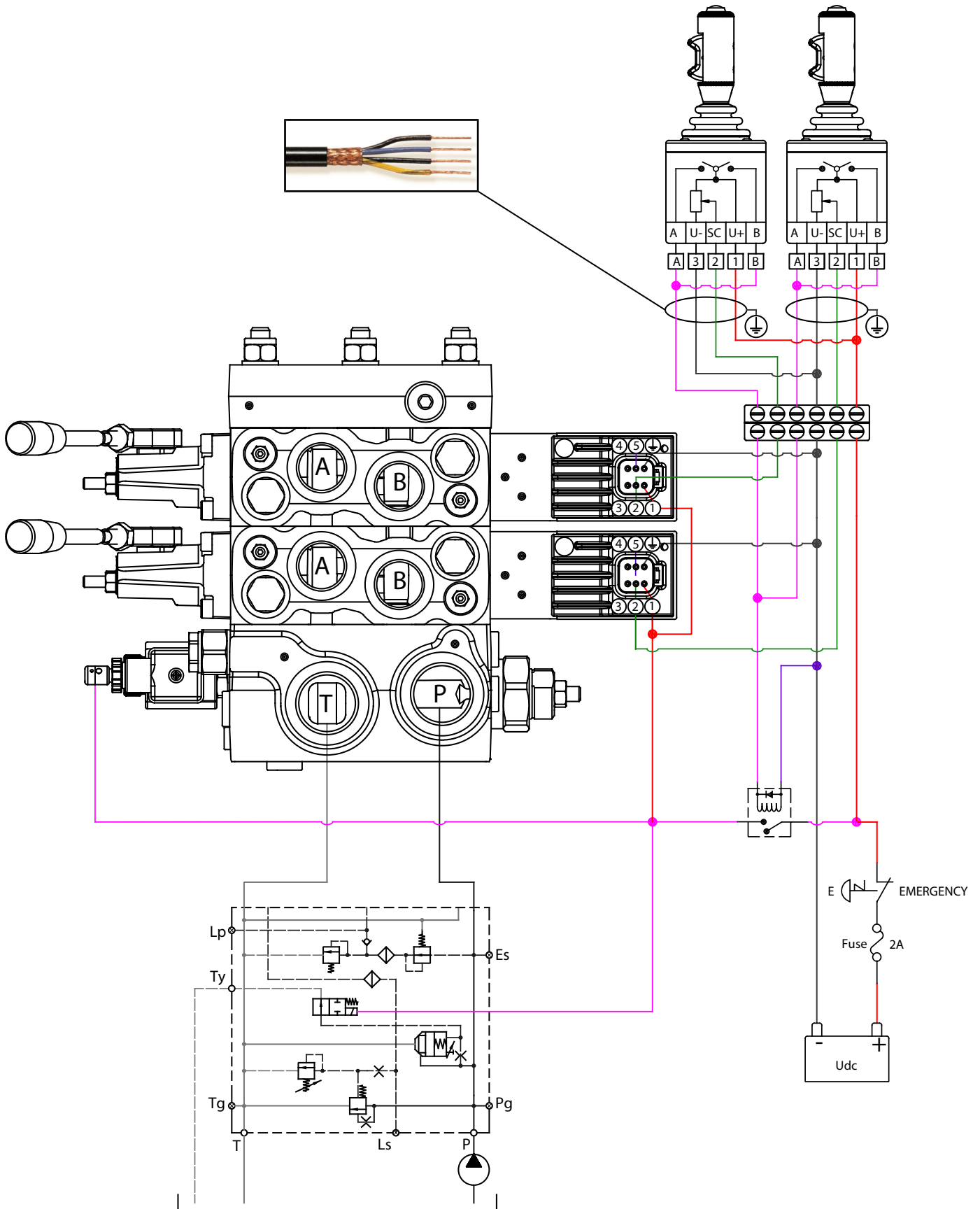

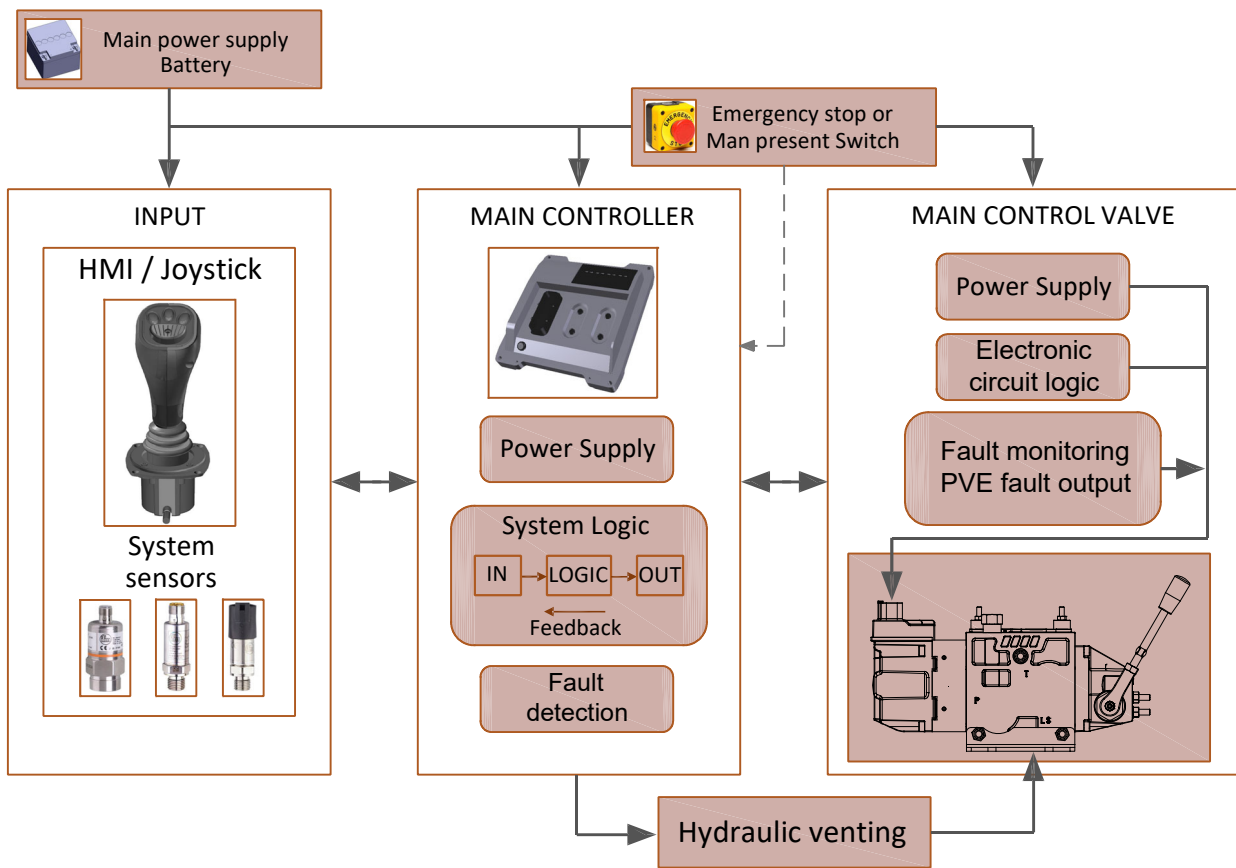

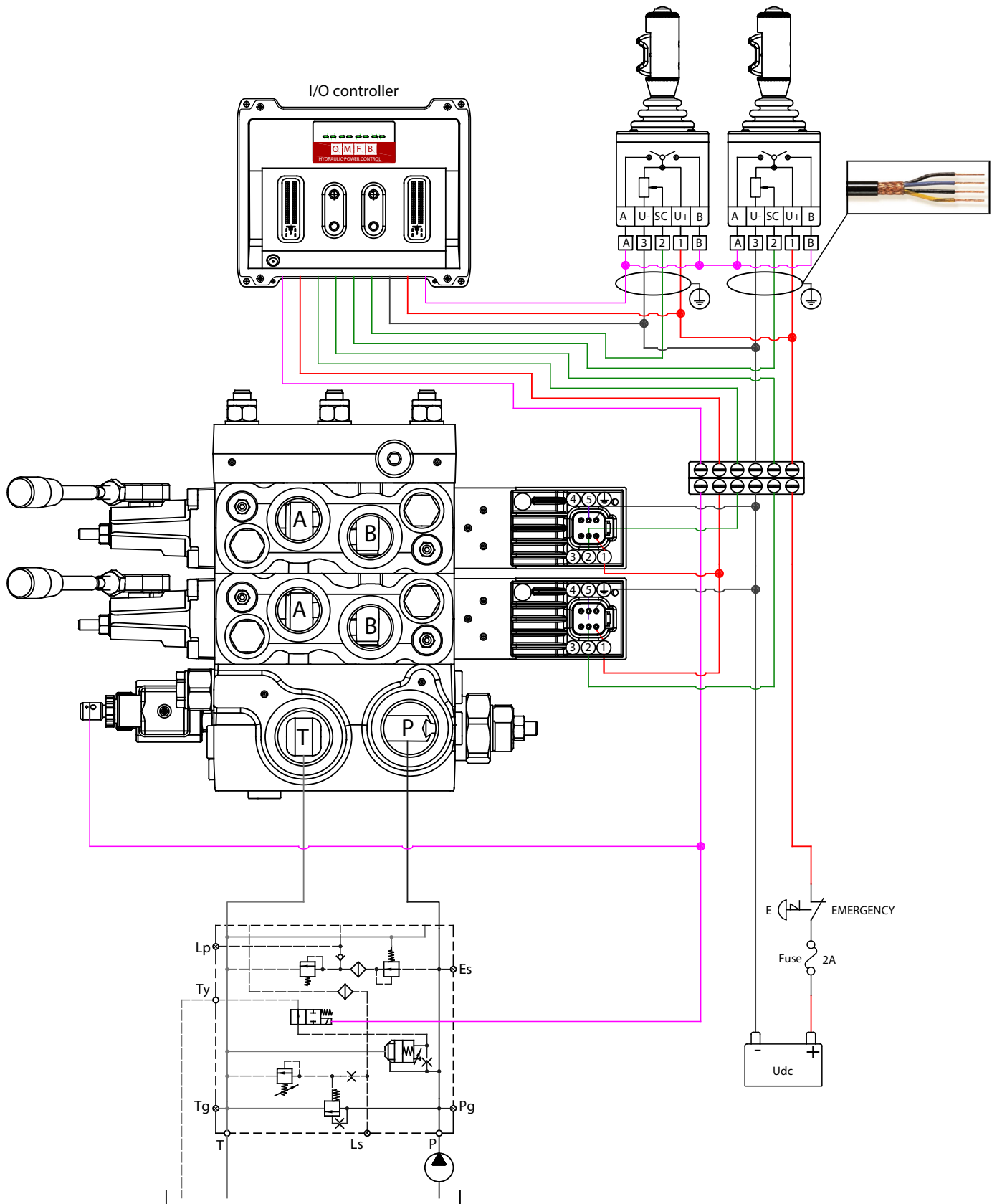

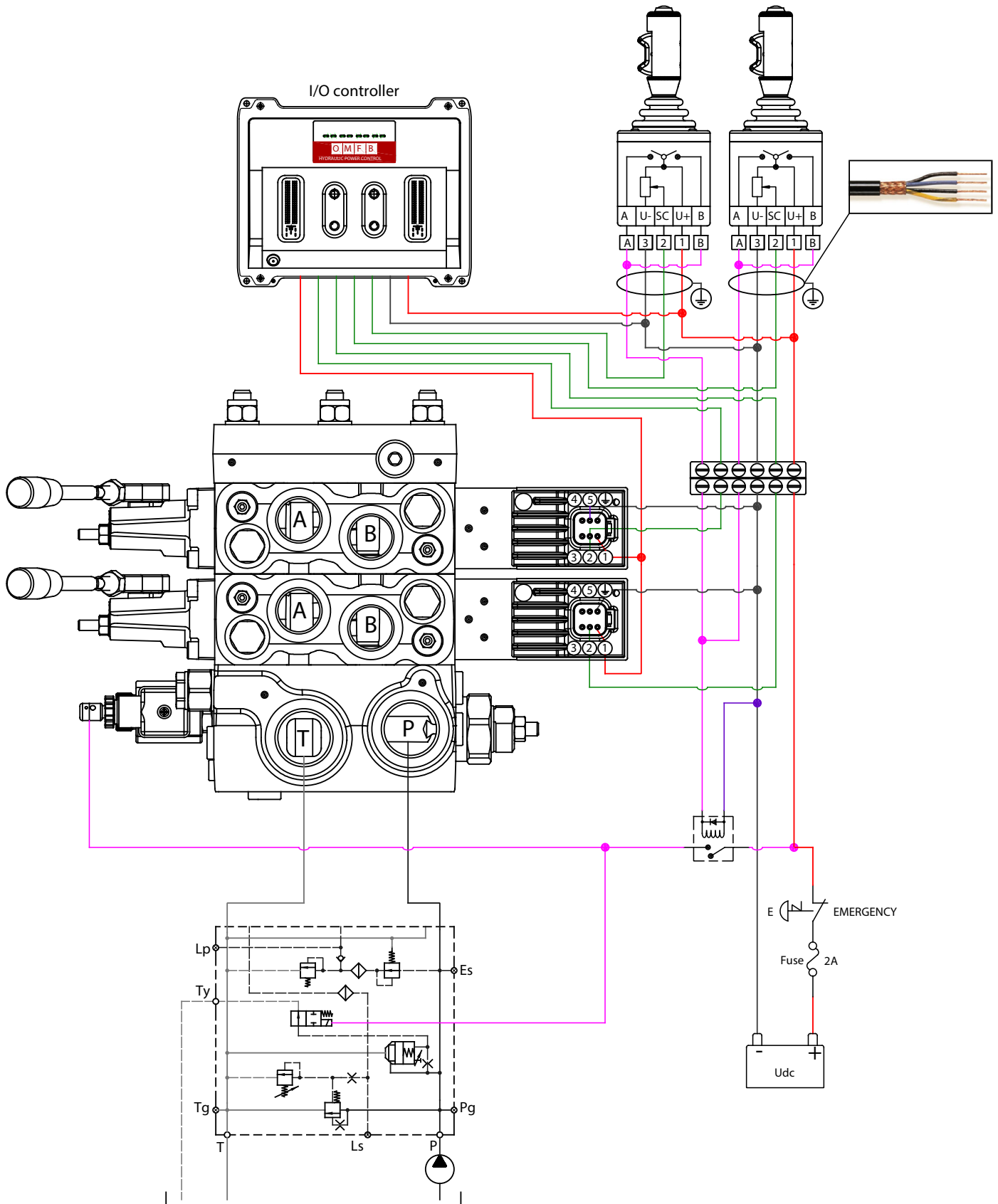

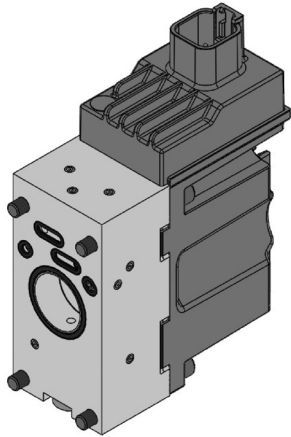

PEAC022 is a proportional open loop spool actuation with integrated electronics that operates the main spool movement according to an electrical signal coming from a remote control.

The input signal by means of the PCB and the two proportional pressure reducing valves, determines the level of the pilot pressure which moves the main spool.

PEAC022 does not have neither the transducer spool position control nor fault monitoring system, this means that any forces which override the pilot pressure spool forces, may change the spool position with no error signal, and the safety of the whole system is left to the operator's visual control, only.

PEAC022 is recommended where a simple proportional control is required, and where hysteresis and reaction time are not so critical.

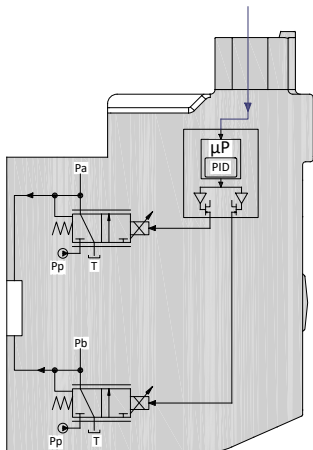

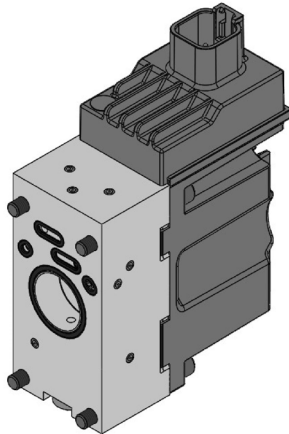

PEAC022 is defined by:

- High spool control accuracy
- EMC performance according to Directive 2014/30/UE
- Quick reaction time
- Integrated PWM/Pulse Width Modulation
- Low electrical power
- Robust and reliable design

PEAC022 Technical data		
Rated supply voltage		10-30 Vdc
Max ripple		5%
Signal control		0-10 V
Range control signal		2,5 V to 7,5 V
Neutral spool position		5 V
Max threshold signal, A port		1 V
Max threshold signal, B port		1 V
Max current signal @ rated voltage		48 mA
Input capacitor		100 nF
Signal control impedance		25 kΩ
Power consumption		8,7 W
Heat insulation		Class H (180°C)
Duty cycle		ED 100%
Max current consumption		650 mA
Current consumption in neutral position		80 mA
Coil impedance @ 20°C		8,9 Ω
Dither frequency		50-200 Hz
Recommended frequency		100 Hz
Enclosure degree	(Electrical wiring excepted)	IP 66 - IP 67 - IP 69K
Weight cast iron body		1,8 kg
Weight aluminium body		1,3 kg
Bootloader function, debugging parameters and set-up function available only with Deutsch connector DT06-6S		
Reaction time (constant voltage)	From neutral position to max spool travel	110 - 140 ms
	From max spool travel to neutral	70 - 90 ms
Reaction time (neutral switch)	From neutral position to max spool travel	130 - 170 ms
	From max spool travel to neutral	70 - 90 ms

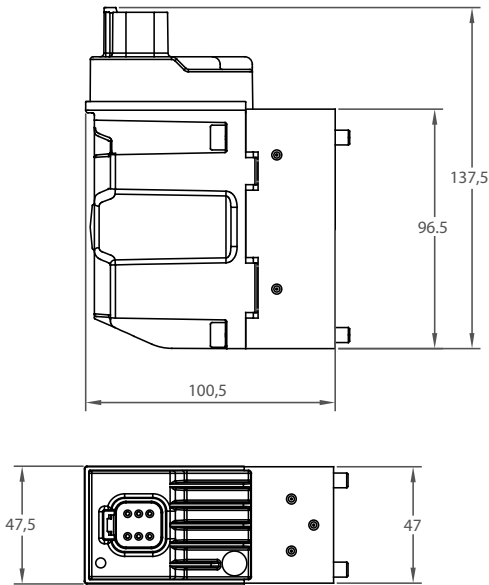

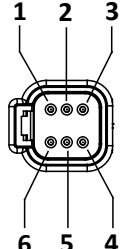
Deutsch connector DT06-6S Enclosure degree IP 69K PIN-assignment		
	1	Power supply
	2	Input signal control
	3	CAN-high
	4	CAN-low
	5	Free
	6	Ground

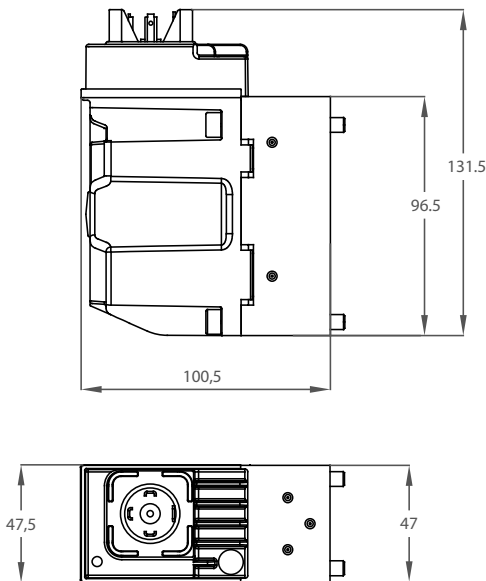

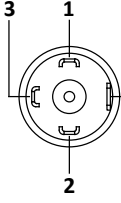
Hirschmann connector DIN 43650 Enclosure degree IP 65 PIN-assignment		
	1	Power supply
	2	Input signal control
	3	Free
	4	Ground

Connector version	Code numbers			
	Active version		Passive version	
	Cast-iron body	Aluminium body	Cast-iron body	Aluminium body
Deutsch DT06-6S	PEAC0042000	PEAC1042000	PEAC0032000	PEAC1032000
DIN 43650	PEAC0042200	PEAC1042200	PEAC0032200	PEAC1032200

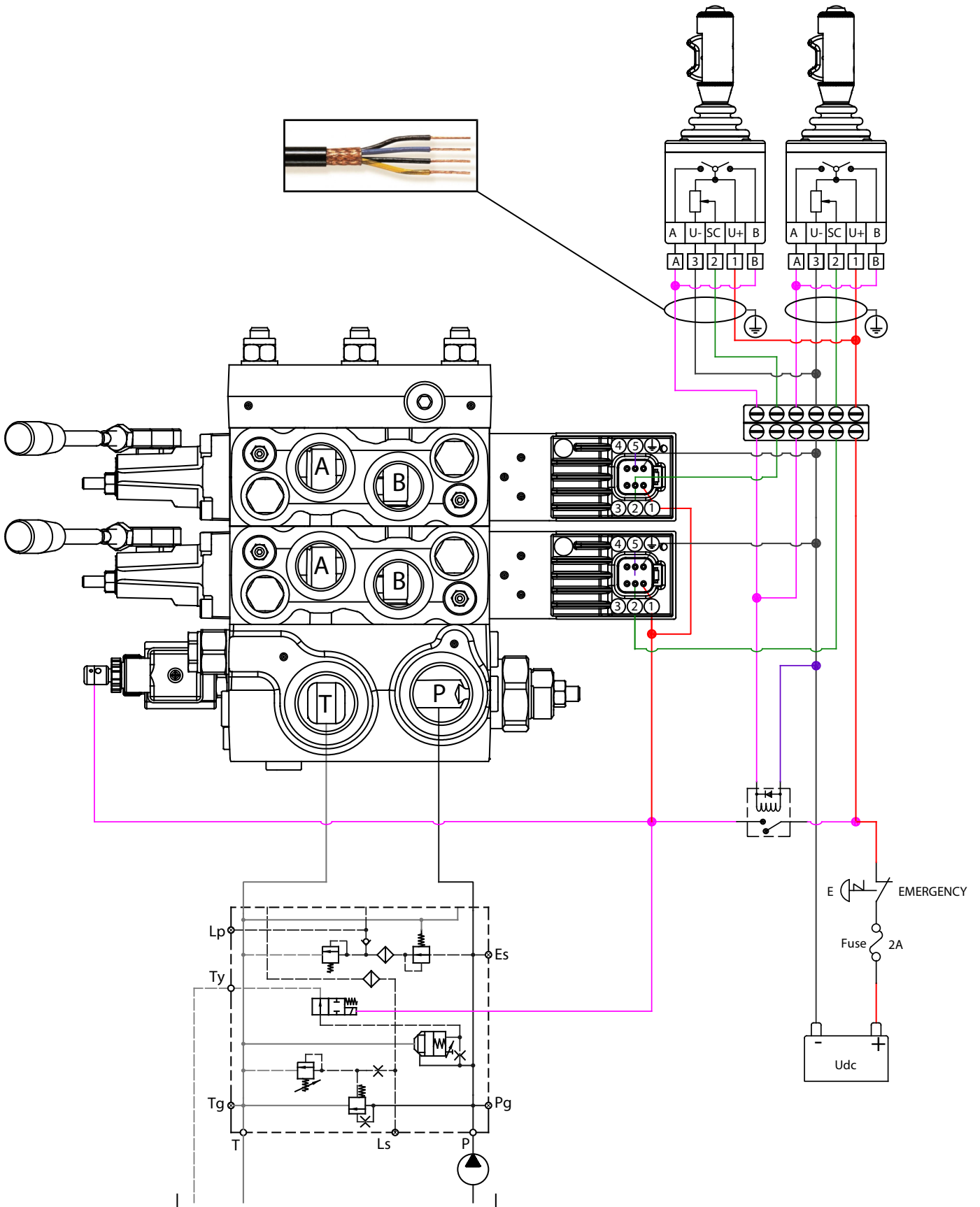

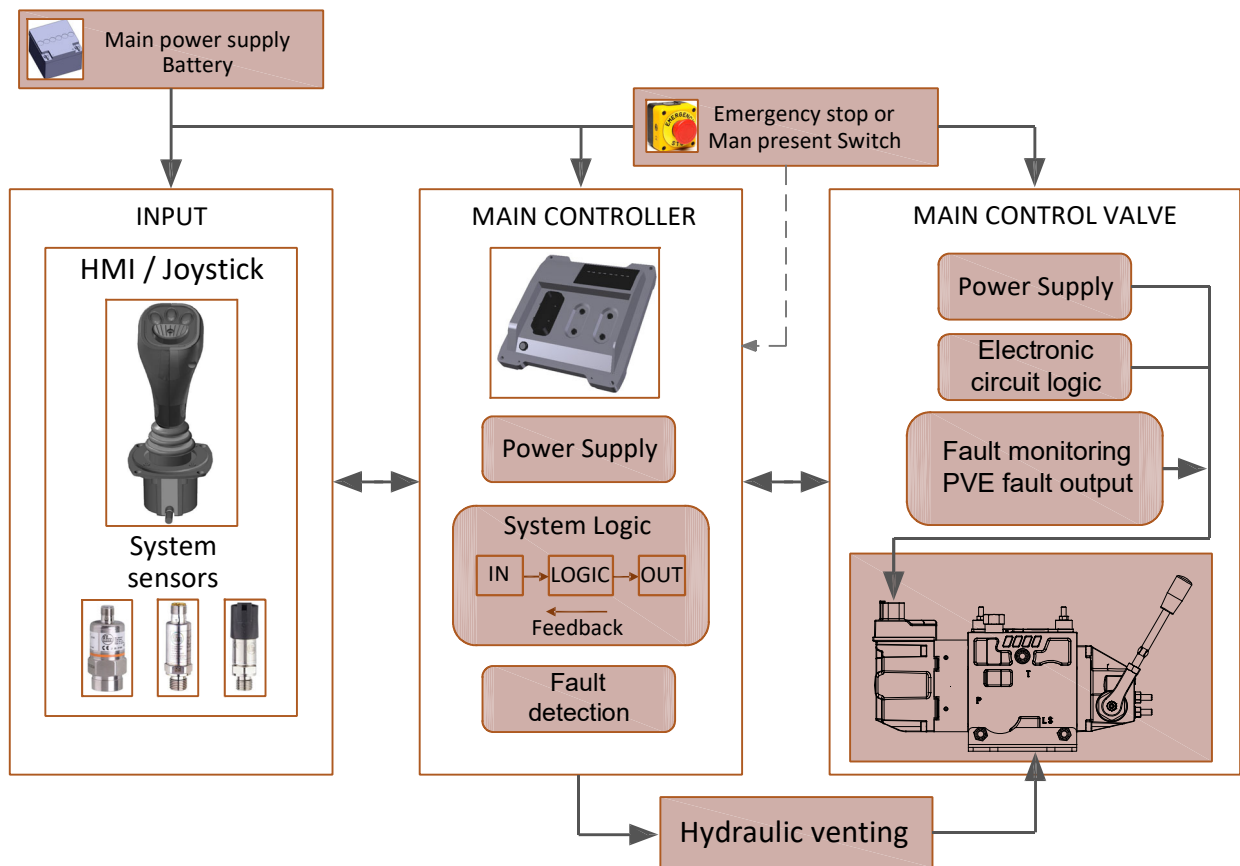

PDV114 - PEAC022 Electro-hydraulic proportional actuation
Electrical wiring diagram with OMFB I/O controller
Input signal 0 ÷ 10 V

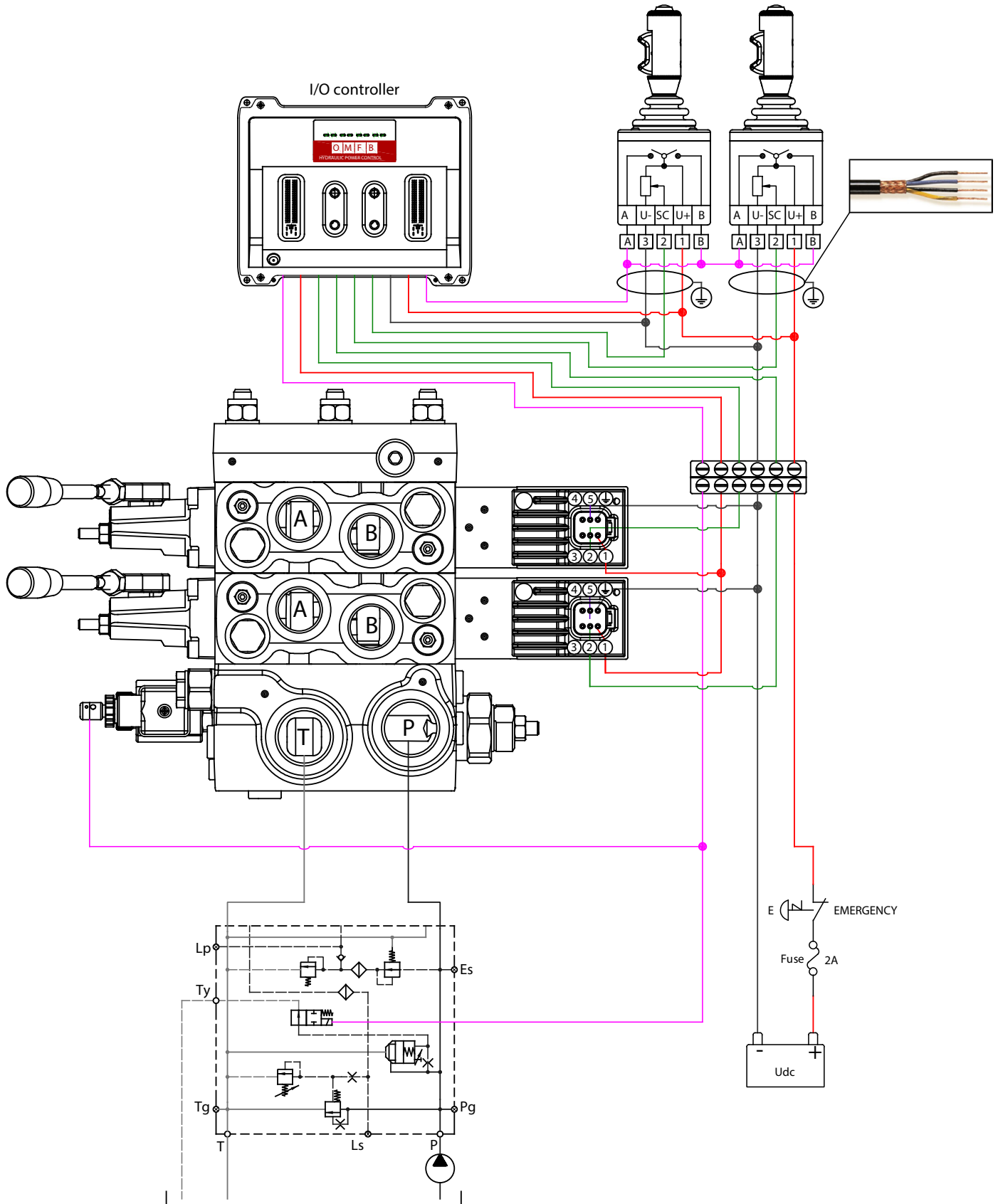

PDV114 - PEAC022 Electro-hydraulic proportional actuation
Electrical wiring diagram with OMFB I/O controller
Input signal 0 ÷ 10 V

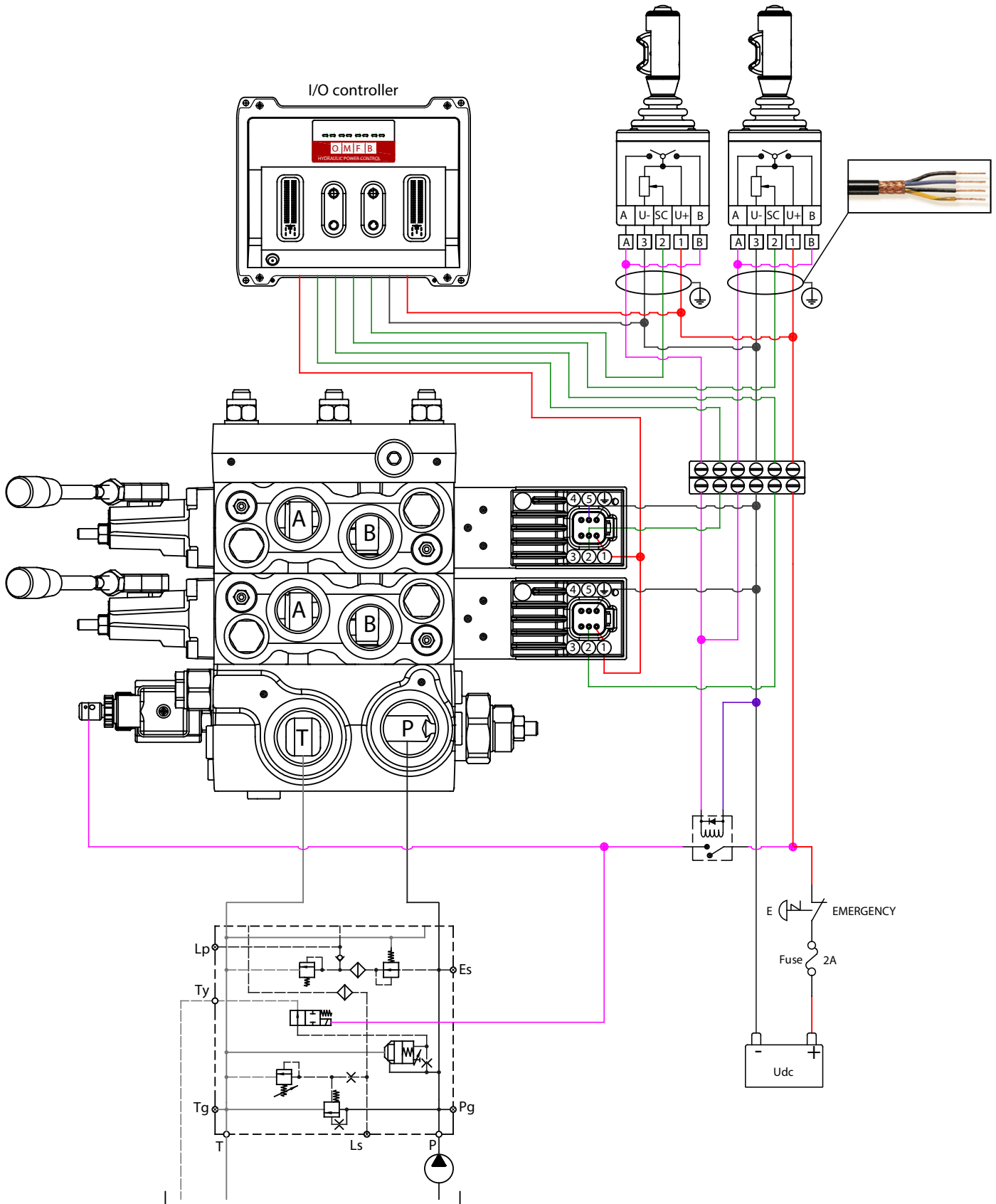

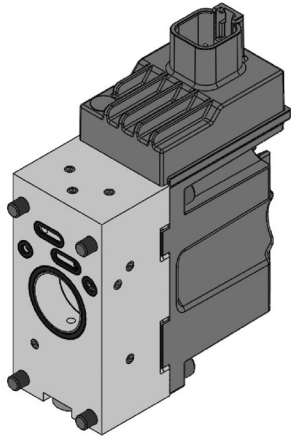

PEAC026 is a proportional open loop spool actuation with integrated electronics that operates the main spool movement according to an electrical signal coming from a remote control.

The input signal by means of the PCB and the two proportional pressure reducing valves, determines the level of the pilot pressure which moves the main spool.

PEAC026 does not have neither the transducer spool position control nor fault monitoring system, this means that any forces which override the pilot pressure spool forces, may change the spool position with no error signal, and the safety of the whole system is left to the operator's visual control, only.

PEAC026 is recommended where a simple proportional control is required, and where hysteresis and reaction time are not so critical.

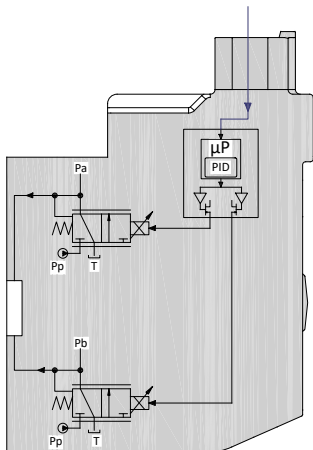

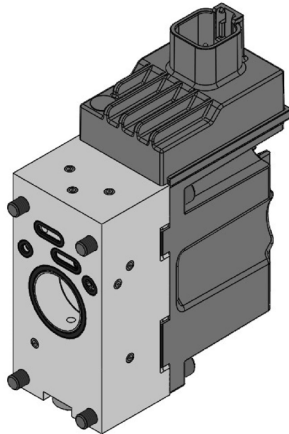

PEAC026 is defined by:

- High spool control accuracy
- EMC performace according to Directive 2014/30/UE
- Quick reaction time
- Integrated PWM/Pulse Width Modulation
- Low electrical power
- Robust and reliable design

PEAC026 Technical data		
Rated supply voltage		10-30 Vdc
Max ripple		5%
Signal control		4-20 mA
Range control signal		4 mA to 20 mA
Neutral spool position		12 mA
Max threshold signal, A port		1,5 mA
Max threshold signal, B port		1,5 mA
Input capacitor		100 nF
Input impedance		220 Ω
Power consumption		8,7 W
Heat insulation		Class H (180°C)
Duty cycle		ED 100%
Max current consumption		650 mA
Current consumption in neutral position		80 mA
Max current start spool travel		140 mA
Max current end spool travel		450 mA
Coil impedance @ 20°C		8,9 Ω
Signal control impedance		50 KΩ
Dither frequency		50-200 Hz
Recommended frequency		100 Hz
Enclouser degree	(Electrical wiring excepted)	IP65 - IP66 - IP69K
Bootloader function, debugging parameters and set-up function available with Deutsch connector DT06-6S, only		
Reaction time (constant voltage)	From neutral position to max spool travel	110 - 140 ms
	From max spool travel to neutral	70 - 90 ms
Reaction time (neutral switch)	From neutral position to max spool travel	130 - 170 ms
	From max spool travel to neutral	70 - 90 ms

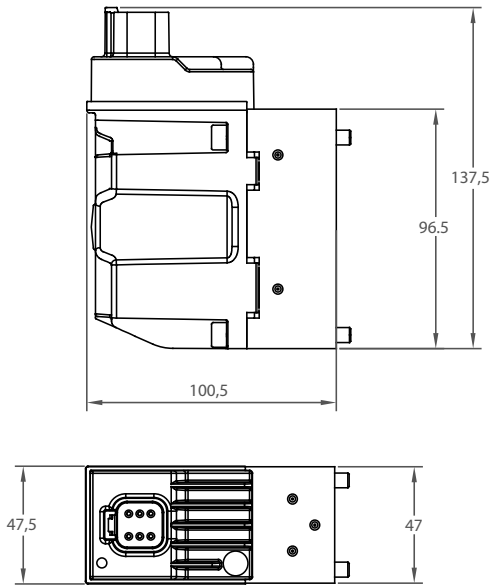

Deutsch connector DT06-6S Enclosure degree IP 69K PIN-assignment		
	1	Power supply
	2	Input signal control
	3	CAN-high
	4	CAN-low
	5	Free
	6	Ground

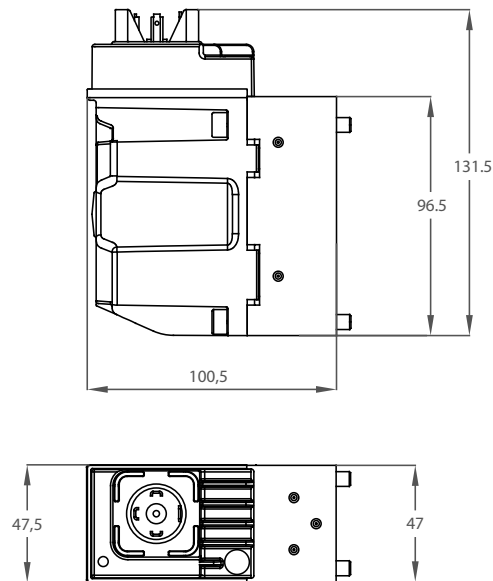

Hirschmann connector DIN 43650 Enclosure degree IP 65 PIN-assignment		
	1	Power supply
	2	Input signal control
	3	Free
	4	Ground

Connector version	Code numbers			
	Active version		Passive version	
	Cast-iron body	Aluminium body	Cast-iron body	Aluminium body
Deutsch DT06-6S	PEAC0046000	PEAC1046000	PEAC0036000	PEAC1036000
DIN 43650	PEAC0046200	PEAC1046200	PEAC0036200	PEAC1036200

PDV114 - PEAC026 Electro-hydraulic proportional actuation.
Input signal control 4-20 mA
Electrical wiring

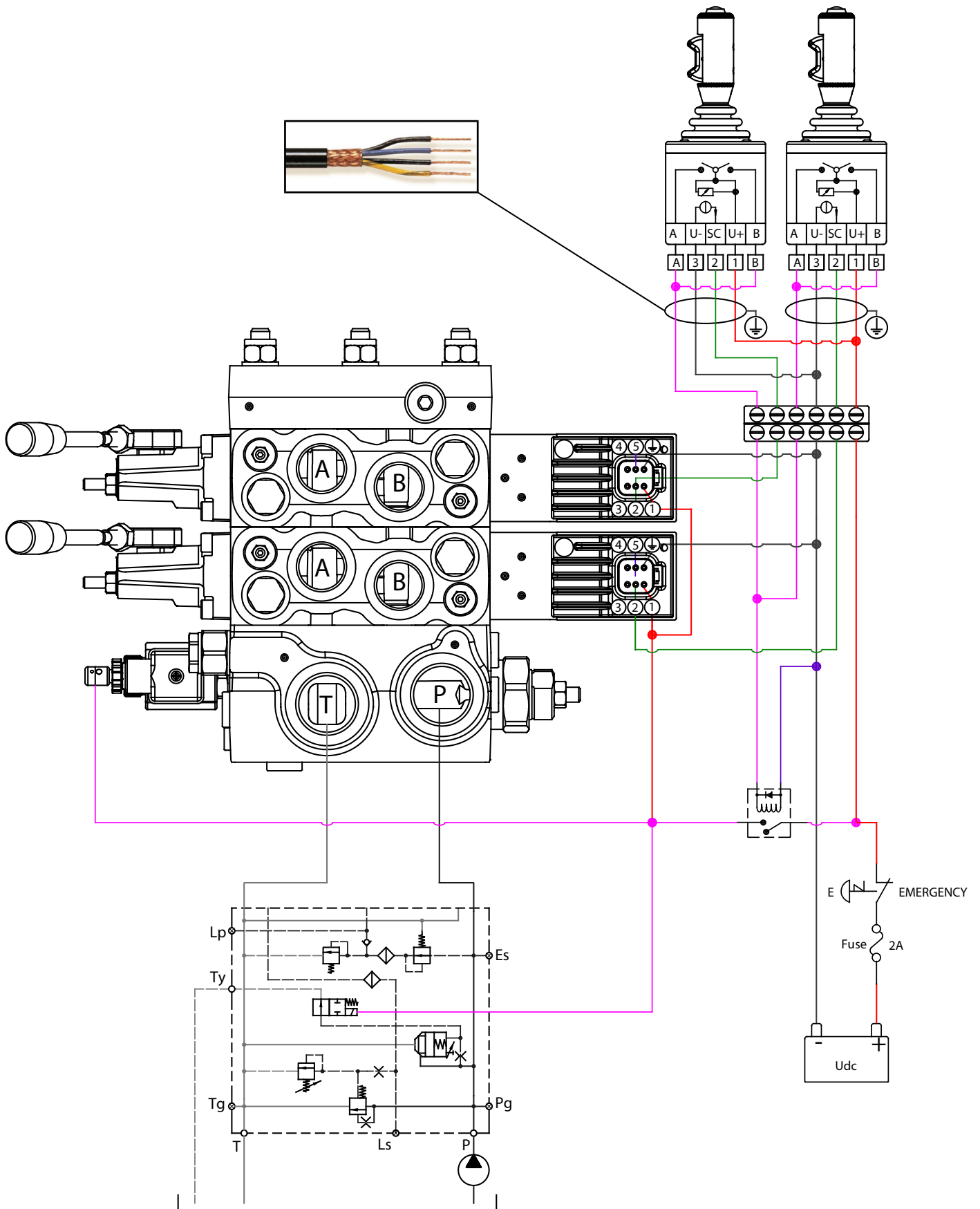

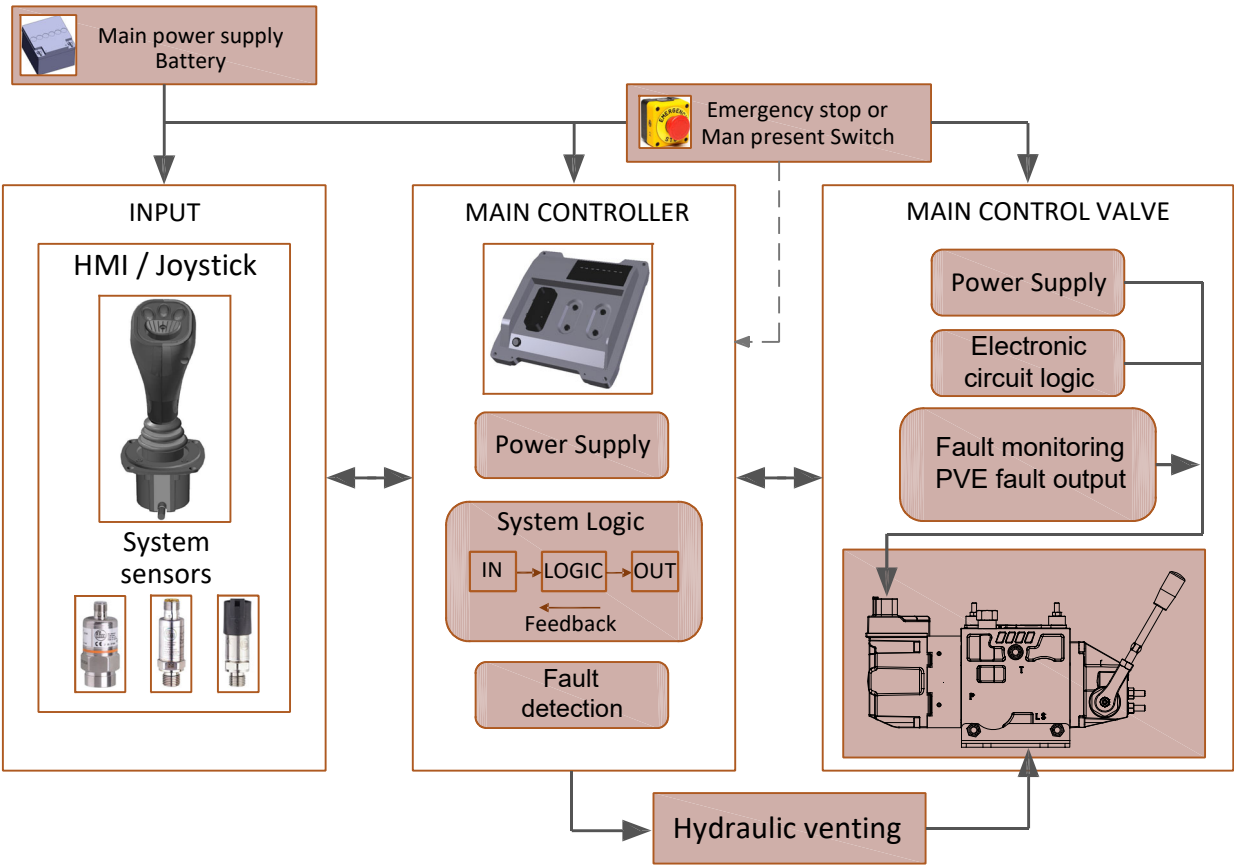

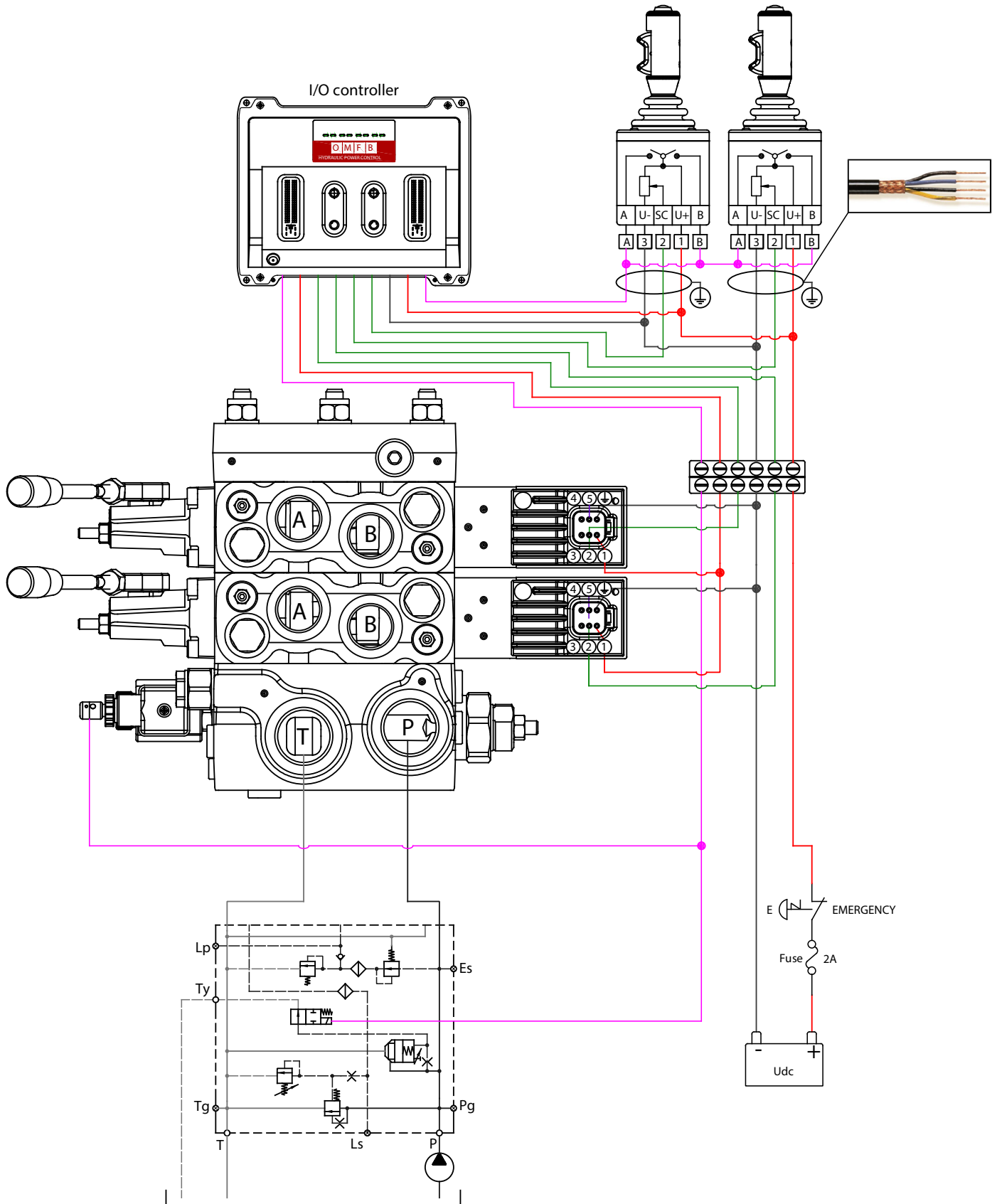

PPDV114 - PEAC026 Electro-hydraulic proportional actuation.
Electrical wiring with OMFB I/O controller
Current input signal 4 ÷ 20 mA

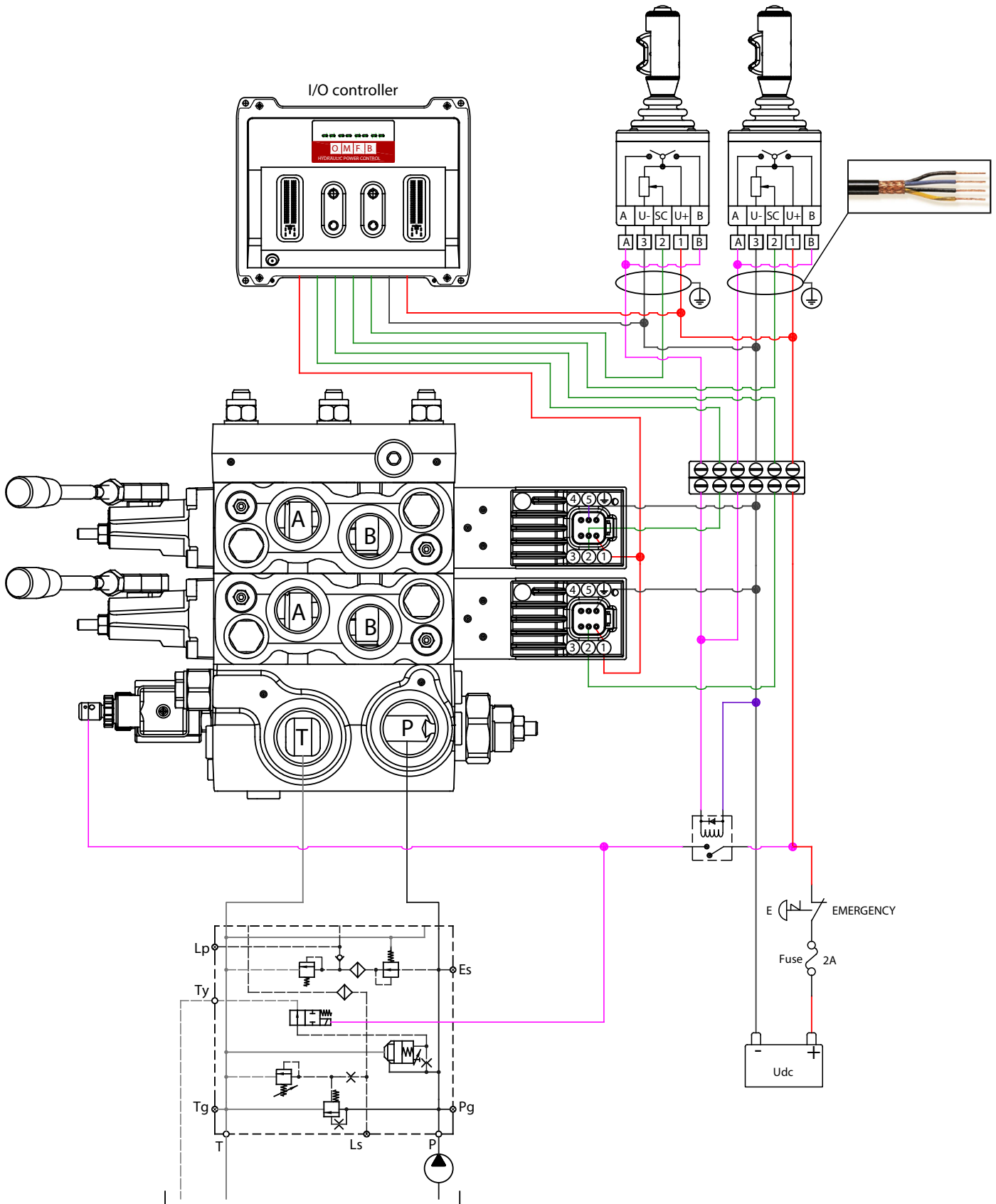

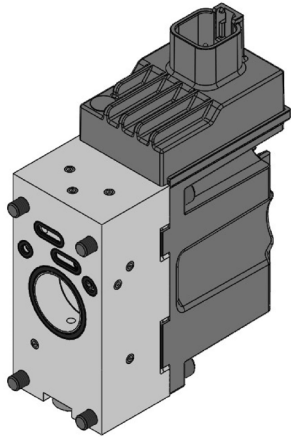

PEAD2 is a proportional open loop spool actuation without integrated electronics that operates the main spool movement according to an electrical signal coming from a remote control.

The input signal by means of the two proportional pressure reducing valves, determines the level of the pilot pressure which moves the main spool.

PEAD2 does not have neither the transducer spool position control nor fault monitoring system, this means that any forces which override the pilot pressure spool forces, may change the spool position with no error signal, and the safety of the whole system is left to the operator's visual control, only.

PEAD2 is recommended where a simple proportional control is required, and where hysteresis and reaction time are not so critical.

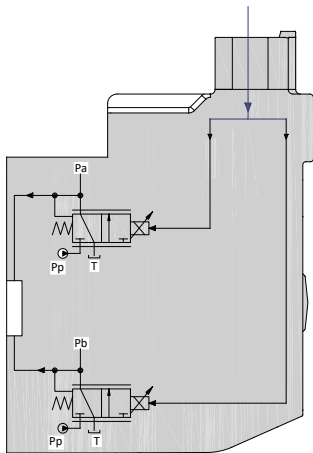

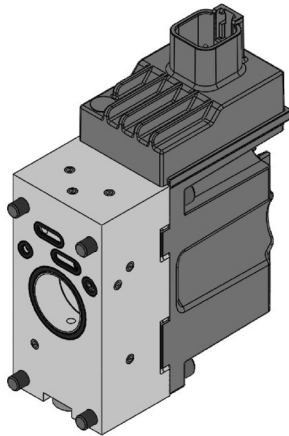

PEAD2 is defined by:

- High spool control accuracy
- EMC performace according to Directive 2014/30/UE
- Quick reaction time
- Integrated PWM/Pulse Width Modulation
- Low electrical power
- Robust and reliable design

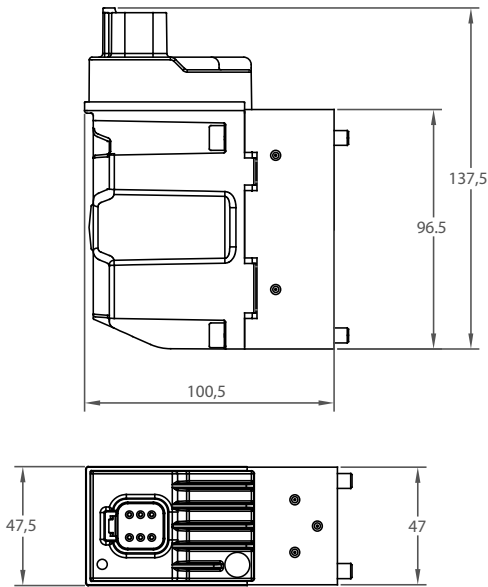
PEAD2 Technical data		
Supply voltage		12 Vdc 24 Vdc
Voltage range		10-16 V 20-30 V
Max ripple		5% 5%
Current consuption at rated voltage		750 mA @ 12 Vdc 400 mA @ 24 Vdc
Power consumption		9 W 9,6 W
R @ 20°C		8,9 Ω 35 Ω
Start spool travel		220 mA 140 mA
End spool travel flow control		650 mA 350 mA
Max spool flow in pre-floating position		650 mA 350 mA
Spool floating position		750 mA 400 mA
Heat insulation		Class H (180°C)
Oil temperature (Recommended)		20 ÷ 60 °C
Oil temperature (Min)		-30 °C
Oil temperature (Max)		80 °C
Ambient temperature		-30 ÷ 60 °C
PWM frequency		50 ÷ 200 Hz
Best frequency		100 Hz
Duty cycle		100% ED
Plug connector		6 pins Deutsch or 4 pins DIN
Enclouser degree	(Electrical wiring excepted)	IP69K
Weight cast iron body		1, 8 kg
Weight Aluminium body		1,3 kg
Max current output signal for spool direction moviment		50 mA
Reaction time (constant voltage)	From neutral position to max spool travel	110 - 140 ms
	From max spool travel to neutral	70 - 90 ms
Reaction time (neutral switch)	From neutral position to max spool travel	130 - 170 ms
	From max spool travel to neutral	70 - 90 ms

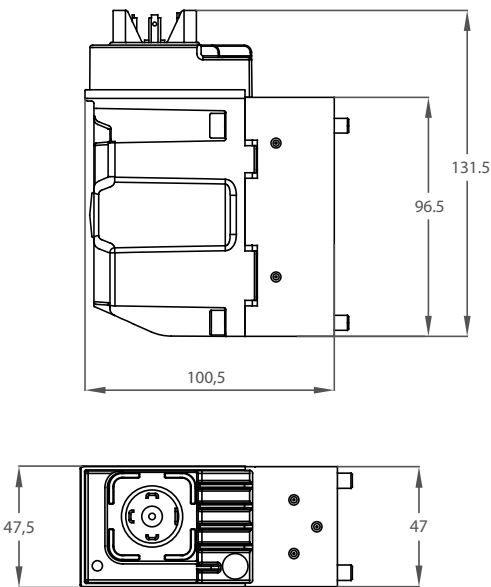

Deutsch connector DT06-6S Enclosure degree IP 69K PIN-assignment		
	1	A port +
	2	Free
	3	A port -
	4	B port +
	5	Free
	6	B port -



Hirschmann connector DIN 43650 Enclosure degree IP 65 PIN-assignment		
	1	A port +
	2	B port +
	3	Free
	4	Ground

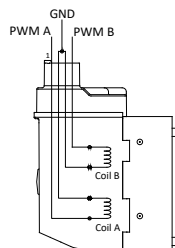

Connector version	Code numbers			
	12 V		24 V	
	Cast-iron body	Aluminium body	Cast-iron body	Aluminium body
Deutsch DT06-6S	PEAD0100001	PEAD1100001	PEAD0200001	PEAD1200001
DIN 43650	PEAD0120001	PEAD1120001	PEAD0220001	PEAD1220001

PDV114 - PEAD2 Electro-hydraulic proportional actuation.
Electrical wiring with OMFB I/O controller - Current input signal for PWM or supply voltage for ON/OFF control

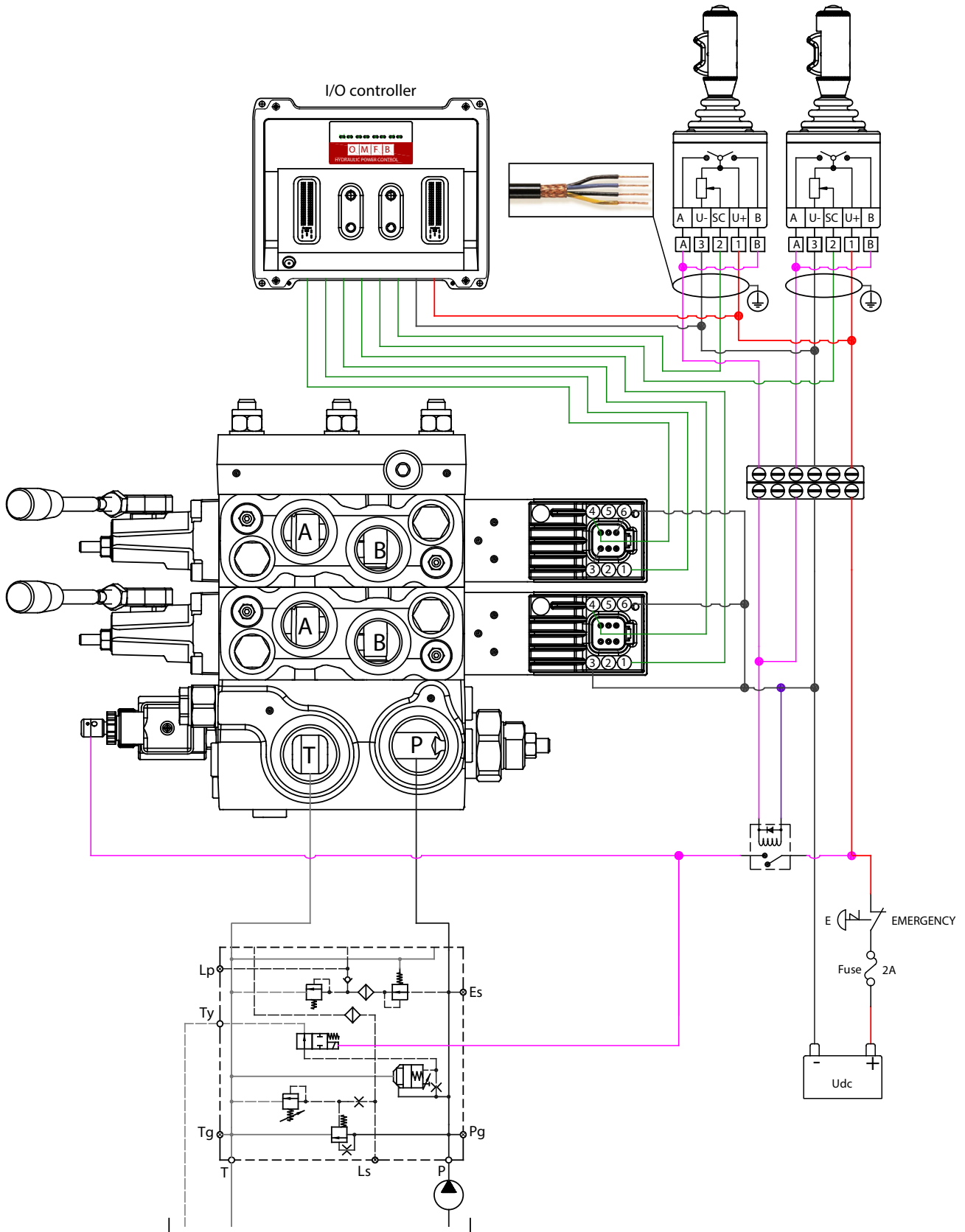

PDV114 - PEAD2 Electro-hydraulic proportional actuation.
Electrical wiring with OMFB I/O controller - Current input signal for PWM or supply voltage for ON/OFF control

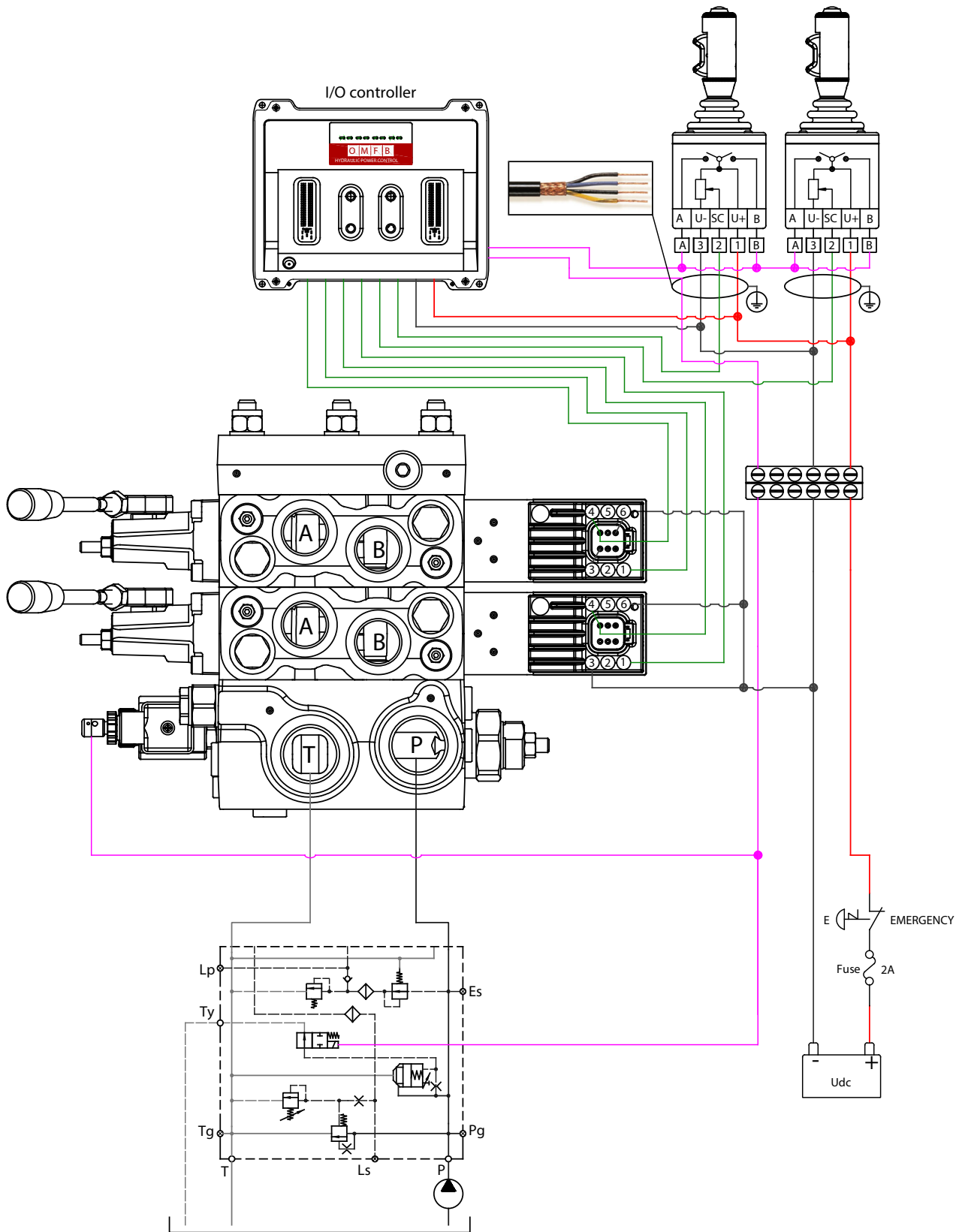

PDV114 - PEAD2 Electro-hydraulic proportional actuation.
Electrical wiring with OMFB I/O controller - Current input signal for PWM or supply voltage for ON/OFF control

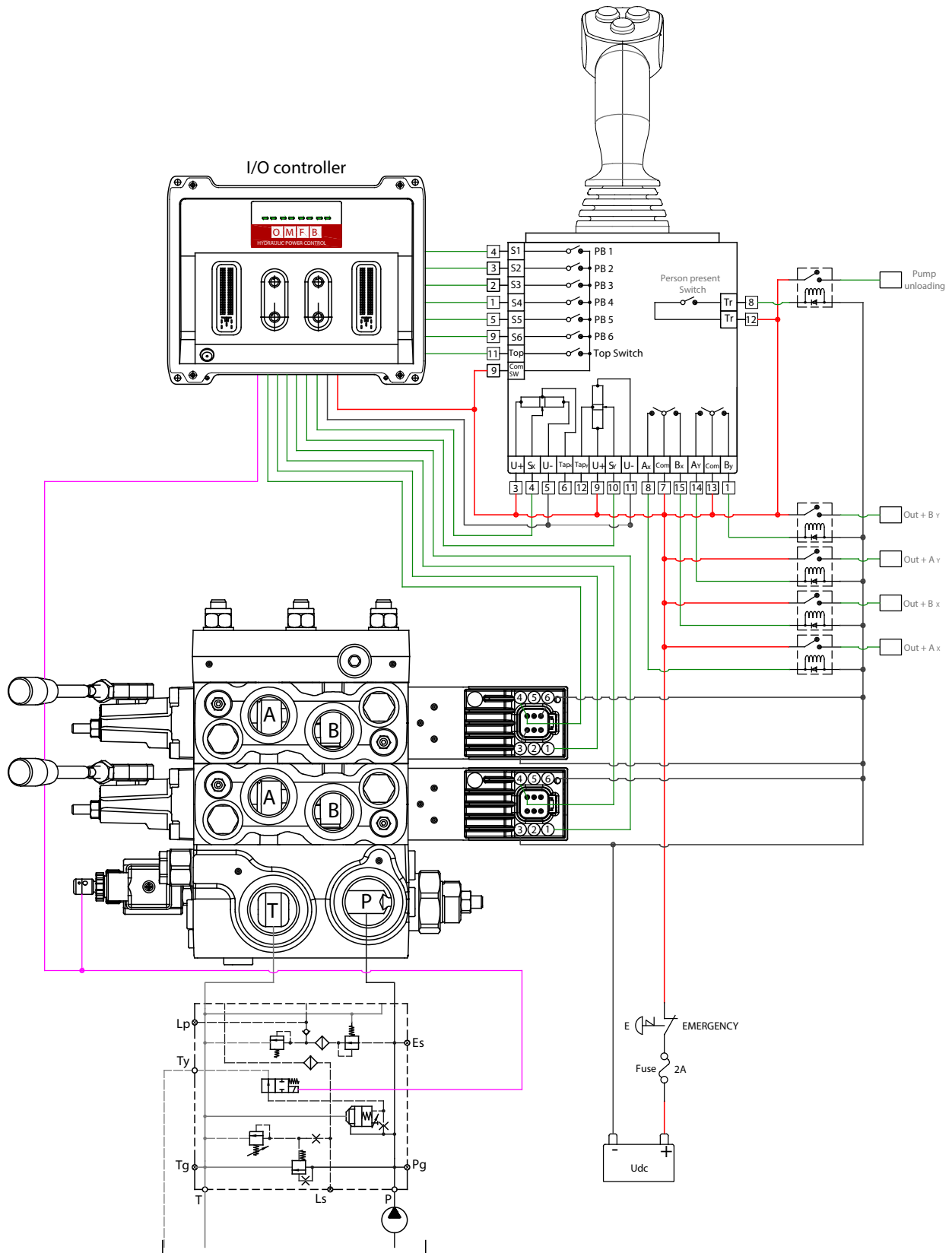

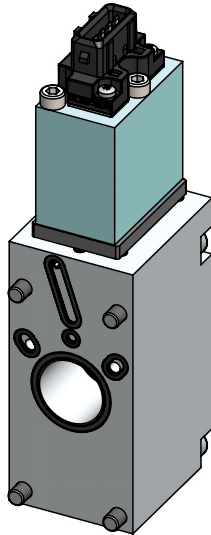

PEAP2 is a proportional open loop spool actuation without integrated electronics that operates the main spool movement according to an electrical signal coming from a remote control.

The input signal by means of the two proportional pressure reducing valves, determines the level of the pilot pressure which moves the main spool.

PEAP2 does not have neither the transducer spool position control nor fault monitoring system, this means that any forces which override the pilot pressure spool forces, may change the spool position with no error signal, and the safety of the whole system is left to the operator's visual control, only.

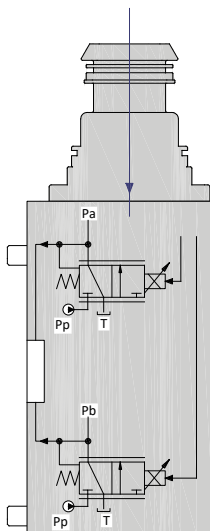

PEAP2 is recommended where a simple proportional control is required, and where hysteresis and reaction time are not so critical.

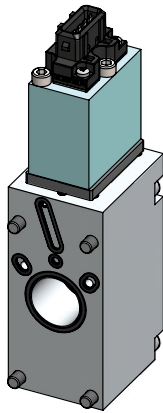

PEAP2 is defined by:

- High spool control accuracy
- EMC performance according to Directive 2014/30/UE
- Quick reaction time
- Integrated PWM/Pulse Width Modulation
- Low electrical power
- Robust and reliable design

PEAP2 Technical data		
Supply voltage	12 Vdc	24 Vdc
Voltage range	10-16 V	20-30 V
Max ripple	5%	5%
Current consumption at rated voltage	1330 mA @ 12 Vdc	630 mA @ 24 Vdc
Power consumption	23 W	21 W
R @ 20°C	6,3 Ω	27 Ω
Start spool travel	220 mA	140 mA
End spool travel flow control	1330 mA	550 mA
Max spool flow in pre-floating position	1330 mA	630 mA
Spool floating position	750 mA	400 mA
Heat insulation	Class H (180°C)	
Oil temperature (Recommended)	-20 ÷ 60 °C	
Oil temperature (Min)	-30 °C	
Oil temperature (Max)	80 °C	
Ambient temperature	-30 ÷ 60 °C	
PWM frequency	50 ÷ 200 Hz	
Best frequency	100 Hz	
Duty cycle	100% ED	
Plug connector	Amp Junior Power Timer 4 pins	
Enclouser degree	(Electrical wiring excepted) IP69K	
Max current output signal for spool direction moviment	50 mA	
Reaction time (constant voltage)	From neutral position to max spool travel	110 - 140 ms
	From max spool travel to neutral	70 - 90 ms
Reaction time (neutral switch)	From neutral position to max spool travel	130 - 170 ms
	From max spool travel to neutral	70 - 90 ms

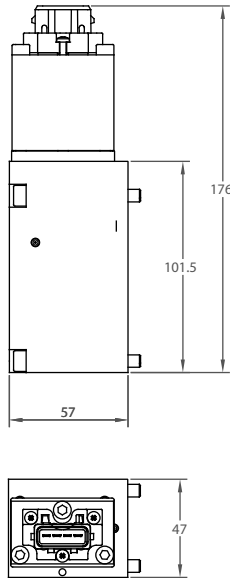

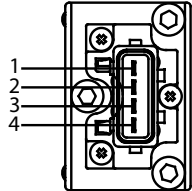
Amp Junior Power Timer 4 pin connector Enclosure degree IP 65 PIN-assignment	
	1 A port +
	2 A port -
	3 B port -
	4 B port +

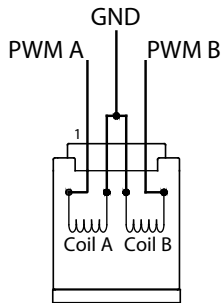

Connector version	Code numbers			
	12 V		24 V	
	Cast-iron body	Aluminium body	Cast-iron body	Aluminium body
AMP Junior timer 4 Pin	PEAP0312001	PEAP1312001	PEAP0412001	PEAP1412001

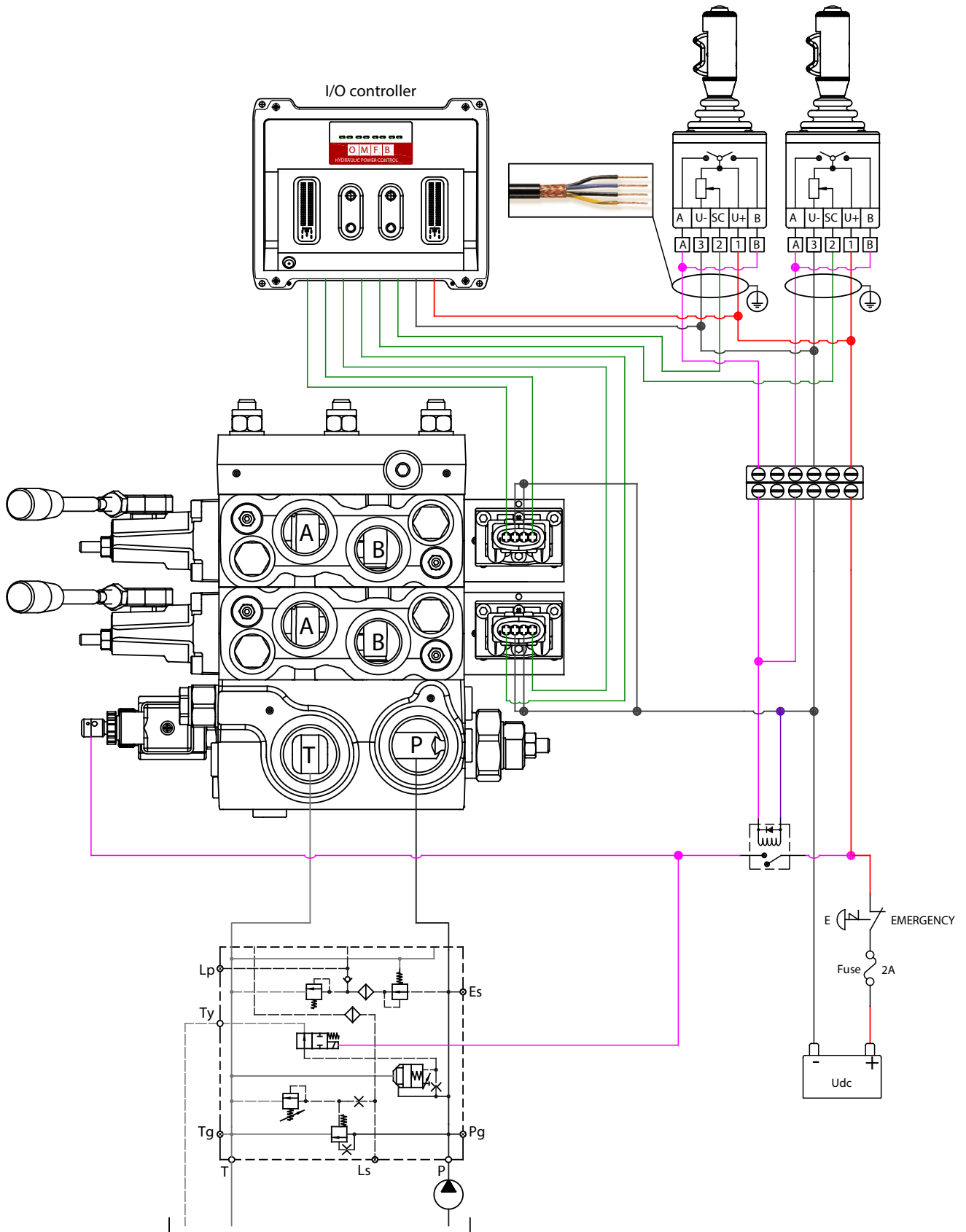

PDV114 - PEAP2 Electro-hydraulic proportional actuation
Electrical wiring with OMFB I/O controller - Current input signal for PWM or supply voltage for ON/OFF control

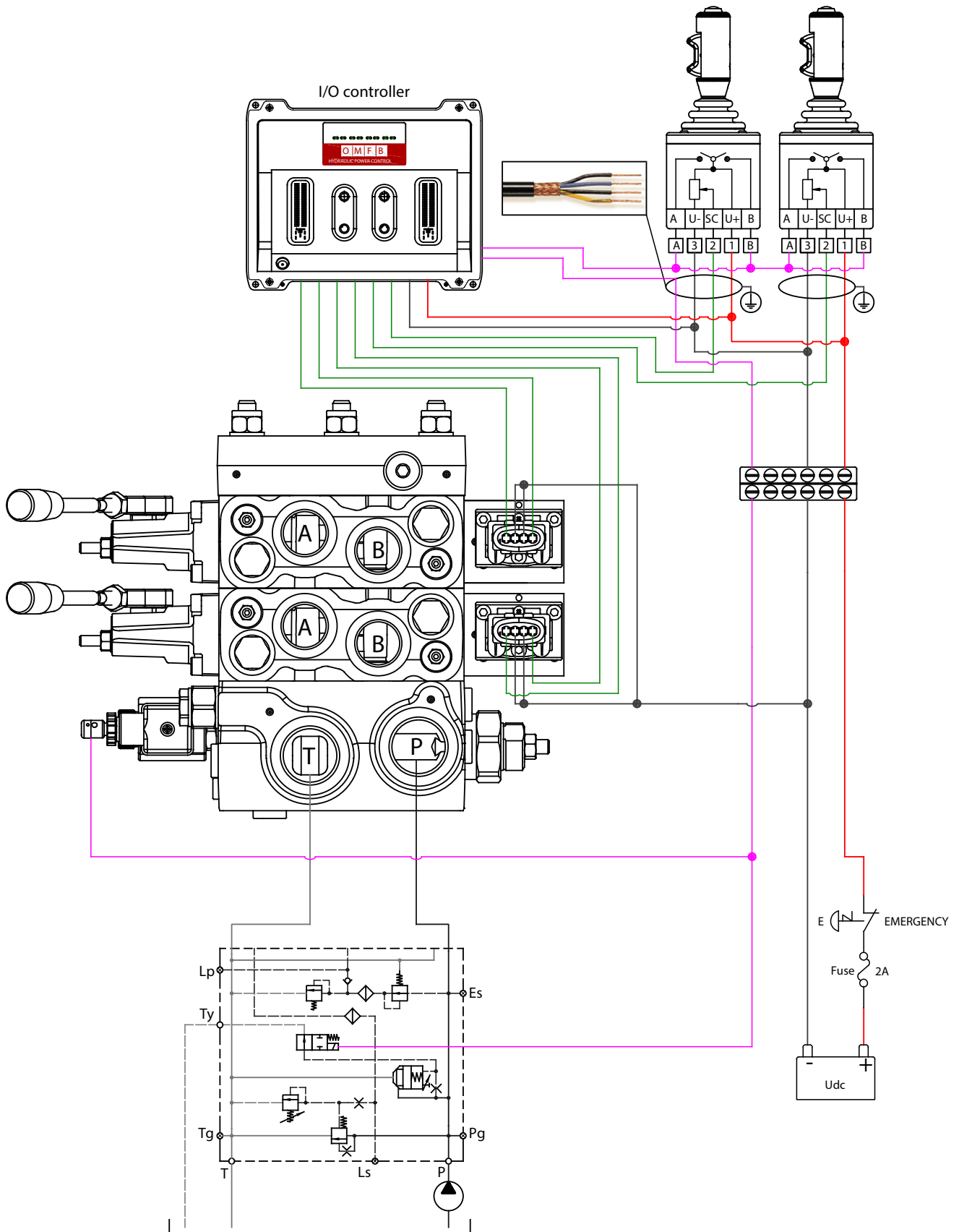

PDV114 - PEAP2 Electro-hydraulic proportional actuation

Electrical wiring with OMFB I/O controller - Current input signal for PWM or supply voltage for ON/OFF control

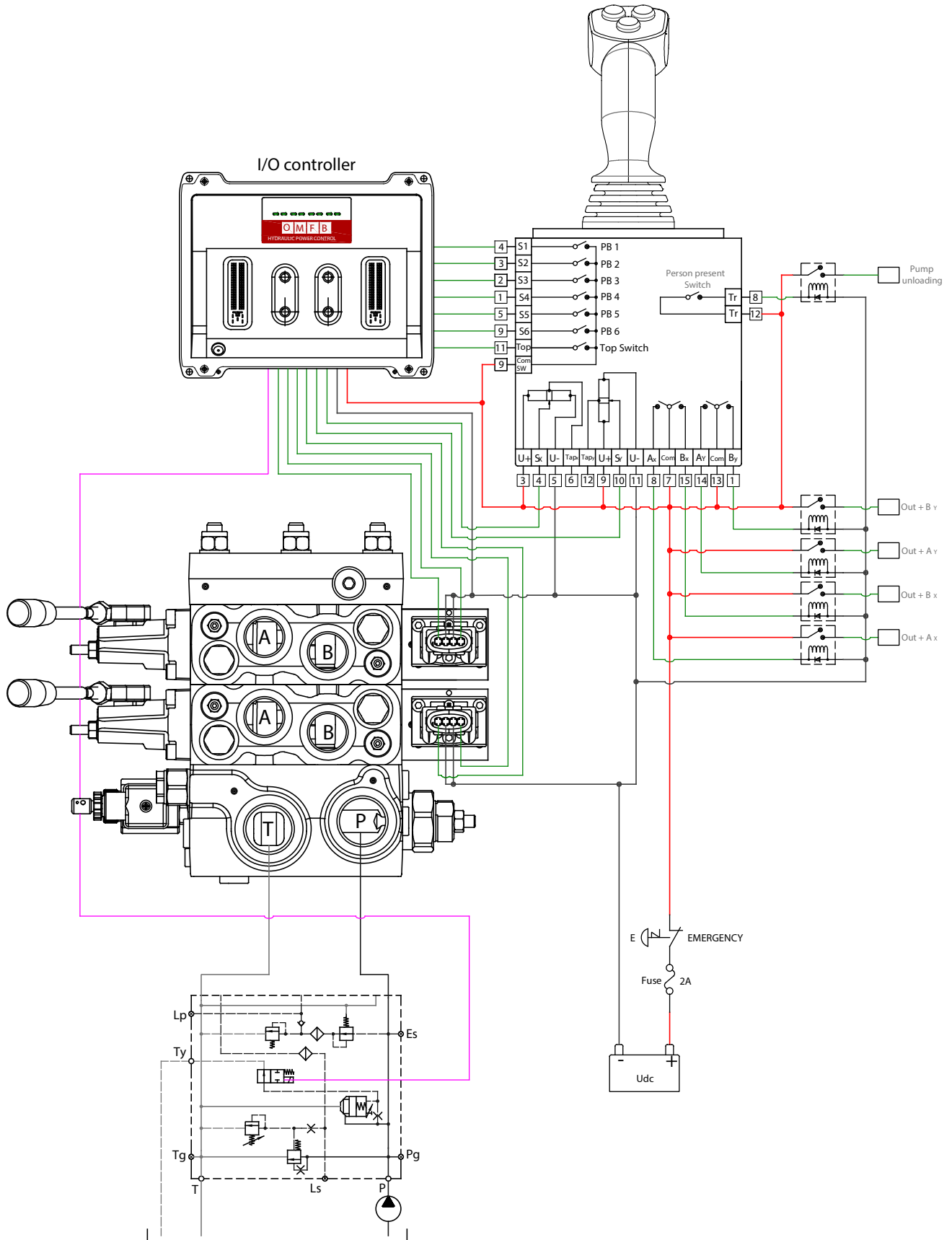

PDV114 Proportional valve
Overall dimensions drawing with standard inlet section
Right assembly version

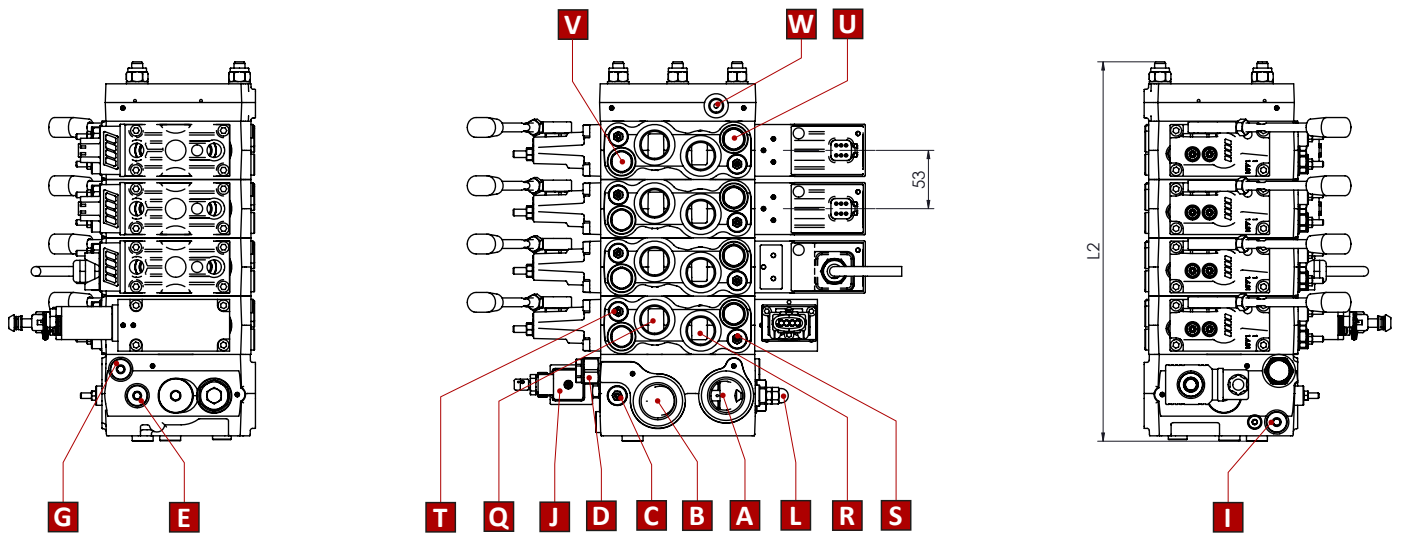
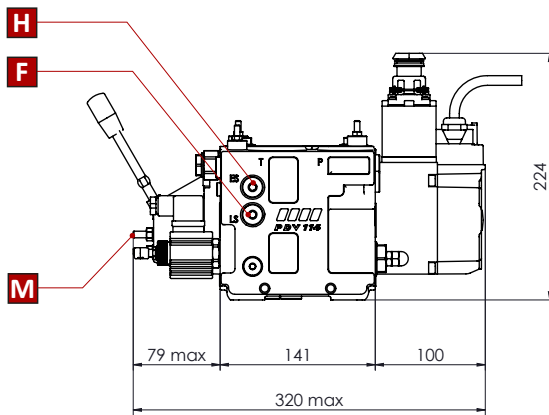
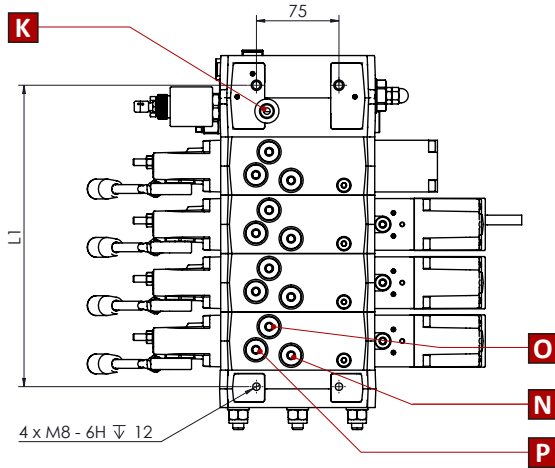

PDW		1	2	3	4	5	6	7	8	9	10	11	12
L1	mm	180	228	276	324	372	420	468	516	564	612	660	708
	in	7,09	8,98	10,87	12,76	14,65	16,54	18,43	20,31	22,20	24,09	25,98	27,87
L2	mm	200	248	296	344	392	440	488	536	584	632	680	728
	in	7,87	9,76	11,65	13,54	15,43	17,32	19,21	21,10	22,99	24,88	26,77	28,66

- A** = Pump side port - 3/4" BSPP - 17 mm deep [1 1/16 in 12 UN-2B - 0,67 in deep]
B = T port - 3/4" BSPP - 17 mm deep [1 1/16 in 12 UN - 2B - 0,67 in deep]
C = Main pressure relief valve
D = Main pressure reducing valve
E = Pump pressure gauge connection - 1/4" BSPP - 12 mm deep [7/16 in-20 UNF-2B - 0,47 in deep]
F = LS connection 1/4" BSPP - 12 mm deep [7/16 in-20 UNF-2B - 0,47 in deep]
G = External pilot pressure supply connection 1/4" BSPP - 12 mm deep [7/16 in-20 UNF-2B - 0,47 in deep]
H = External feeding main pressure reducing valve 1/4" BSPP - 12 mm deep [7/16 in-20 UNF-2B - 0,47 in deep]
I = Tank pressure gauge connection 1/4" BSPP - 12 mm deep [7/16 in-20 UNF-2B - 0,47 in deep]
J = Electrical LS/pump unloading function
K = Pump unloading drain port, 1/4" BSPP - 12 mm deep [7/16 in-20 UNF - 2B - 0,47 in deep]
L = Pump unloading mechanical override
M = A-B port mechanical flow adjustment
N = LSA
O = LSB } remote pilot pressure connection 1/4" BSPP - 12 mm deep [7/16 in-20 UNF - 2B - 0,47 in deep]
P = LS }
Q = Port A } 1/2" BSPP - 17 mm deep [7/8 in-14 UNF-2B - 0,67 in deep]
R = Port B }
S = LSB } pilot pressure relief valve
T = LSA }
U = Shock/suction valve B port
V = Shock/suction valve A port
W = External drain connection electric actuations - 1/4" BSPP - 12 mm deep [7/16 in-20 UNF-2B - 0,47 in deep]

PDV114 with open centre inlet section (fixed displacement pump),
pump unloading system, pilot oil supply for electro-hydraulic
spool actuations

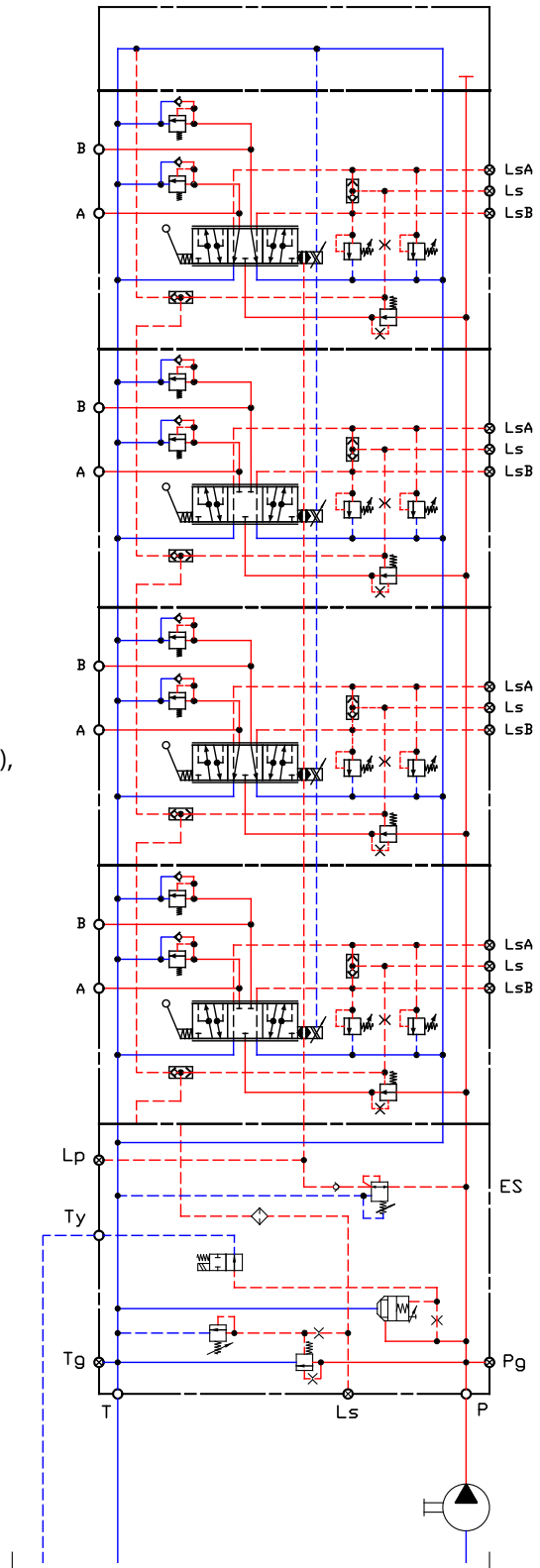

PDV114 with closed centre inlet section (variable displacement pump), pilot oil supply for electro-hydraulic spool actuations

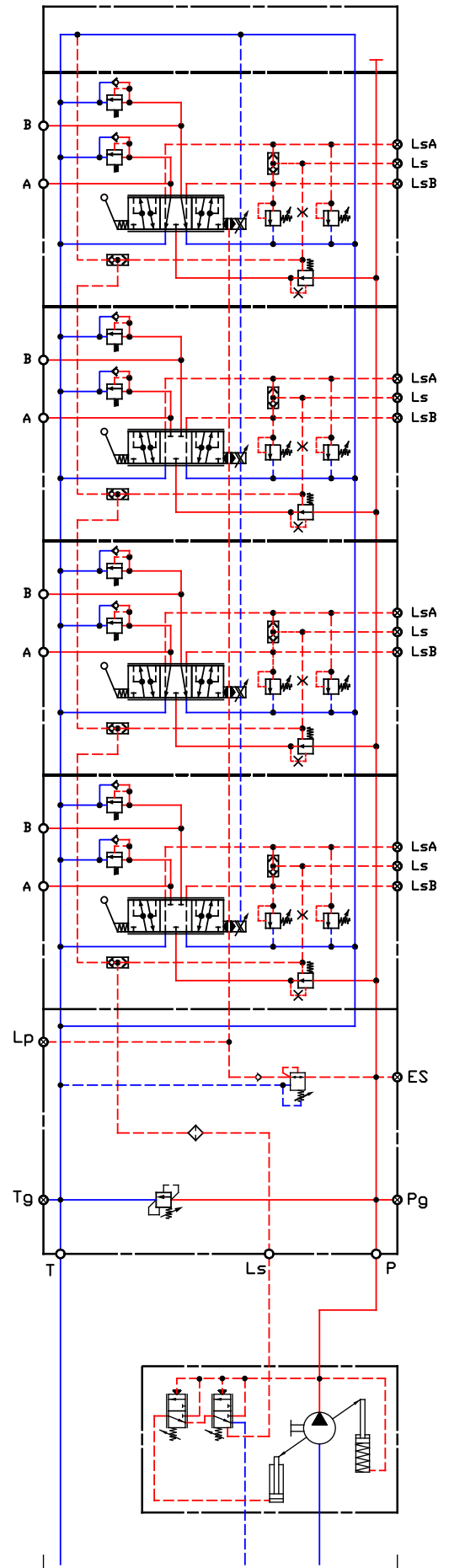

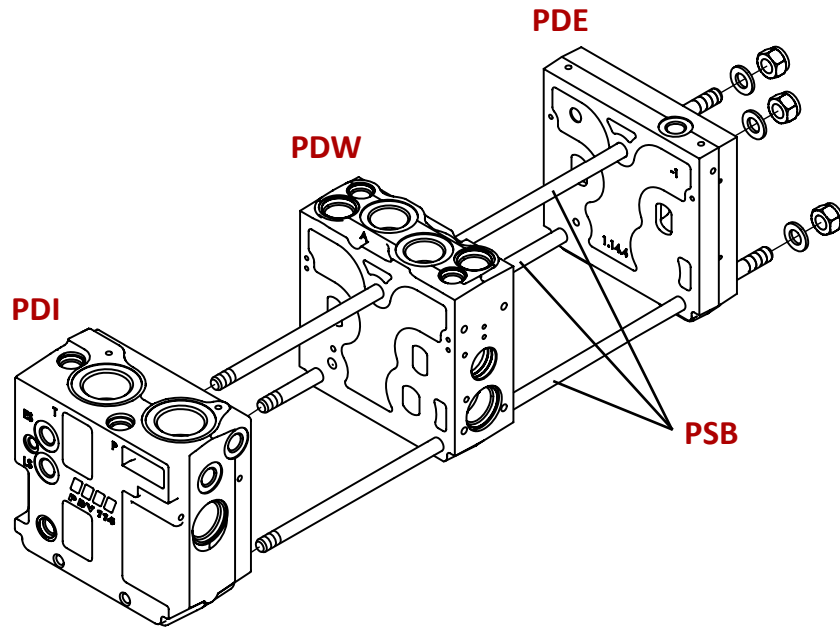

PDW	Code numbers	Tightening torque
1	PSB10010000	<p>25 ± 2 Nm 220 ± 18 lb*in</p>
2	PSB10020000	
3	PSB10030000	
4	PSB10040000	
5	PSB10050000	
6	PSB10060000	
7	PSB10070000	
8	PSB10080000	
9	PSB10090000	
10	PSB10100000	



HYDRAULIC POWER CONTROL

PDV114 Proportional valve
Overall dimensions drawing with double inlet and MID end section

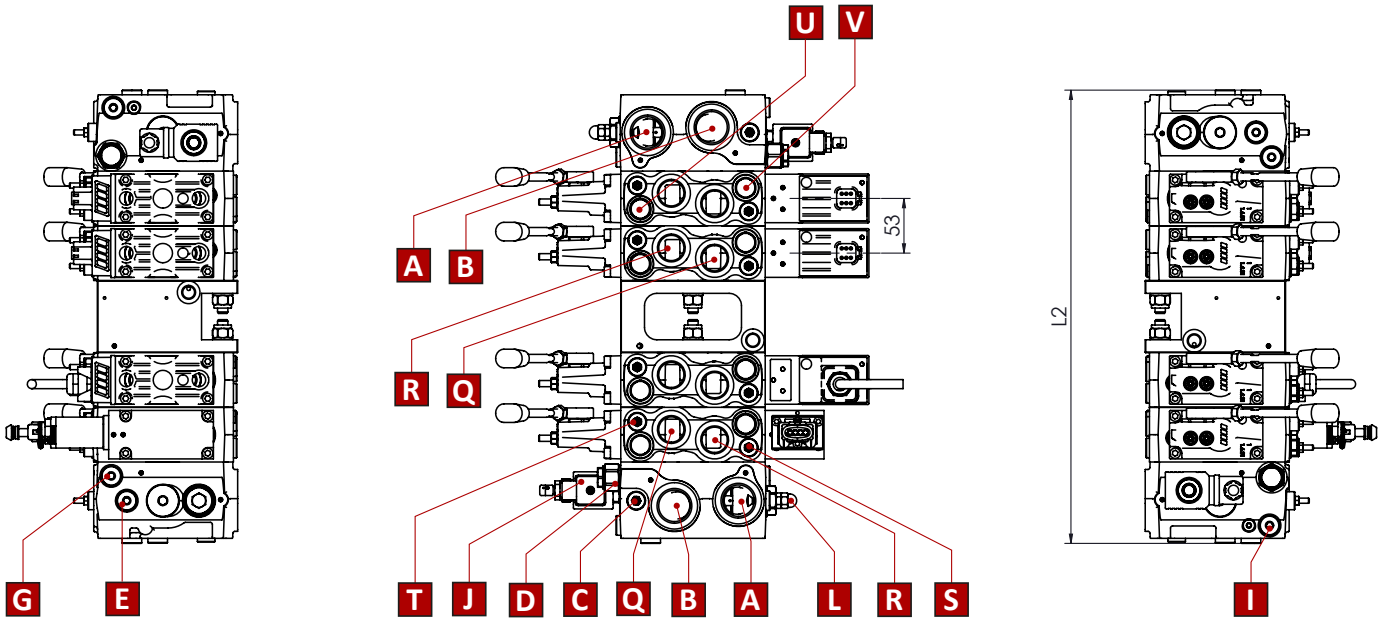
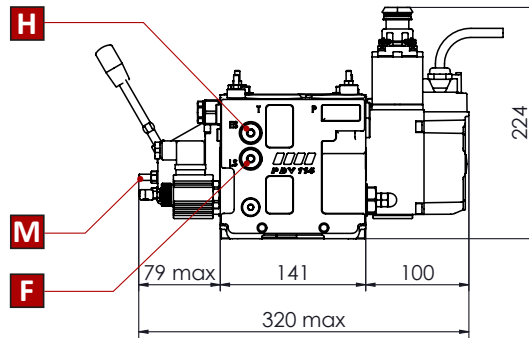
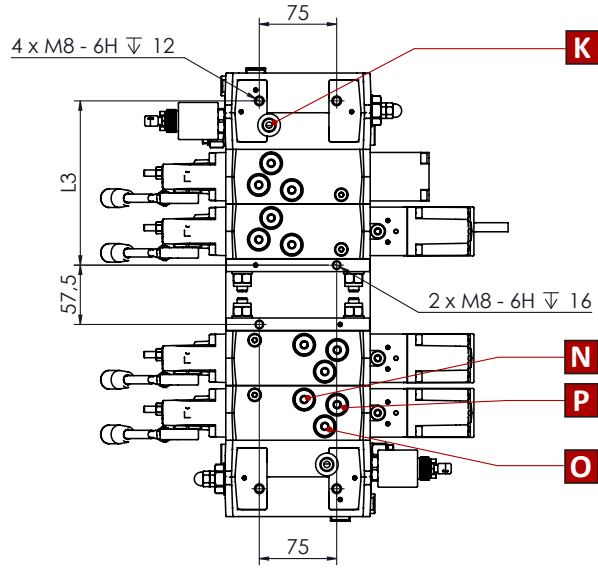

PDW		2	3	4	5	6	7	8	9	10	11	12
L1	mm	331	379	427	475	523	571	619	667	715	763	811
	in	13,03	14,92	16,81	18,70	20,59	22,48	24,37	26,26	28,15	30,04	31,93
L2	mm	351	399	447	495	543	591	639	687	735	783	831
	in	13,82	15,71	17,60	19,49	21,38	23,27	25,16	27,05	28,94	30,83	32,72

- A** = Pump side port - 3/4" BSPP - 17 mm deep [1 1/16 in 12 UN-2B - 0,67 in deep]
- B** = T port - 3/4" BSPP - 17 mm deep [1 1/16 in 12 UN - 2B - 0,67 in deep]
- C** = Main pressure relief valve
- D** = Main pressure reducing valve
- E** = Pump pressure gauge connection - 1/4" BSPP - 12 mm deep [7/16 in-20 UNF-2B - 0,47 in deep]
- F** = LS connection 1/4" BSPP - 12 mm deep [7/16 in-20 UNF-2B - 0,47 in deep]
- G** = External pilot pressure supply connection 1/4" BSPP - 12 mm deep [7/16 in-20 UNF-2B - 0,47 in deep]
- H** = External feeding main pressure reducing valve 1/4" BSPP - 12 mm deep [7/16 in-20 UNF-2B - 0,47 in deep]
- I** = Tank pressure gauge connection 1/4" BSPP - 12 mm deep [7/16 in-20 UNF-2B - 0,47 in deep]
- J** = Electrical LS/pump unloading function
- K** = Pump unloading drain port, 1/4" BSPP - 12 mm deep [7/16 in-20 UNF - 2B - 0,47 in deep]
- L** = Pump unloading mechanical override
- M** = A-B port mechanical flow adjustment
- N** = LSA
- O** = LSB } remote pilot pressure connection 1/4" BSPP - 12 mm deep [7/16 in-20 UNF - 2B - 0,47 in deep]
- P** = LS }
- Q** = Port A } 1/2" BSPP - 17 mm deep [7/8 in-14 UNF-2B - 0,67 in deep]
- R** = Port B }
- S** = LSB } pilot pressure relief valve
- T** = LSA }
- U** = Shock/suction valve B port
- V** = Shock/suction valve A port
- W** = External drain connection electric actuations - 1/4" BSPP - 12 mm deep [7/16 in-20 UNF-2B - 0,47 in deep]

PDV114 with double open centre inlet section (fixed displacement pump), pilot oil supply for electro-hydraulic spool actuations

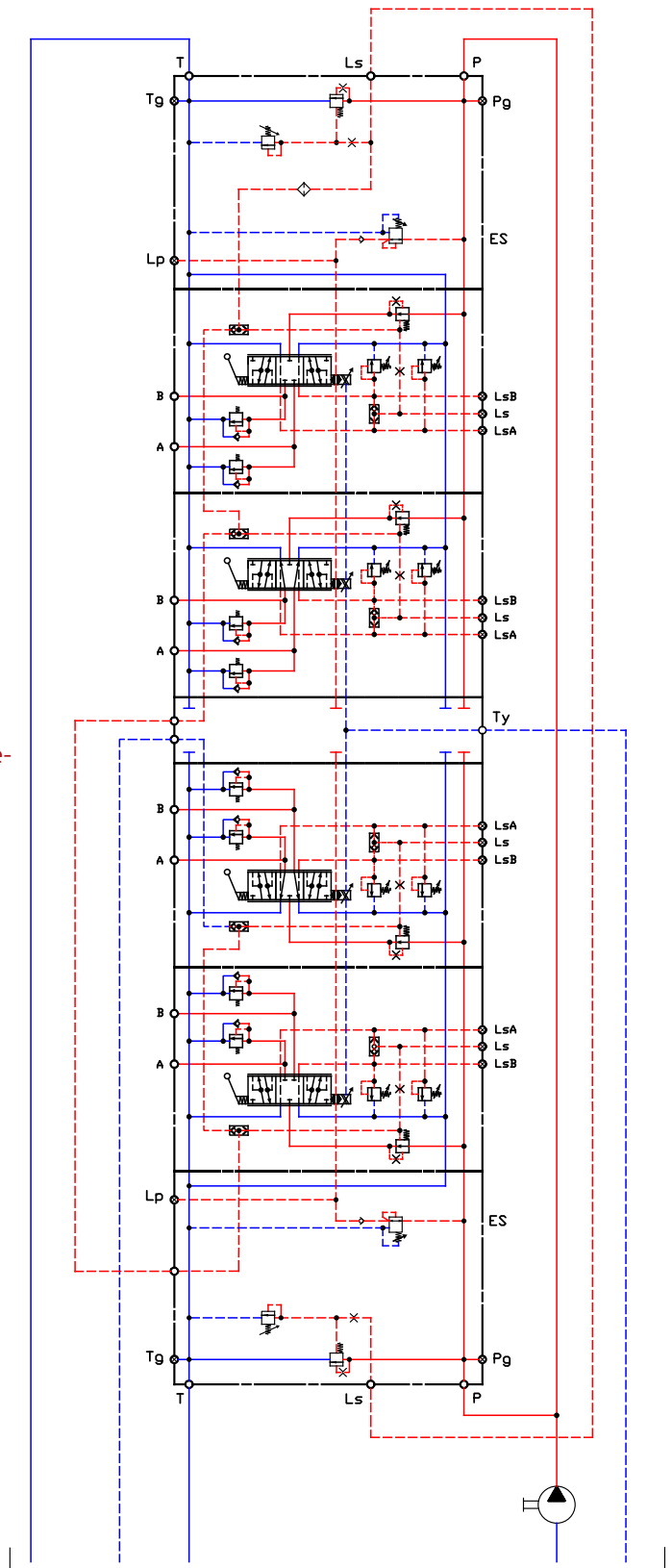

PDV114 Proportional valve
Hydraulic diagram

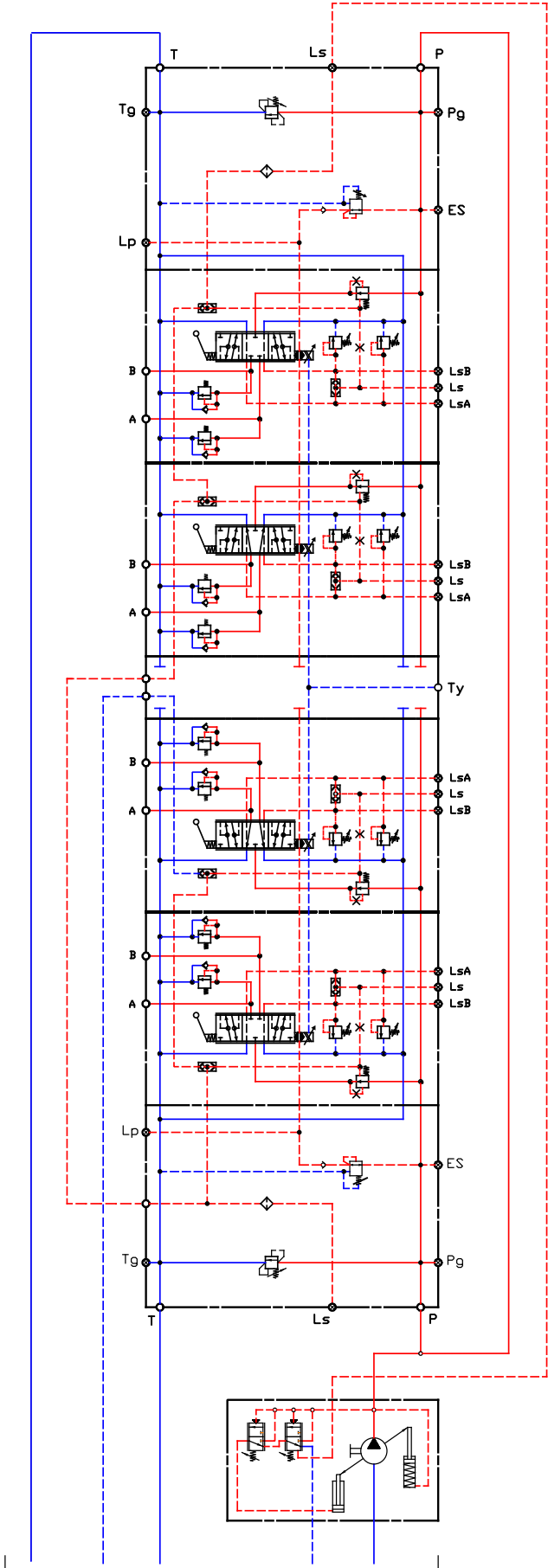

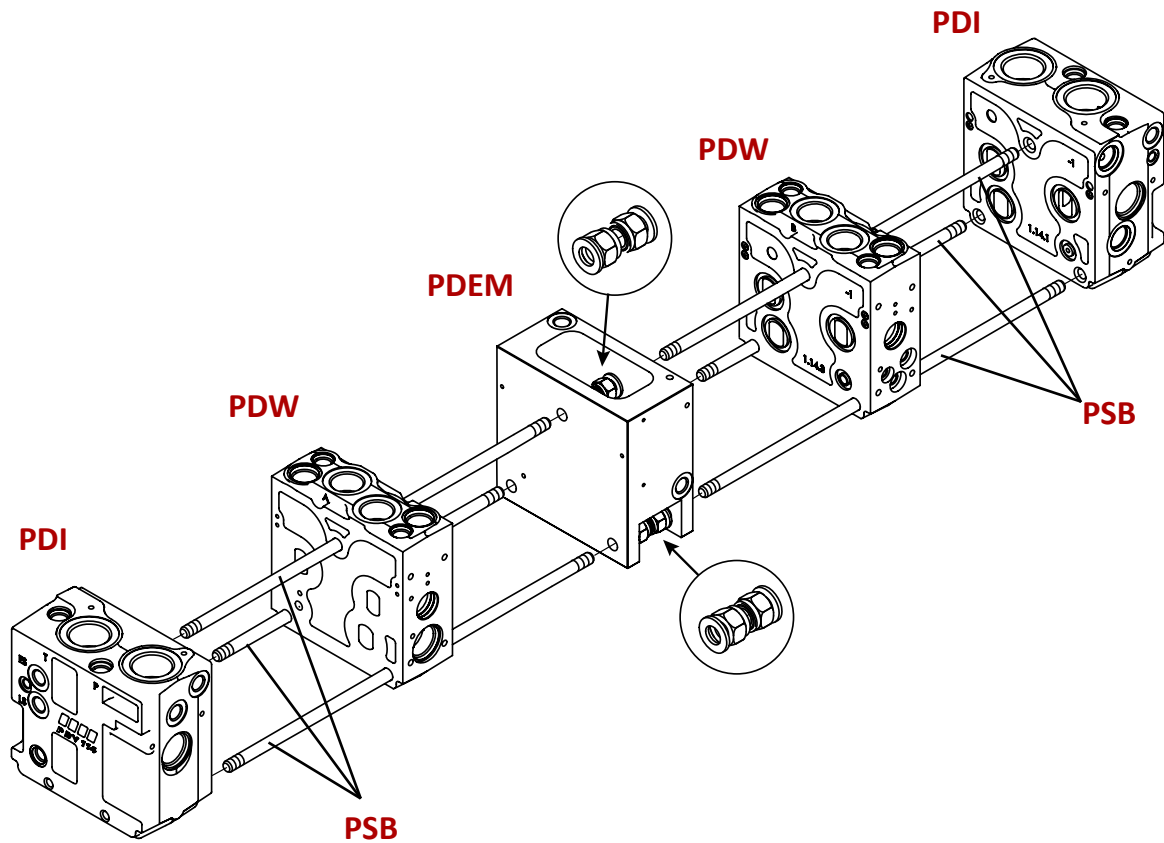

PDW	Code numbers	Tightening torque
1	PSB12010000	25 ± 2 Nm 220 ± 18 lb*in
2	PSB12020000	
3	PSB12030000	
4	PSB12040000	
5	PSB12050000	
6	PSB12060000	

PDV114 Proportional valve
Overall dimensions drawing with closed centre MID inlet section

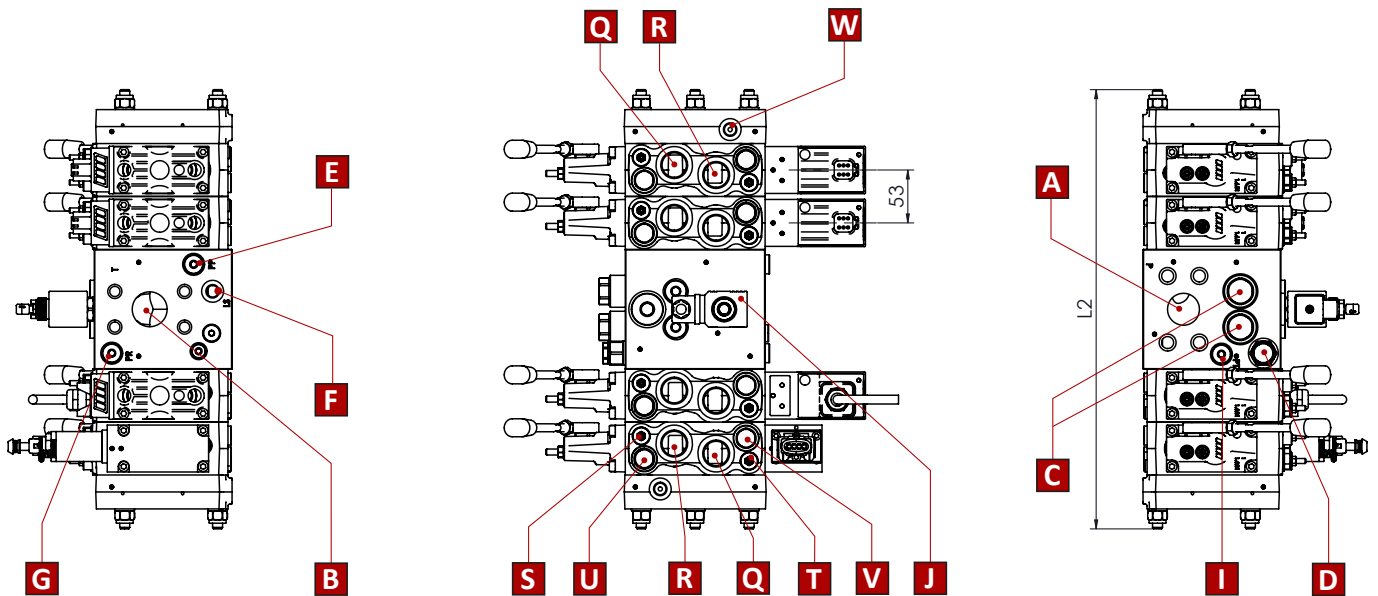
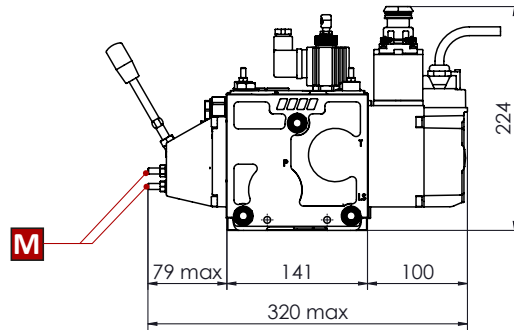
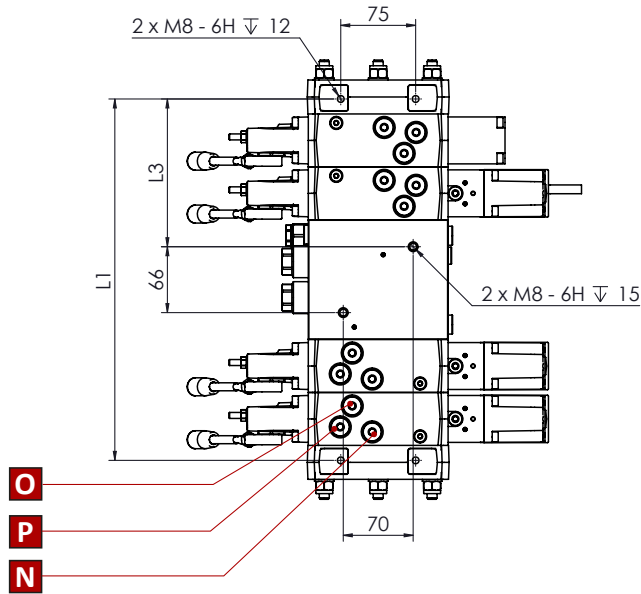

- A** = Pump side port - 3/4" BSPP - 17 mm deep [1 1/16 in 12 UN-2B - 0,67 in deep]
- B** = T port - 3/4" BSPP - 17 mm deep [1 1/16 in 12 UN - 2B - 0,67 in deep]
- C** = Main pressure relief valve
- D** = Main pressure reducing valve
- E** = Pump pressure gauge connection - 1/4" BSPP - 12 mm deep [7/16 in-20 UNF-2B - 0,47 in deep]
- F** = LS connection 1/4" BSPP - 12 mm deep [7/16 in-20 UNF-2B - 0,47 in deep]
- G** = External pilot pressure supply connection 1/4" BSPP - 12 mm deep [7/16 in-20 UNF-2B - 0,47 in deep]
- I** = Tank pressure gauge connection 1/4" BSPP - 12 mm deep [7/16 in-20 UNF-2B - 0,47 in deep]
- J** = Electrical LS/pump unloading function
- M** = Pump unloading drain port, 1/4" BSPP - 12 mm deep [7/16 in-20 UNF - 2B - 0,47 in deep]
- N** = LSA
- O** = LSB } remote pilot pressure connection 1/4" BSPP - 12 mm deep [7/16 in-20 UNF - 2B - 0,47 in deep]
- P** = LS
- Q** = Port A } 1/2" BSPP - 17 mm deep [7/8 in-14 UNF-2B - 0,67 in deep]
- R** = Port B
- S** = LS_B } pilot pressure relief valve
- T** = LS_A
- U** = Shock/suction valve B port
- V** = Shock/suction valve A port
- W** = External drain connection electric actuations - 1/4" BSPP - 12 mm deep [7/16 in-20 UNF-2B - 0,47 in deep]

PDV74 with MID-inlet closed centre section
(variable displacement pump), pilot oil supply for
electro-hydraulic spool actuations

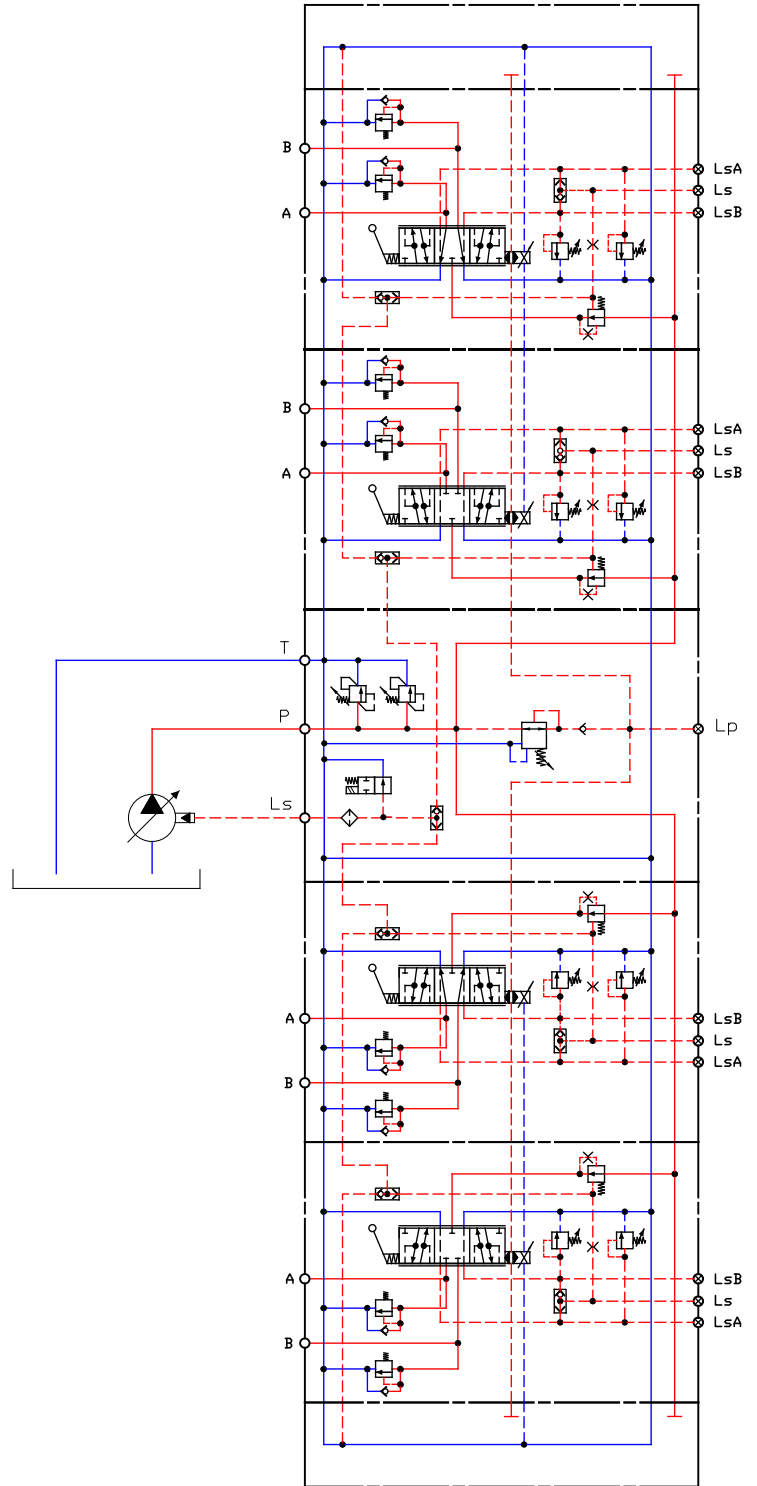

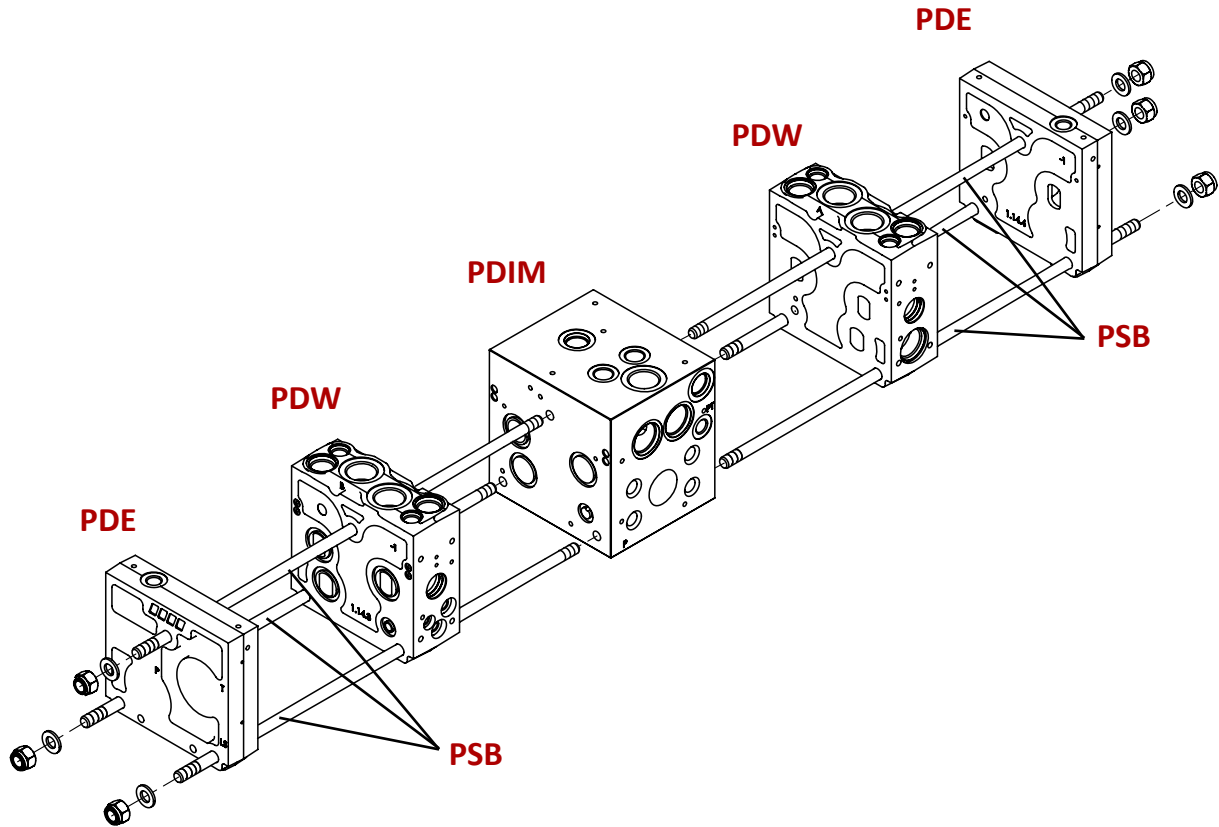

PDW	Code numbers	Tightening torque
1	PSB10010000	25 ± 2 Nm 220 ± 18 lb*in
2	PSB10020000	
3	PSB10030000	
4	PSB10040000	
5	PSB10050000	
6	PSB10060000	

PDV114 + PDV74 Proportional valve
Overall dimensions drawing with standard inlet section
Right assembly version

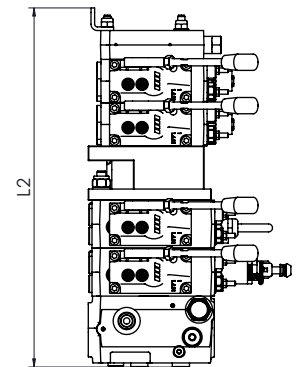
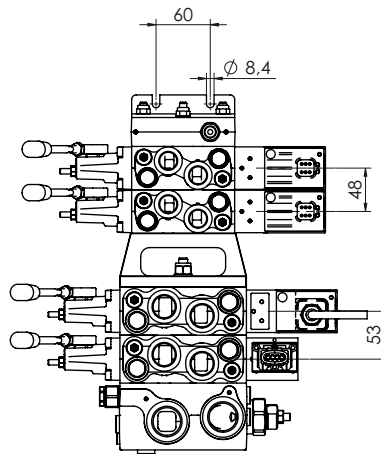
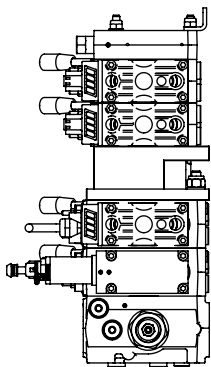
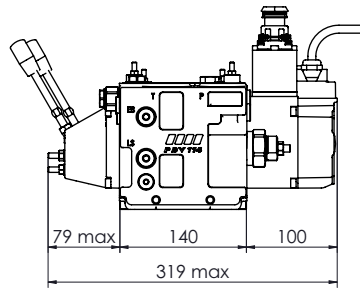
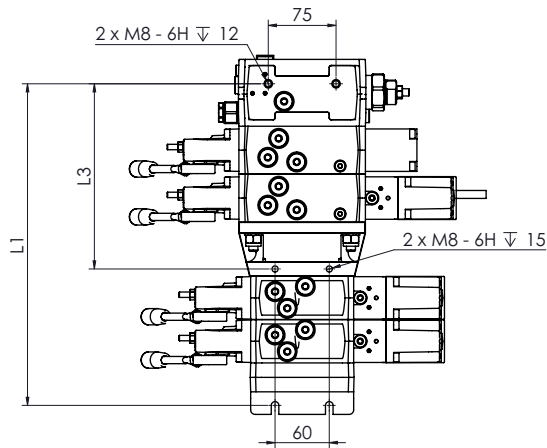

PDW		1	2	3	4	5	6	7	8	9	10	11	12
L1	mm	180	228	276	324	372	420	468	516	564	612	660	708
	in	7,09	8,98	10,87	12,76	14,65	16,54	18,43	20,31	22,20	24,09	25,98	27,87
L2	mm	200	248	296	344	392	440	488	536	584	632	680	728
	in	7,87	9,76	11,65	13,54	15,43	17,32	19,21	21,10	22,99	24,88	26,77	28,66

- A** = Pump side port - 3/4" BSPP - 17 mm deep [1 1/16 in 12 UN-2B - 0,67 in deep]
B = T port - 3/4" BSPP - 17 mm deep [1 1/16 in 12 UN - 2B - 0,67 in deep]
C = Main pressure relief valve
D = Main pressure reducing valve
E = Pump pressure gauge connection - 1/4" BSPP - 12 mm deep [7/16 in-20 UNF-2B - 0,47 in deep]
F = LS connection 1/4" BSPP - 12 mm deep [7/16 in-20 UNF-2B - 0,47 in deep]
G = External pilot pressure supply connection 1/4" BSPP - 12 mm deep [7/16 in-20 UNF-2B - 0,47 in deep]
H = External feeding main pressure reducing valve 1/4" BSPP - 12 mm deep [7/16 in-20 UNF-2B - 0,47 in deep]
I = Tank pressure gauge connection 1/4" BSPP - 12 mm deep [7/16 in-20 UNF-2B - 0,47 in deep]
J = Electrical LS/pump unloading function
K = Pump unloading drain port, 1/4" BSPP - 12 mm deep [7/16 in-20 UNF - 2B - 0,47 in deep]
L = Pump unloading mechanical override
M = A-B port mechanical flow adjustment
N = LSA
O = LSB } remote pilot pressure connection 1/4" BSPP - 12 mm deep [7/16 in-20 UNF - 2B - 0,47 in deep]
P = LS }
Q = Port A } 1/2" BSPP - 17 mm deep [7/8 in-14 UNF-2B - 0,67 in deep]
R = Port B }
S = LSB } pilot pressure relief valve
T = LSA }
U = Shock/suction valve B port
V = Shock/suction valve A port
W = External drain connection electric actuations - 1/4" BSPP - 12 mm deep [7/16 in-20 UNF-2B - 0,47 in deep]

PDV117 with open centre inlet section (fixed displacement pump),
pump unloading system, pilot oil supply for electro-hydraulic
spool actuations

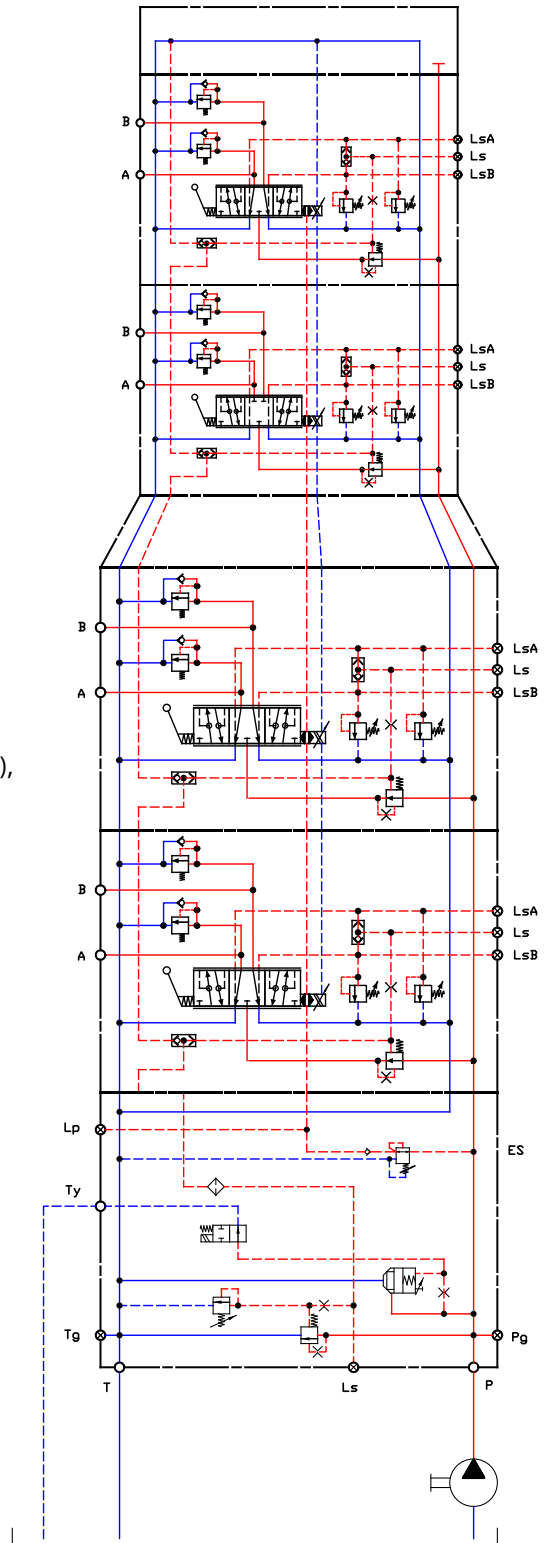

PDV117 with closed centre inlet section (variable displacement pump), pilot oil supply for electro-hydraulic spool actuations

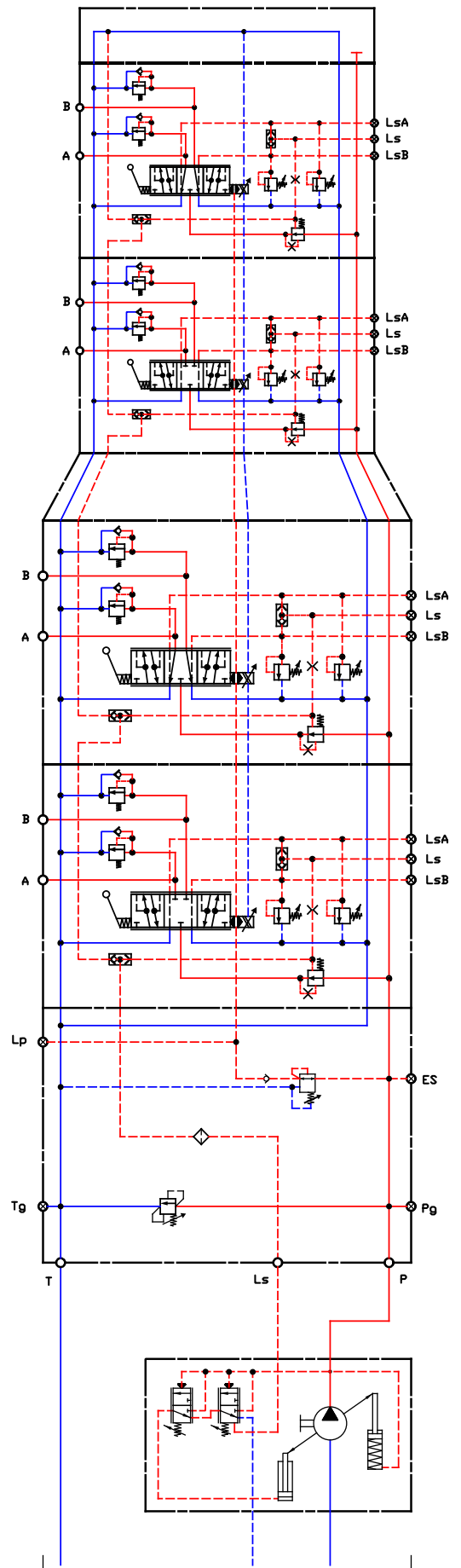

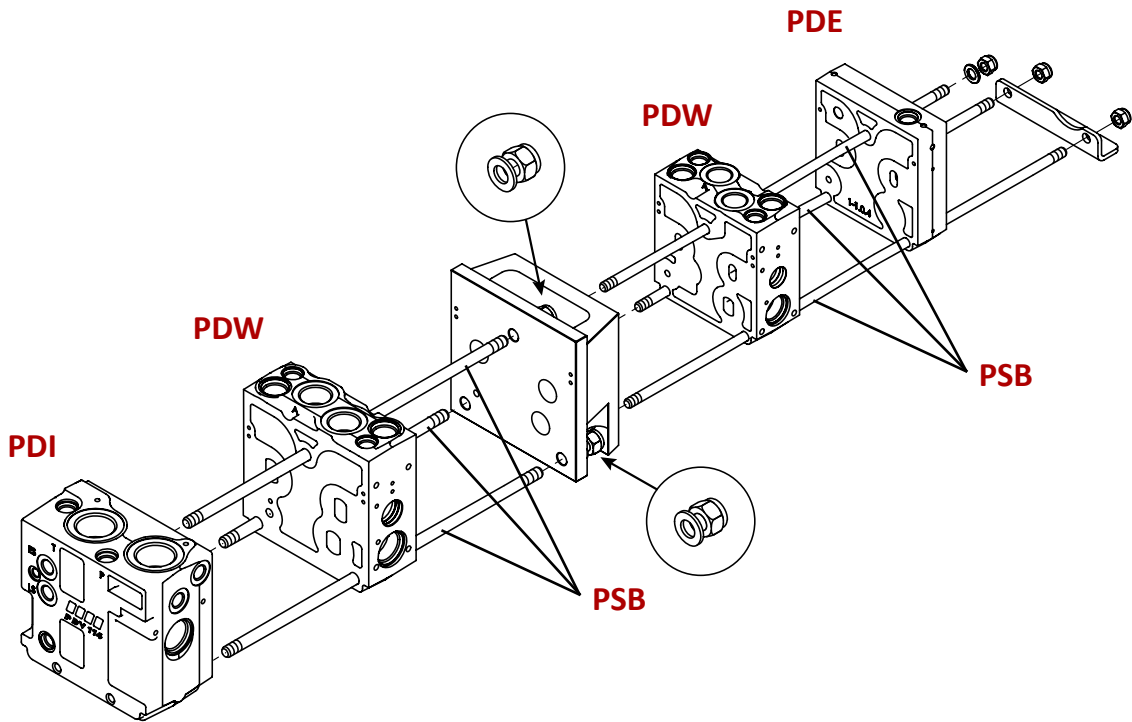

PDW	Code numbers PDV114	Code numbers PDV74	Tightening torque
1	PSB12010000	PSB70011000	<p style="text-align: center;">25 ± 2 Nm 220 ± 18 lb*in</p>
2	PSB12020000	PSB70021000	
3	PSB12030000	PSB70031000	
4	PSB12040000	PSB70041000	
5	PSB12050000	PSB70051000	
6	PSB12060000	PSB70061000	
7	PSB12070000	PSB70071000	
8	PSB12080000	PSB70081000	

PDV114 + PDV74 Proportional valve
Overall dimensions drawing with double inlet
and MID end section

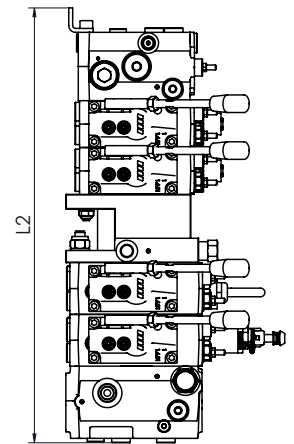
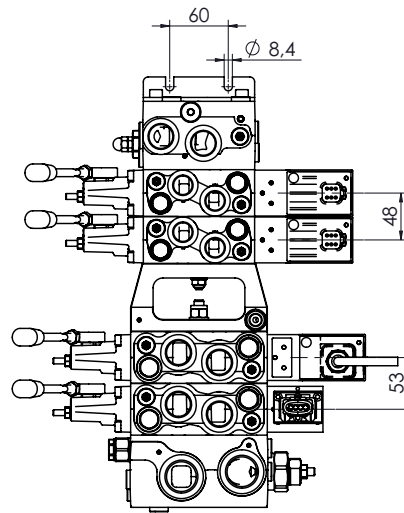
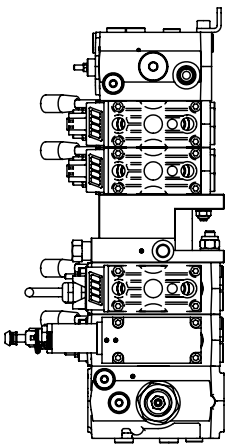
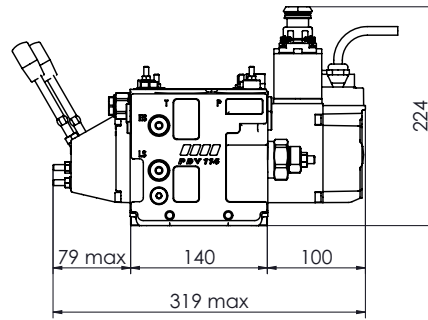
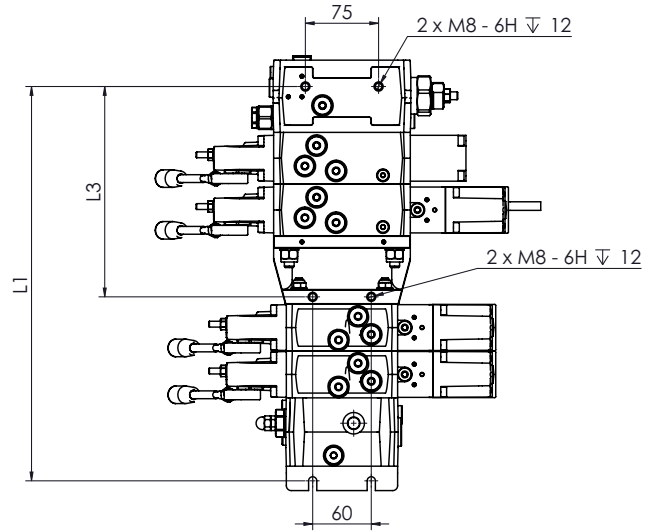

- A** = Pump side port - 3/4" BSPP - 17 mm deep [1 1/16 in 12 UN-2B - 0,67 in deep]
B = T port - 3/4" BSPP - 17 mm deep [1 1/16 in 12 UN - 2B - 0,67 in deep]
C = Main pressure relief valve
D = Main pressure reducing valve
E = Pump pressure gauge connection - 1/4" BSPP - 12 mm deep [7/16 in-20 UNF-2B - 0,47 in deep]
F = LS connection 1/4" BSPP - 12 mm deep [7/16 in-20 UNF-2B - 0,47 in deep]
G = External pilot pressure supply connection 1/4" BSPP - 12 mm deep [7/16 in-20 UNF-2B - 0,47 in deep]
H = External feeding main pressure reducing valve 1/4" BSPP - 12 mm deep [7/16 in-20 UNF-2B - 0,47 in deep]
I = Tank pressure gauge connection 1/4" BSPP - 12 mm deep [7/16 in-20 UNF-2B - 0,47 in deep]
J = Electrical LS/pump unloading function
K = Pump unloading drain port, 1/4" BSPP - 12 mm deep [7/16 in-20 UNF - 2B - 0,47 in deep]
L = Pump unloading mechanical override
M = A-B port mechanical flow adjustment
N = LSA
O = LSB } remote pilot pressure connection 1/4" BSPP - 12 mm deep [7/16 in-20 UNF - 2B - 0,47 in deep]
P = LS }
Q = Port A } 1/2" BSPP - 17 mm deep [7/8 in-14 UNF-2B - 0,67 in deep]
R = Port B }
S = LSB } pilot pressure relief valve
T = LSA }
U = Shock/suction valve B port
V = Shock/suction valve A port
W = External drain connection electric actuations - 1/4" BSPP - 12 mm deep [7/16 in-20 UNF-2B - 0,47 in deep]

PDV117 with double open centre inlet section (fixed displacement pump), pilot oil supply for electro-hydraulic spool actuations

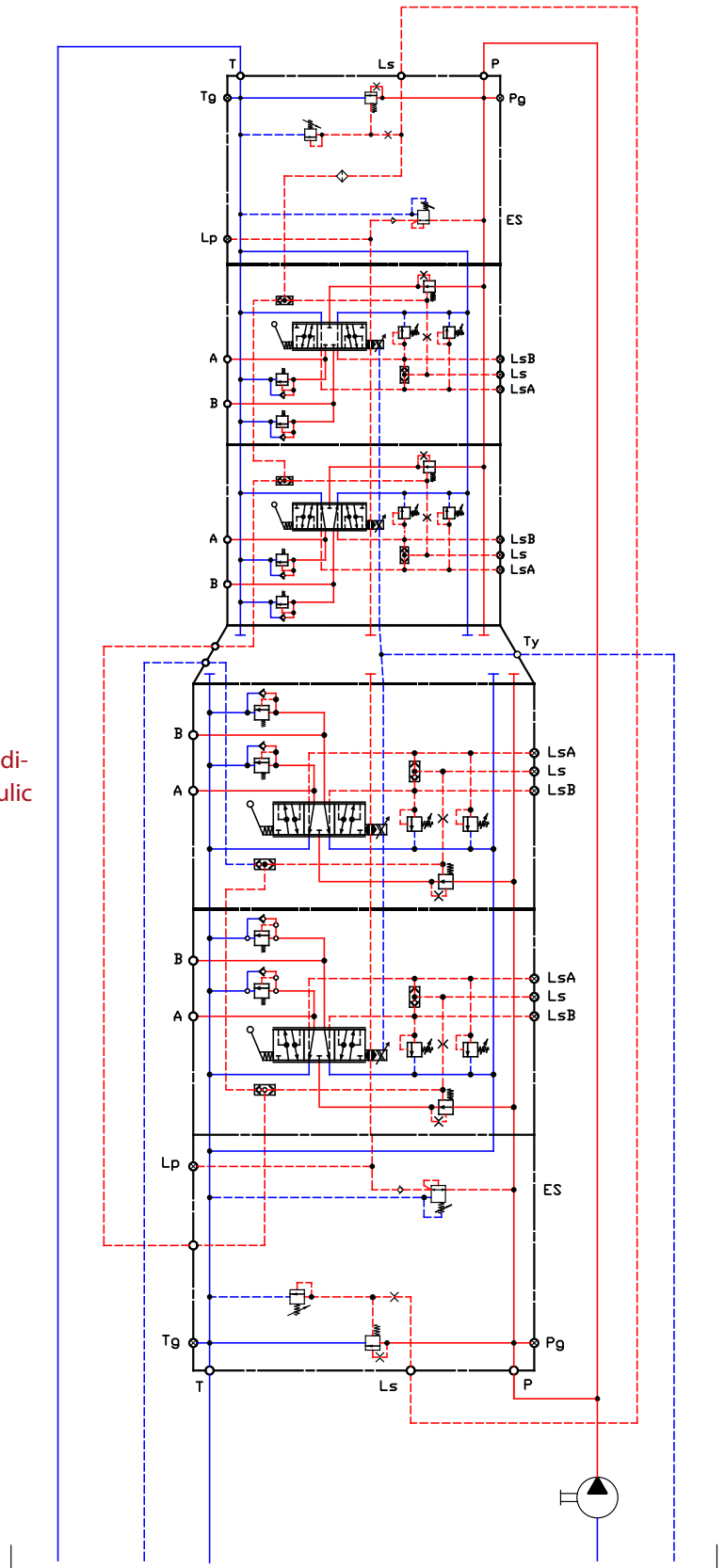

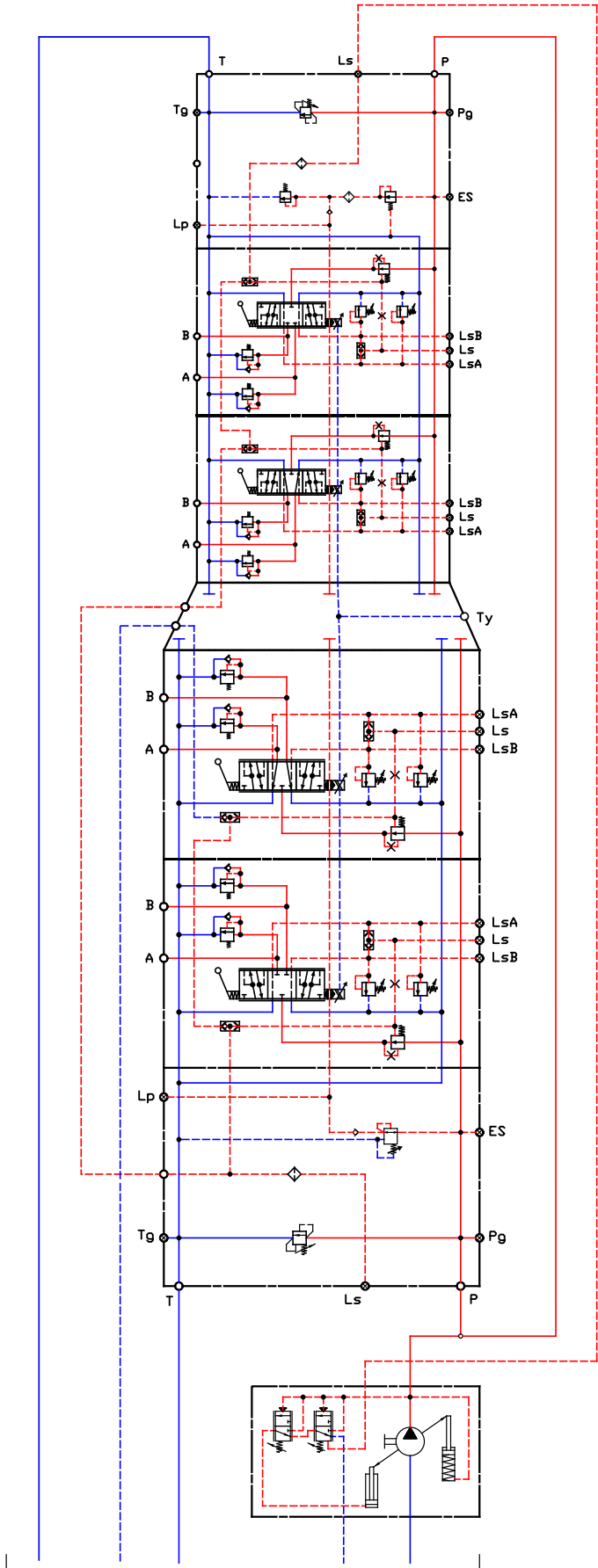

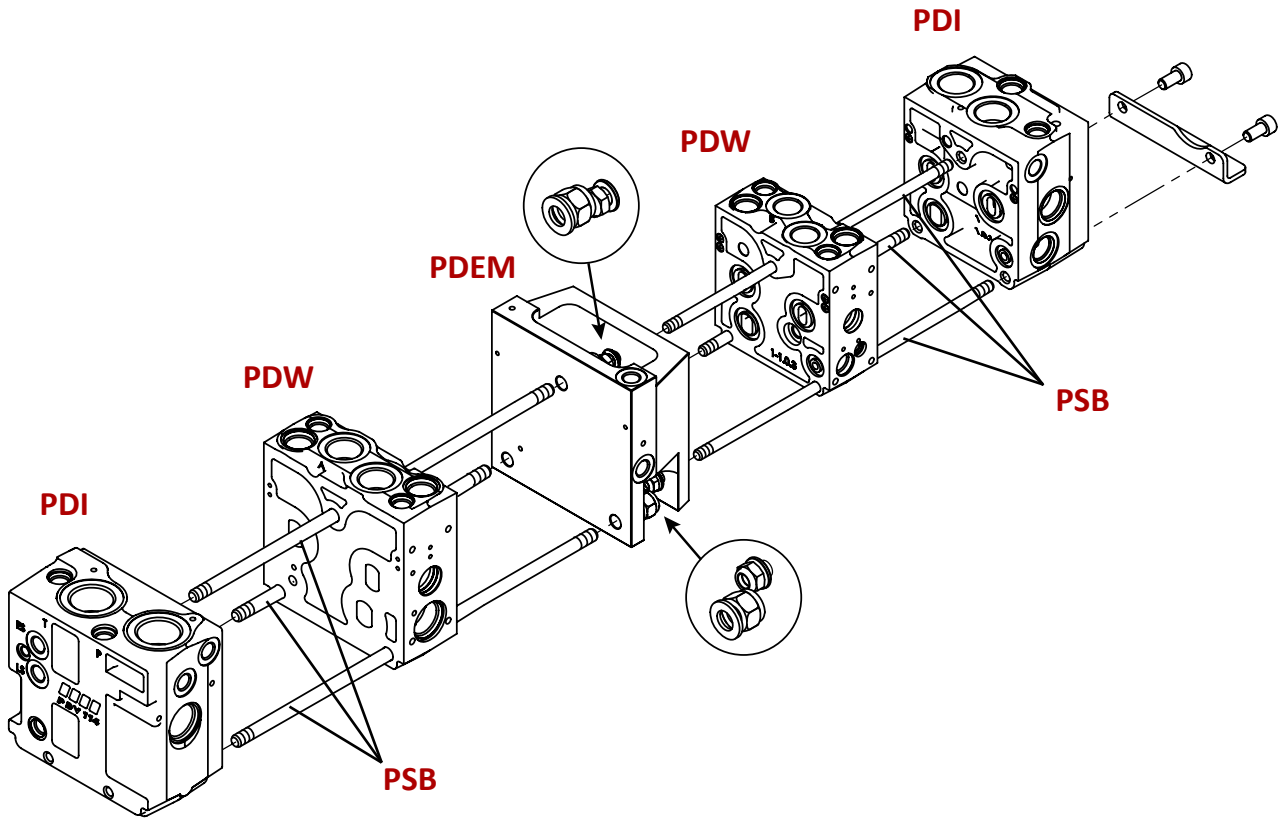

PDW	Code numbers PDV114	Code numbers PDV74	Tightening torque
1	PSB12010000	PSB72011000	<p>25 ± 2 Nm 220 ± 18 lb*in</p>
2	PSB12020000	PSB72021000	
3	PSB12030000	PSB72031000	
4	PSB12040000	PSB72041000	
5	PSB12050000	PSB72051000	
6	PSB12060000	PSB72061000	

PDV114 + PDV74 Proportional valve
Overall dimensions drawing with closed centre MID inlet section

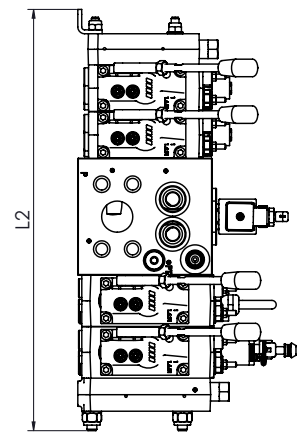
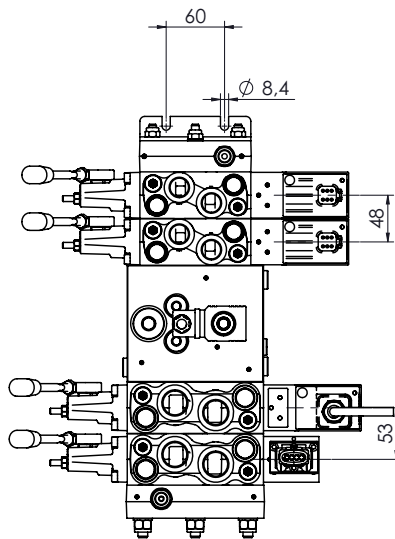
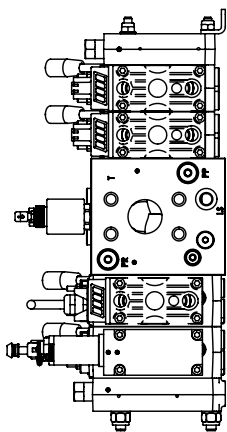
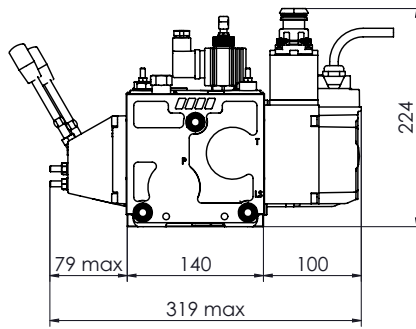
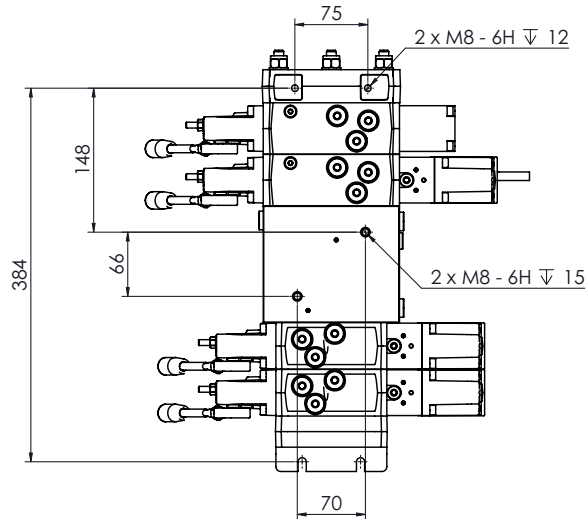

- A** = Pump side port - 3/4" BSPP - 17 mm deep [1 1/16 in 12 UN-2B - 0,67 in deep]
 - B** = T port - 3/4" BSPP - 17 mm deep [1 1/16 in 12 UN - 2B - 0,67 in deep]
 - C** = Main pressure relief valve
 - D** = Main pressure reducing valve
 - E** = Pump pressure gauge connection - 1/4" BSPP - 12 mm deep [7/16 in-20 UNF-2B - 0,47 in deep]
 - F** = LS connection 1/4" BSPP - 12 mm deep [7/16 in-20 UNF-2B - 0,47 in deep]
 - G** = External pilot pressure supply connection 1/4" BSPP - 12 mm deep [7/16 in-20 UNF-2B - 0,47 in deep]
 - H** = External feeding main pressure reducing valve 1/4" BSPP - 12 mm deep [7/16 in-20 UNF-2B - 0,47 in deep]
 - I** = Tank pressure gauge connection 1/4" BSPP - 12 mm deep [7/16 in-20 UNF-2B - 0,47 in deep]
 - J** = Electrical LS/pump unloading function
 - K** = Pump unloading drain port, 1/4" BSPP - 12 mm deep [7/16 in-20 UNF - 2B - 0,47 in deep]
 - L** = Pump unloading mechanical override
 - M** = A-B port mechanical flow adjustment
 - N** = LSA
 - O** = LSB
 - P** = LS
 - Q** = Port A
 - R** = Port B
 - S** = LSB
 - T** = LSA
 - U** = Shock/suction valve B port
 - V** = Shock/suction valve A port
 - W** = External drain connection electric actuations - 1/4" BSPP - 12 mm deep [7/16 in-20 UNF-2B - 0,47 in deep]
- } remote pilot pressure connection 1/4" BSPP - 12 mm deep [7/16 in-20 UNF - 2B - 0,47 in deep]
 } 1/2" BSPP - 17 mm deep [7/8 in-14 UNF-2B - 0,67 in deep]
 } pilot pressure relief valve

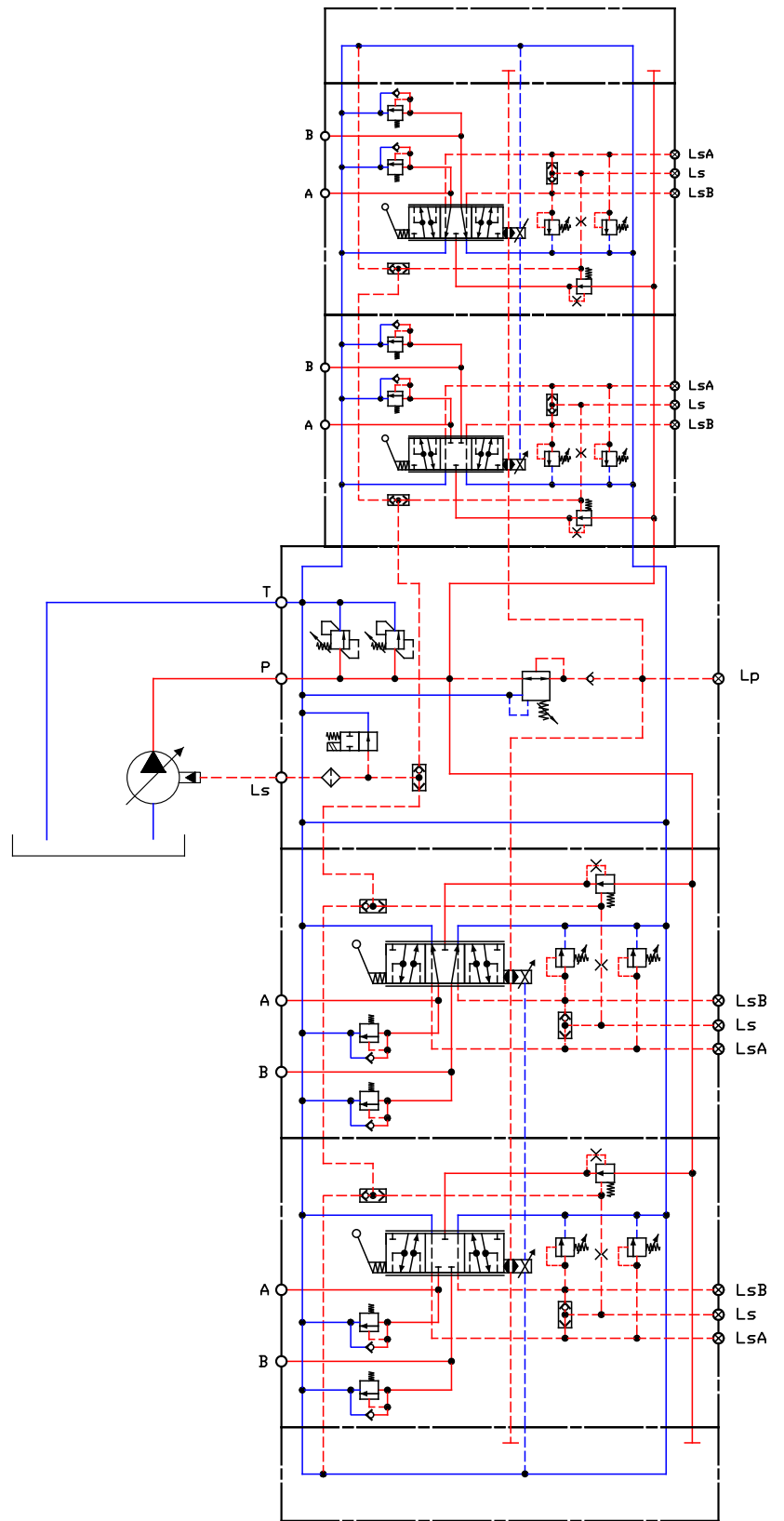

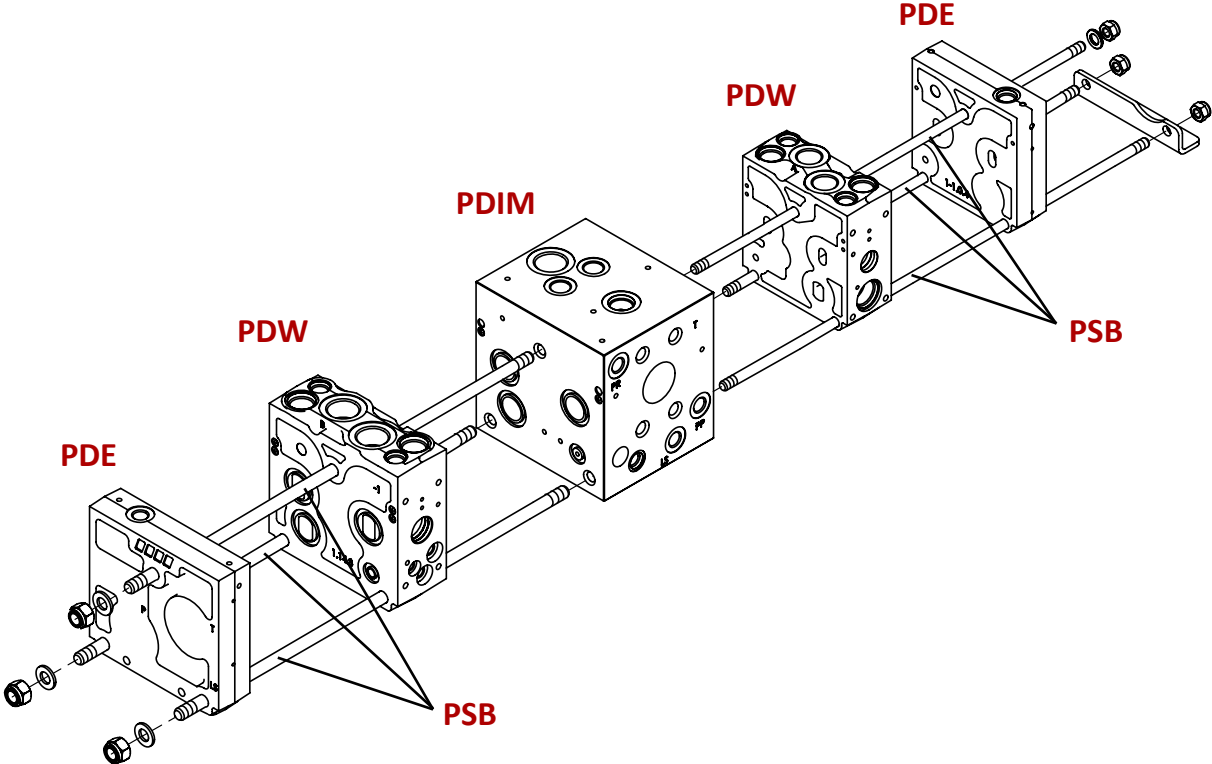

PDW	Code numbers PDV114	Code numbers PDV74	Tightening torque
1	PSB10010000	PSB71011000	25 ± 2 Nm 220 ± 18 lb*in
2	PSB10020000	PSB71021000	
3	PSB10030000	PSB71031000	
4	PSB10040000	PSB71041000	
5	PSB10050000	PSB71051000	
6	PSB10060000	PSB71061000	

PDV114 Proportional valve
Right side version

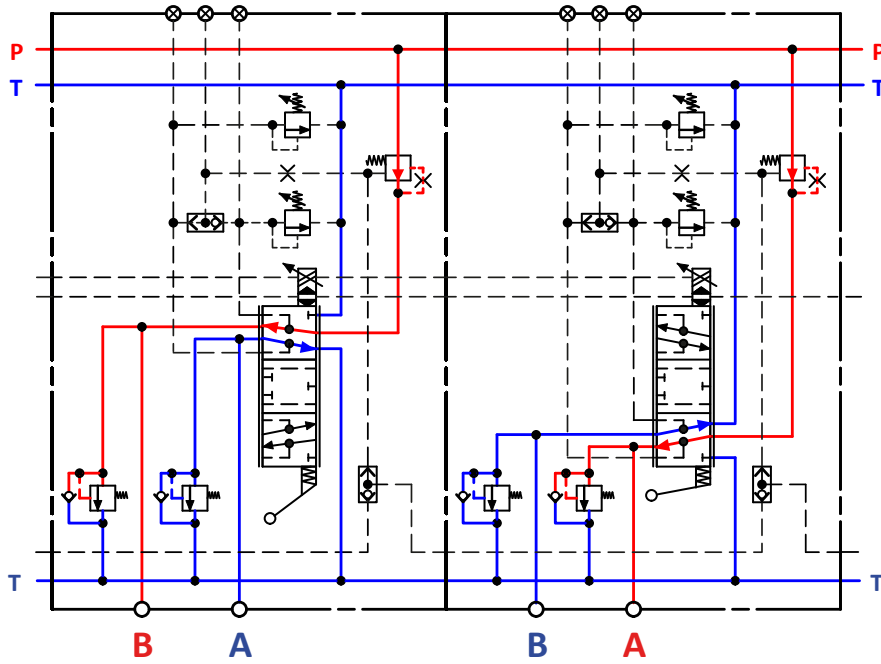
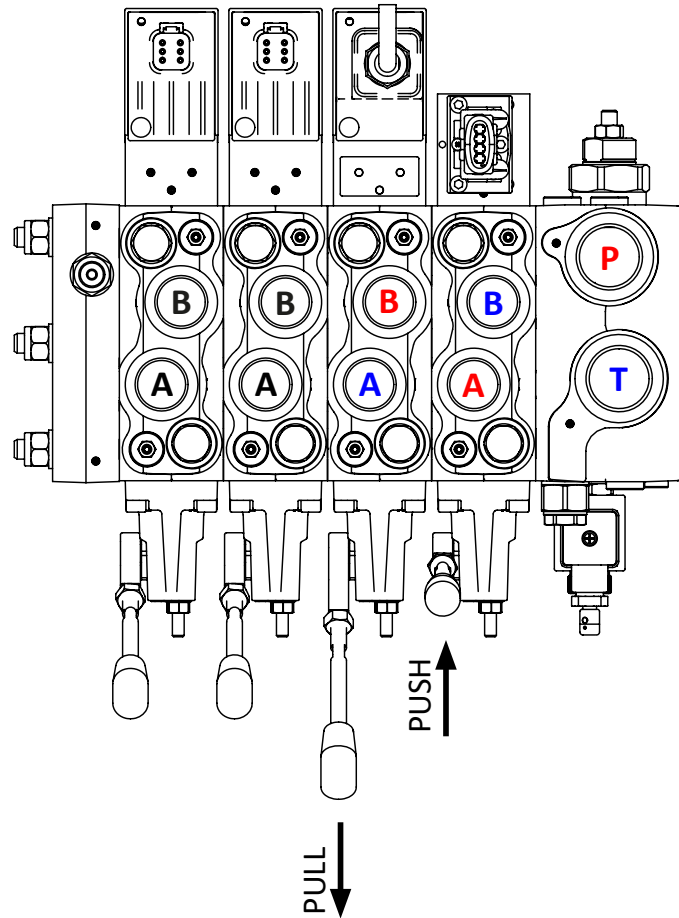

PDV114 Proportional valve
Left side version

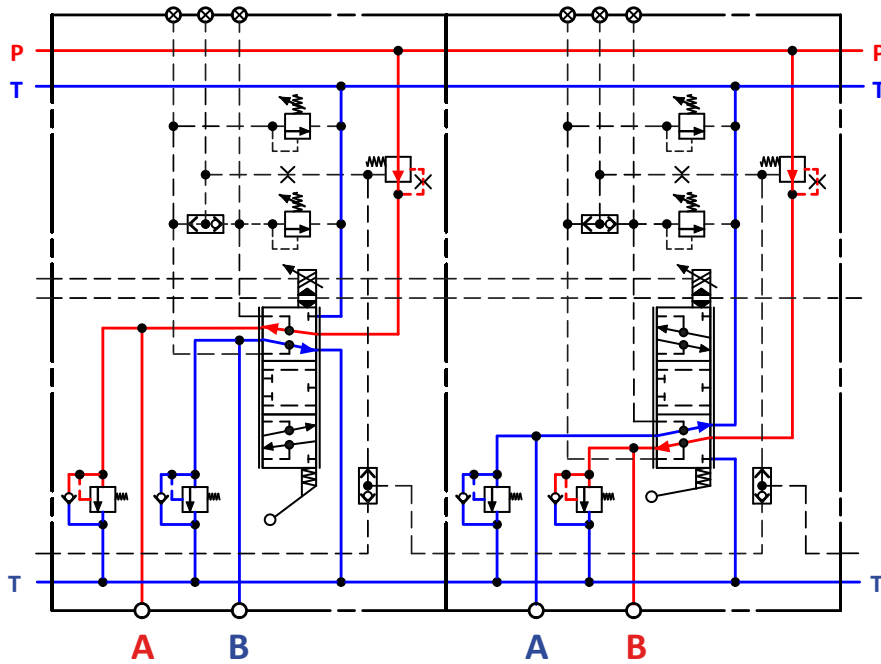
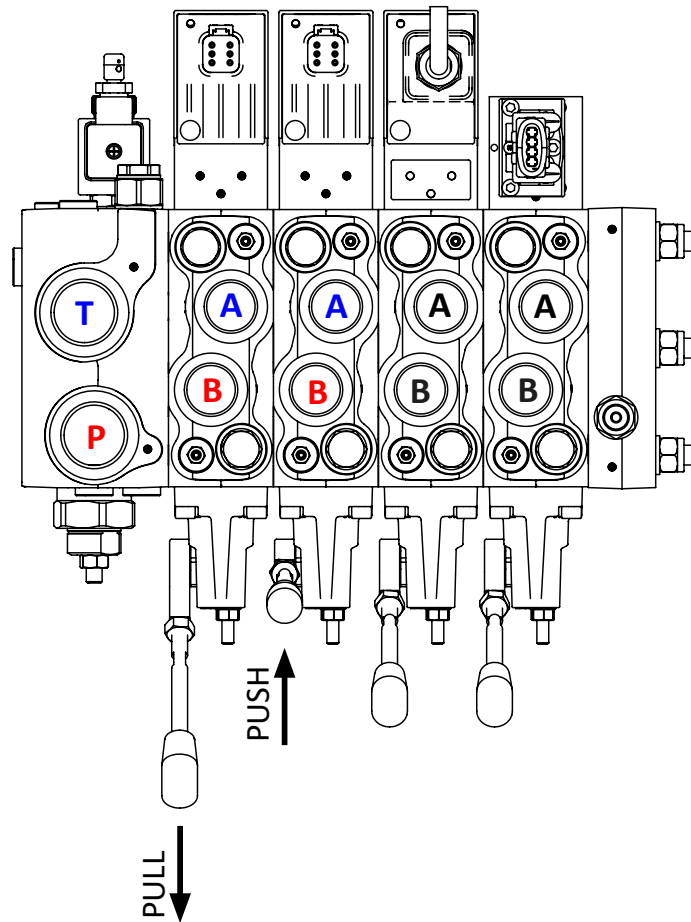

PDV114 Proportional valve Configuration with standard inlet section - Right side assembly Product selection chart

This specification sheet, gives an overview of any modules with which the PDV74 is being assembled. Each module has its own field. The purpose of this chart is to provide a quick access to the module's choice, whose characteristics must always be checked on the catalog related data.

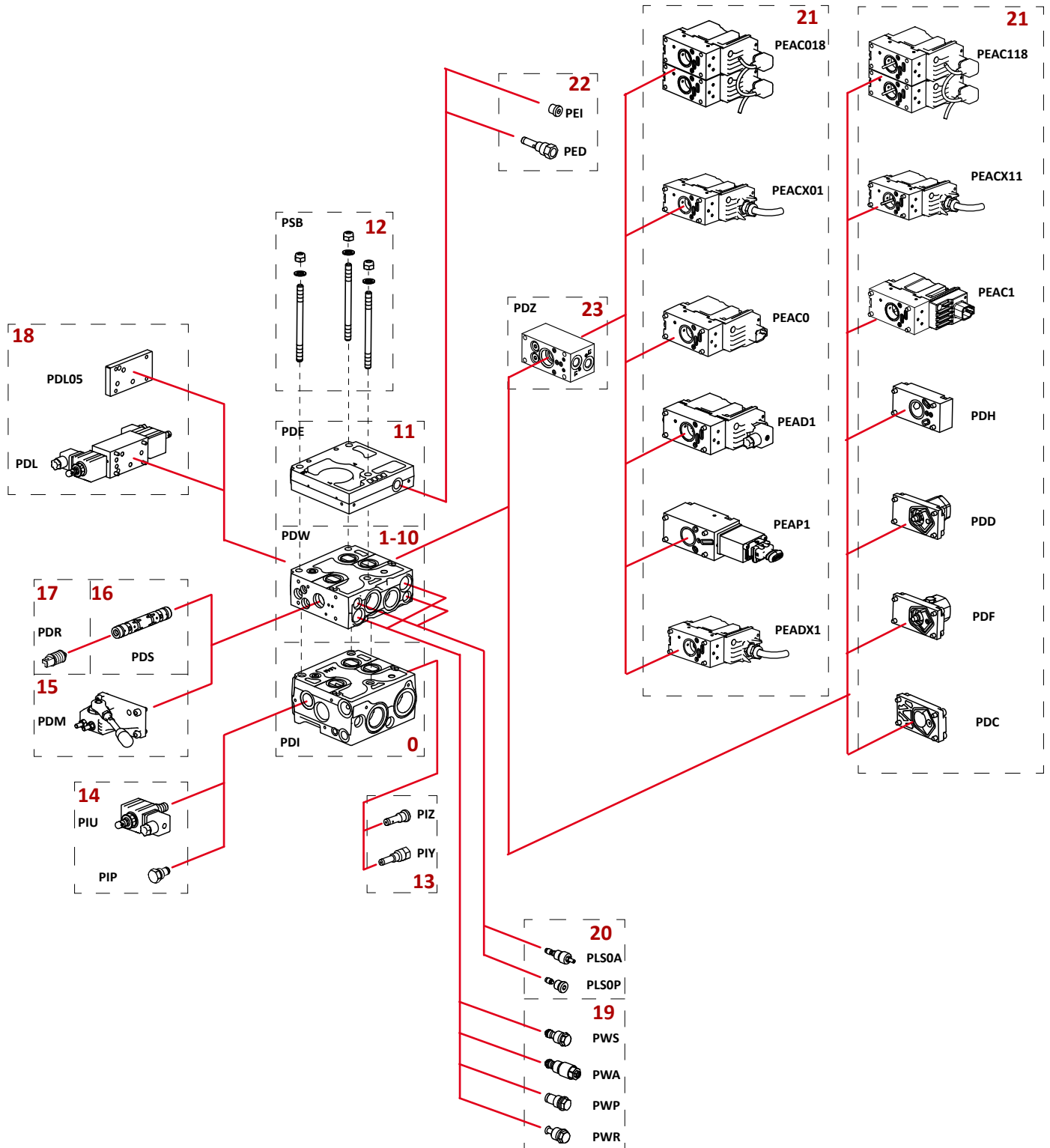

Reference field	Description		Code numbers see pag
0	Inlet sections	Open centre	PDI 155 - 156
		Closed centre	157 - 158
1-10	Working sections	with pressure compensator	PDW 161 - 162
		without pressure compensator	163 - 164
11	End sections		PDE 165 - 166
12	Stay bolt set		PSB 252
13	Pilot oil supply cartridge	Internal	PIZ 182
		External	PIY 182
14	Solenoid Ls unloading		PIU 159 - 160
	Plug for LS unloading cavity		PIP 159
15	Mechanical actuation		PDM 179
16	Spool		PDS From 170 to 178
17	Spool centered set		PDR From 172 to 178
18	Unloading module		PDL From 186 to 190
	Cover plate		PDL05
19	Shock and suction valve	not adjustable	PWS 183-184
		adjustable	PWA 183-184
	Plug for shock and suction valve cavity		PWP 185
	Suction valve		PWR 185
20	Pilot pressure LS _{A/B} relief valve		PLS0A 180
	Set plug LS _{A/B} cavity		PLS0P 180
21	Proportional electro-hydraulic actuations	Open loop spool control current signal for PWM and ON-OFF control	PEAD1 From 236 to 241
		Open loop spool control high resolution	PEAC0 From 215 to 235
		Closed loop spool control high performance resolution	PEAC1 From 191 to 214
		Open loop spool control high resolution CAN-Bus	PEAC018
		Closed loop spool control high performance resolution CAN-Bus	PEAC118
		Open loop spool control high resolution ATEX	PEACX01
		Closed loop spool control high performance resolution ATEX version	PEACX11
		Open loop spool control current signal for PWM and ON-OFF control ATEX version	PEADX1
		Open loop spool control current input signal for PWM and ON-OFF control - AMP JPT 4 pin	PEAP1 From 242 to 247
	Rear cover for	Hydraulic control	PDH 180
		Detent	PDD 181
		Friction detent	PDF 179
Mechanical actuation		PDC 180	
22	End sections	External drain line cartridge	PED 182
		Internal plug	PEI 182
23	Dual function control body		PDZ 168 - 169
24	Pump pressure relief valve (for closed centre only)		PRV0A
	Plug for relief valve cavity (for closed centre only)		PRV0P

PDV114 Proportional valve, product selection chart Configuration with double inlet sections and MID end section

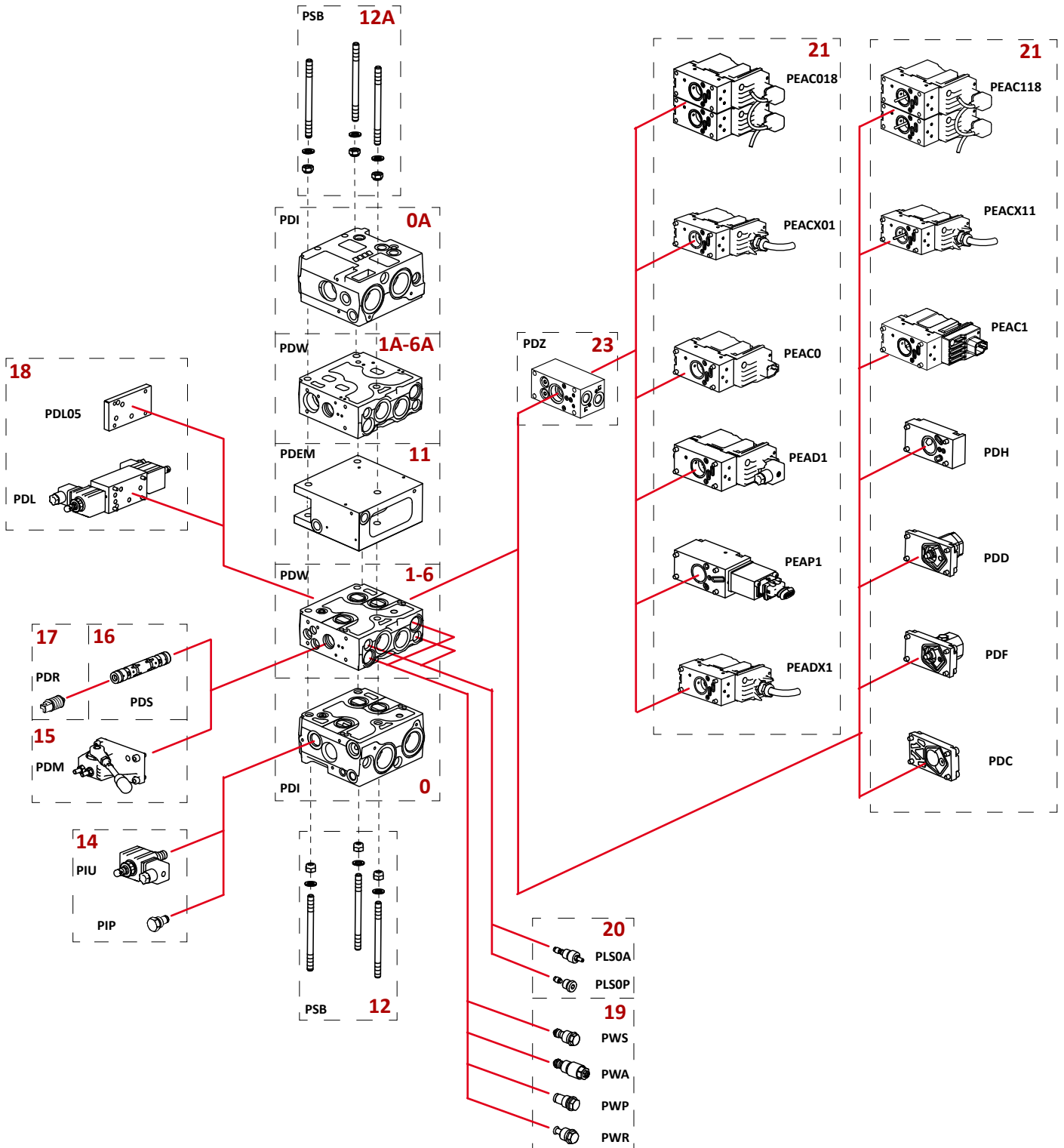

Reference field	Description			Code numbers see pag
0 0A	Inlet sections	Open centre	PDI	155 - 156
		Closed centre		157 - 158
1-6 1A-6A	Working sections	with pressure compensator	PDW	161 - 162
		without pressure compensator		163 - 164
11	End sections		PDE	165 - 166
12 12A	Stay bolt set		PSB	258
13	Pilot oil supply cartridge	Internal	PIZ	182
		External	PIY	182
14	Solenoid Ls unloading		PIU	159 - 160
	Plug for LS unloading cavity		PIP	159
15	Mechanical actuation		PDM	179
16	Spool		PDS	From 170 to 178
17	Spool centered set		PDR	From 172 to 178
18	Unloading module		PDL	From 186 to 190
	Cover plate		PDL05	
19	Shock and suction valve	not adjustable	PWS	183-184
		adjustable	PWA	183-184
	Plug for shock and suction valve cavity		PWP	185
	Suction valve		PWR	185
20	Pilot pressure LS _{A/B} relief valve		PLS0A	180
	Set plug LS _{A/B} cavity		PLS0P	180
21	Proportional electro-hydraulic actuations	Open loop spool control current signal for PWM and ON-OFF control	PEAD1	From 236 to 241
		Open loop spool control high resolution	PEAC0	From 215 to 235
		Closed loop spool control high performance resolution	PEAC1	From 191 to 214
		Open loop spool control high resolution CAN-Bus	PEAC018	
		Closed loop spool control high performance resolution CAN-Bus	PEAC118	
		Open loop spool control high resolution ATEX	PEACX01	
		Closed loop spool control high performance resolution ATEX version	PEACX11	
		Open loop spool control current signal for PWM and ON-OFF control ATEX version	PEADX1	
	Open loop spool control current input signal for PWM and ON-OFF control - AMP JPT 4 pin	PEAP1	From 242 to 247	
	Rear cover for	Hydraulic control	PDH	180
Detent		PDD	181	
Friction detent		PDF	179	
Mechanical actuation		PDC	180	
22	End sections	External drain line cartridge	PED	182
		Internal plug	PEI	182
23	Dual function control body		PDZ	168 - 169
24	Pump pressure relief valve (for closed centre only)		PRV0A	
	Plug for relief valve cavity (for closed centre only)		PRV0P	

PDV114 Proportional valve, product selection chart

Configuration with MID inlet section

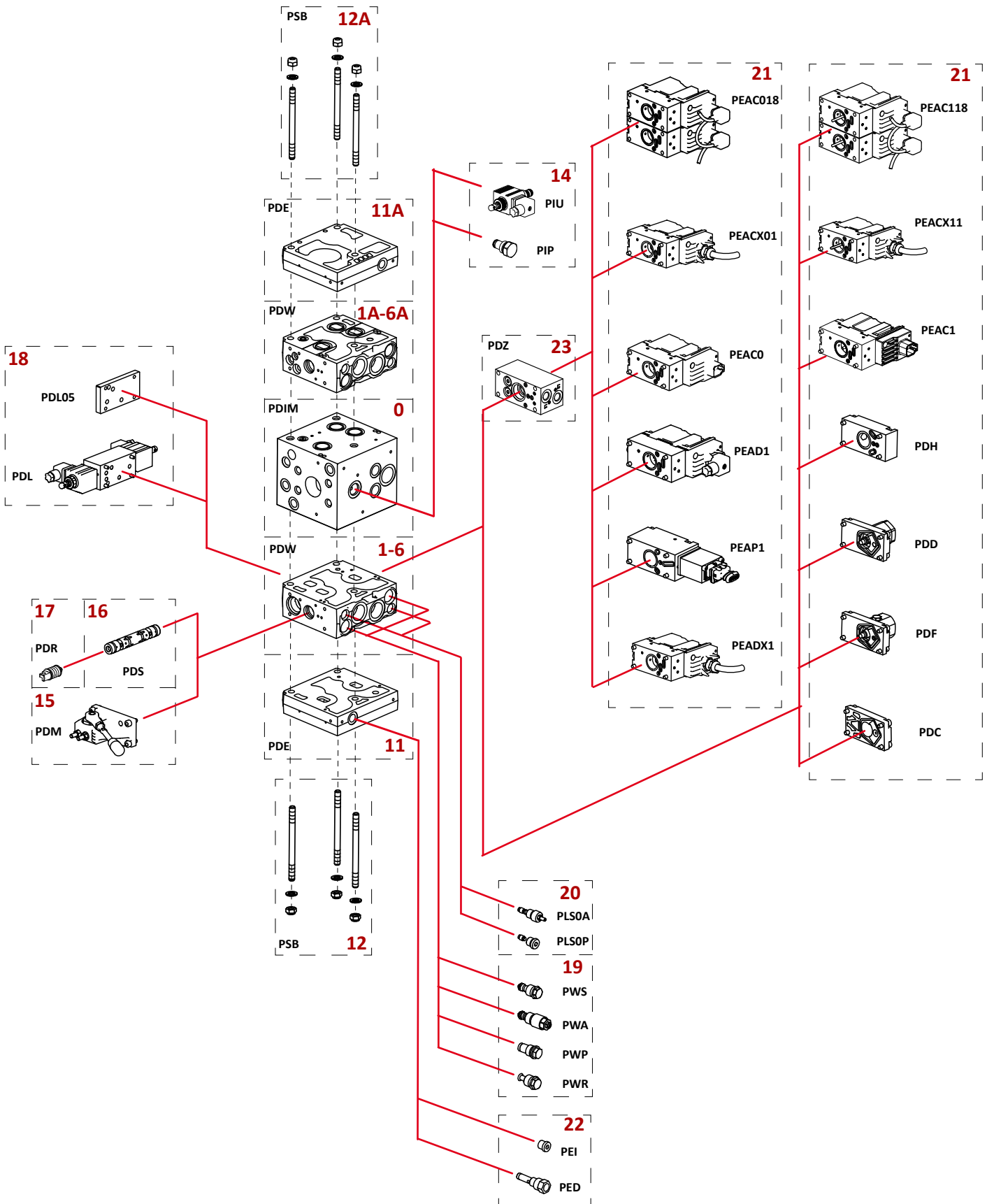

Reference field	Description			Code numbers see pag
		Closed centre	PDI	158
1-6 1A-6A	Working sections	with pressure compensator	PDW	161 - 162
		without pressure compensator		163 - 164
11 11A	End sections		PDE	165 - 166
12 12A	Stay bolt set		PSB	263
14	Solenoid Ls unloading		PIU	159 - 160
	Plug for LS unloading cavity		PIP	159
15	Mechanical actuation		PDM	179
16	Spool		PDS	From 170 to 178
17	Spool centered set		PDR	From 172 to 178
18	Unloading module		PDL	From 186 to 190
	Cover plate		PDL05	
19	Shock and suction valve	not adjustable	PWS	183-184
		adjustable	PWA	183-184
	Plug for shock and suction valve cavity		PWP	185
	Suction valve		PWR	185
20	Pilot pressure LS _{A/B} relief valve		PLS0A	180
	Set plug LS _{A/B} cavity		PLS0P	180
21	Proportional electro-hydraulic actuations	Open loop spool control current signal for PWM and ON-OFF control	PEAD1	From 236 to 241
		Open loop spool control high resolution	PEAC0	From 215 to 235
		Closed loop spool control high performance resolution	PEAC1	From 191 to 214
		Open loop spool control high resolution CAN-Bus	PEAC018	
		Closed loop spool control high performance resolution CAN-Bus	PEAC118	
		Open loop spool control high resolution ATEX	PEACX01	
		Closed loop spool control high performance resolution ATEX version	PEACX11	
		Open loop spool control current signal for PWM and ON-OFF control ATEX version	PEADX1	
		Open loop spool control current input signal for PWM and ON-OFF control - AMP JPT 4 pin	PEAP1	From 242 to 247
	Rear cover for	Hydraulic control	PDH	180
		Detent	PDD	181
		Friction detent	PDF	179
		Mechanical actuation	PDC	180
22	End sections	External drain line cartridge	PED	182
		Internal plug	PEI	182
23	Dual function control body		PDZ	168 - 169
24	Pump pressure relief valve		PRV0A	
	Plug for relief valve cavity		PRV0P	

PDV114 + PDV74 Proportional valve, product selection chart

Standard configuration

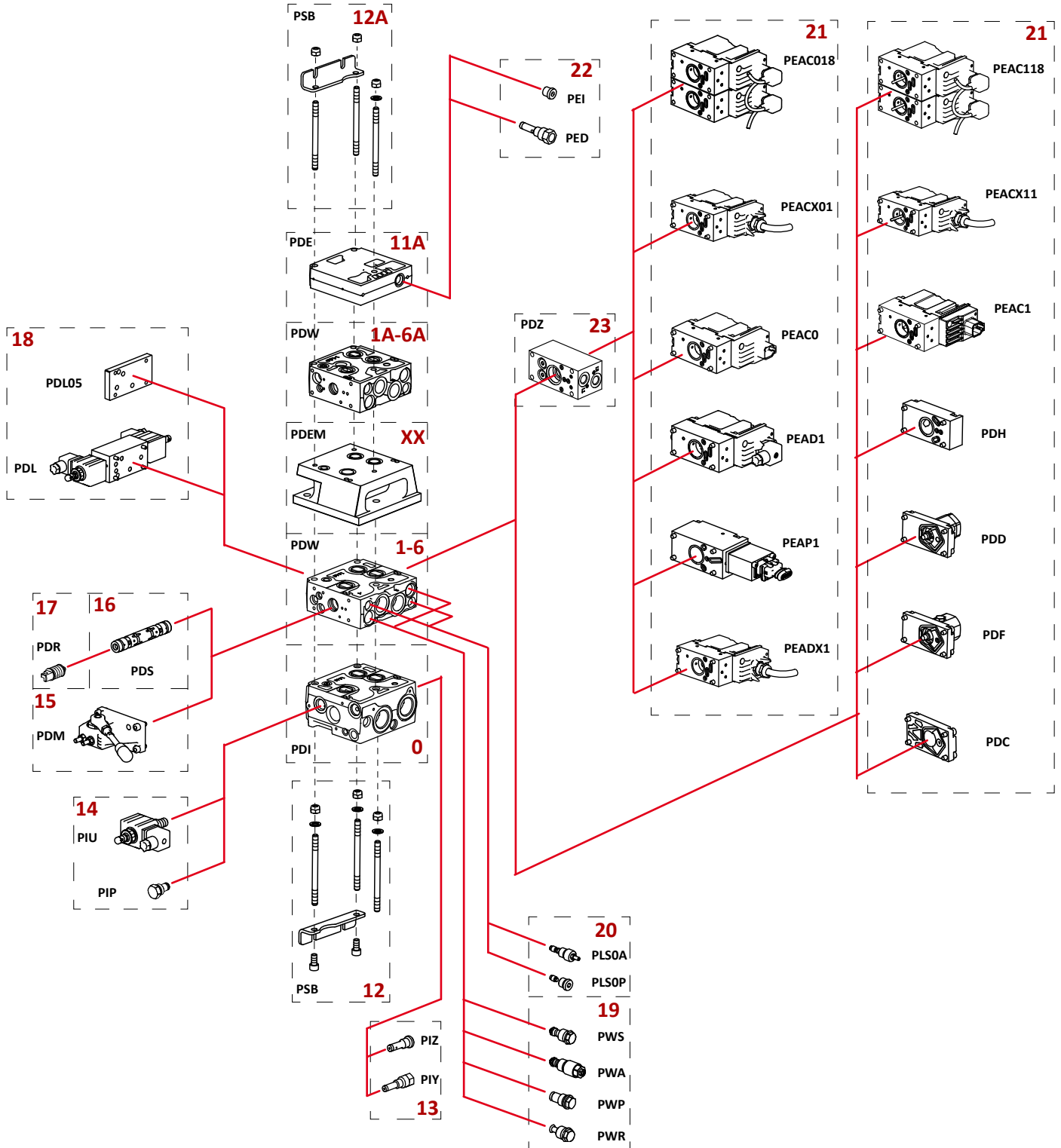

Reference field	Description			Code numbers see pag
0	Inlet sections	Open centre	PDI	155 - 156
		Closed centre		157 - 158
1-10	Working sections	with pressure compensator	PDW	161 - 162
		without pressure compensator		163 - 164
11	End sections		PDE	165 - 166
12	Stay bolt set		PSB	252
13	Pilot oil supply cartridge	Internal	PIZ	182
		External	PIY	182
14	Solenoid Ls unloading		PIU	159 - 160
	Plug for LS unloading cavity		PIP	159
15	Mechanical actuation		PDM	179
16	Spool		PDS	From 170 to 178
17	Spool centered set		PDR	From 172 to 178
18	Unloading module		PDL	From 186 to 190
	Cover plate		PDL05	
19	Shock and suction valve	not adjustable	PWS	183-184
		adjustable	PWA	183-184
	Plug for shock and suction valve cavity		PWP	185
	Suction valve		PWR	185
20	Pilot pressure LS _{A/B} relief valve		PLS0A	180
	Set plug LS _{A/B} cavity		PLS0P	180
21	Proportional electro-hydraulic actuations	Open loop spool control current signal for PWM and ON-OFF control	PEAD1	From 236 to 241
		Open loop spool control high resolution	PEAC0	From 215 to 235
		Closed loop spool control high performance resolution	PEAC1	From 191 to 214
		Open loop spool control high resolution CAN-Bus	PEAC018	
		Closed loop spool control high performance resolution CAN-Bus	PEAC118	
		Open loop spool control high resolution ATEX	PEACX01	
		Closed loop spool control high performance resolution ATEX version	PEACX11	
		Open loop spool control current signal for PWM and ON-OFF control ATEX version	PEADX1	
		Open loop spool control current input signal for PWM and ON-OFF control - AMP JPT 4 pin	PEAP1	From 242 to 247
	Rear cover for	Hydraulic control	PDH	180
		Detent	PDD	181
		Friction detent	PDF	179
Mechanical actuation		PDC	180	
22	End sections	External drain line cartridge	PED	182
		Internal plug	PEI	182
23	Dual function control body		PDZ	168 - 169

PDV114 + PDV74 Proportional Valve PDV Mid-end configuration

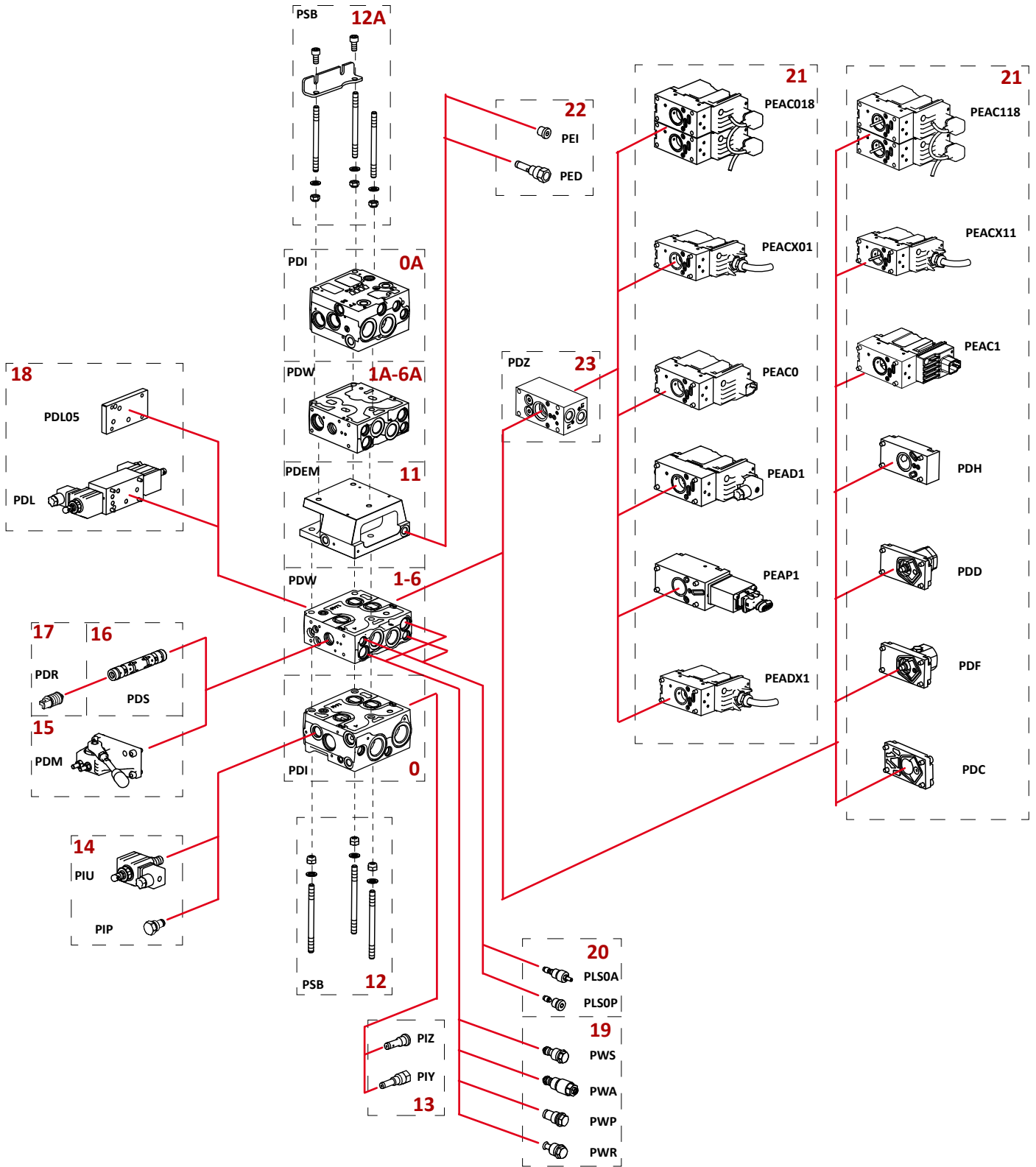

Reference field	Description		Code numbers see pag
0 0A	Inlet sections	Open centre	PDI
		Closed centre	
1-6 1A-6A	Working sections	with pressure compensator	PDW
		without pressure compensator	
11	End sections		PDE
12 12A	Stay bolt set		PSB 258
13	Pilot oil supply cartridge	Internal	PIZ
		External	PIY
14	Solenoid Ls unloading		PIU
	Plug for LS unloading cavity		PIP
15	Mechanical actuation		PDM
16	Spool		PDS
17	Spool centered set		PDR
18	Unloading module		PDL
	Cover plate		PDL05
19	Shock and suction valve	not adjustable	PWS
		adjustable	PWA
	Plug for shock and suction valve cavity		PWP
	Suction valve		PWR
20	Pilot pressure LS _{A/B} relief valve		PLS0A
	Set plug LS _{A/B} cavity		PLS0P
21	Proportional electro-hydraulic actuations	Open loop spool control current signal for PWM and ON-OFF control	PEAD1
		Open loop spool control high resolution	PEAC0
		Closed loop spool control high performance resolution	PEAC1
		Open loop spool control high resolution CAN-Bus	PEAC018
		Closed loop spool control high performance resolution CAN-Bus	PEAC118
		Open loop spool control high resolution ATEX	PEACX01
		Closed loop spool control high performance resolution ATEX version	PEACX11
		Open loop spool control current signal for PWM and ON-OFF control ATEX version	PEADX1
		Open loop spool control current input signal for PWM and ON-OFF control - AMP JPT 4 pin	PEAP1
	Rear cover for	Hydraulic control	PDH
		Detent	PDD
		Friction detent	PDF
		Mechanical actuation	PDC
	22	End sections	External drain line cartridge
Internal plug			PEI
23	Dual function control body		PDZ 32 - 33

PDV114 + PDV74 Proportional Valve Configuration with MID inlet section

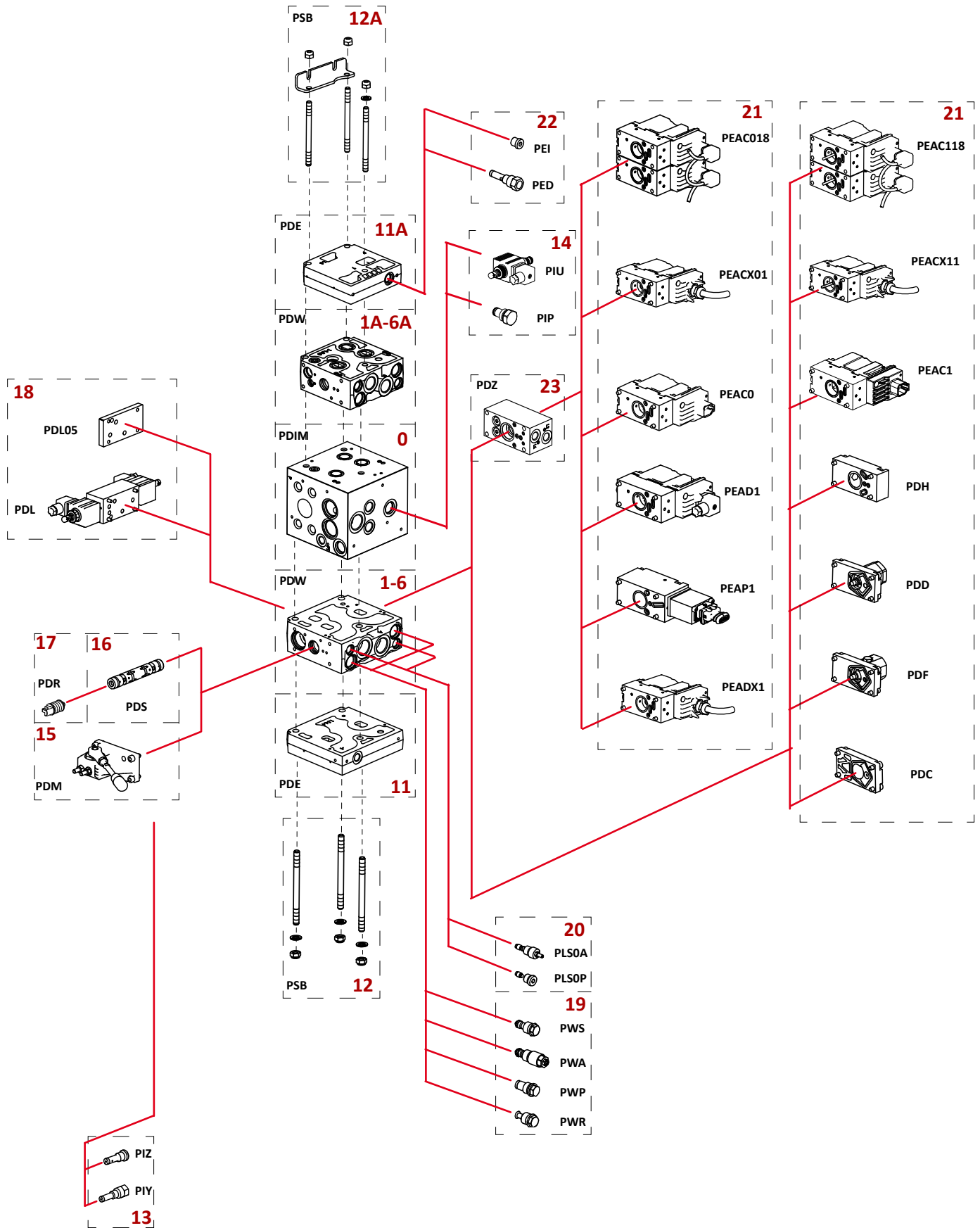

Reference field	Description		Code numbers see pag
0	Inlet sections	Open centre	PDI 20 - 21
		Closed centre	22 - 23
1-6 1A-6A	Working sections	with pressure compensator	PDW 26 - 27
		without pressure compensator	28 - 29
11 11A	End sections		PDE 30 - 31
12 12A	Stay bolt set		PSB 263
14	Solenoid Ls unloading		PIU 24 - 25
	Plug for LS unloading cavity		PIP 24
15	Mechanical actuation		PDM 43
16	Spool		PDS From 34 to 42
17	Spool centered set		PDR From 36 to 42
18	Unloading module		PDL From 49 to 53
	Cover plate		PDL05
19	Shock and suction valve	not adjustable	PWS 46 - 47
		adjustable	PWA 46 - 47
	Plug for shock and suction valve cavity		PWP 48
	Suction valve		PWR 48
20	Pilot pressure LS _{A/B} relief valve		PLS0A 44
	Set plug LS _{A/B} cavity		PLS0P 44
21	Proportional electro-hydraulic actuations	Open loop spool control current signal for PWM and ON-OFF control	PEAD1 From 99 to 104
		Open loop spool control high resolution	PEAC0 From 78 to 98
		Closed loop spool control high performance resolution	PEAC1 From 54 to 77
		Open loop spool control high resolution CAN-Bus	PEAC018
		Closed loop spool control high performance resolution CAN-Bus	PEAC118
		Open loop spool control high resolution ATEX	PEACX01
		Closed loop spool control high performance resolution ATEX version	PEACX11
		Open loop spool control current signal for PWM and ON-OFF control ATEX version	PEADX1
		Open loop spool control current input signal for PWM and ON-OFF control - AMP JPT 4 pin	PEAP1
	Rear cover for	Hydraulic control	PDH 44
		Detent	PDD
		Friction detent	PDF 43
		Mechanical actuation	PDC 44
	22	End sections	External drain line cartridge
Internal plug			PEI 45
23	Dual function control body		PDZ 32 - 33

PDV114 Proportional valve

Composition form for standard inlet section

OMFB HYDRAULIC POWER CONTROL		Code: PDV114			Customer:																																			
		Date: / /			Customer ref:																																			
		Review index: -			Issued by:																																			
		Review date: -			OMFB sales ref:																																			
1	Valve type:	PDV 114	5	Working sections Up:	10	9	Rated voltage [V]:	12																																
2	Type of threads:	BSPP	6	Working sections Down:		10	Certifications:	None																																
3	Type of inlet:	standard	7	Inlet section side:	Right version	11																																		
4	Pump type:	Open Center	8	2 nd pump type:		12	Pump flow [l/min]:																																	
Notes:		<table border="1" style="margin: auto;"> <tr> <td style="text-align: center;">B Port</td> <td style="text-align: center;">0</td> <td style="text-align: center;">bar</td> <td></td> <td></td> <td></td> <td style="text-align: center;">13</td> <td style="text-align: center;">A Port</td> </tr> <tr> <td style="text-align: center;">Actuators side</td> <td></td> <td></td> <td></td> <td></td> <td></td> <td></td> <td style="text-align: center;">Handle side</td> </tr> <tr> <td></td> <td></td> <td></td> <td></td> <td></td> <td></td> <td></td> <td></td> </tr> <tr> <td></td> <td></td> <td></td> <td></td> <td></td> <td></td> <td></td> <td></td> </tr> </table>					B Port	0	bar				13	A Port	Actuators side							Handle side																	Notes:	
B Port	0	bar				13	A Port																																	
Actuators side							Handle side																																	
1		21		1	bar			bar	16		15																													
		17		20					20																															
				19					19																															
				18																																				
2		21		2	bar			bar	16		15																													
		17		20					20																															
				19					19																															
3		21		3	bar			bar	16		15																													
		17		20					20																															
				19					19																															
4		21		4	bar			bar	16		15																													
		17		20					20																															
				19					19																															
5		21		5	bar			bar	16		15																													
		17		20					20																															
				19					19																															
6		21		6	bar			bar	16		15																													
		17		20					20																															
				19					19																															
7		21		7	bar			bar	16		15																													
		17		20					20																															
				19					19																															
8		21		8	bar			bar	16		15																													
		17		20					20																															
				19					19																															
9		21		9	bar			bar	16		15																													
		17		20					20																															
				19					19																															
10		21		10	bar			bar	16		15																													
		17		20					20																															
				19					19																															



HYDRAULIC POWER CONTROL

PDV114 Proportional valve Composition form with double inlet section and MID End section

OMFB HYDRAULIC POWER CONTROL				Code: PDV114	Customer:
				Date: / /	Customer ref:
				Review index: -	Issued by:
				Review date: -	OMFB sales ref:
1 Valve type:	PDV 114	5 Working sections Up:	6	9 Rated voltage [V]:	12
2 Type of threads:	BSP	6 Working sections Down:	6	10 Certifications:	None
3 Type of inlet:	mid_end	7 Inlet section side:	Right version	11	
4 Pump type:	Open Center	8 2 nd pump type:		12 Pump flow [l/min]:	

Notes:	B Port	0A bar			13	A Port	Notes:
	Actuators side				14	Handle side	

1A	21		1A bar			bar	16		15
	17		20				20		
			19				19		
			18						
2A	21		2A bar			bar	16		15
	17		20				20		
			19				19		
			18						
3A	21		3A bar			bar	16		15
	17		20				20		
			19				19		
			18						
4A	21		4A bar			bar	16		15
	17		20				20		
			19				19		
			18						
5A	21		5A bar			bar	16		15
	17		20				20		
			19				19		
			18						
6A	21		6A bar			bar	16		15
	17		20				20		
			19				19		
			18						

11					12
12A					

6	21		6 bar			bar	16		15
	17		20				20		
			19				19		
			18						
5	21		5 bar			bar	16		15
	17		20				20		
			19				19		
			18						
4	21		4 bar			bar	16		15
	17		20				20		
			19				19		
			18						
3	21		3 bar			bar	16		15
	17		20				20		
			19				19		
			18						
2	21		2 bar			bar	16		15
	17		20				20		
			19				19		
			18						
1	21		1 bar			bar	16		15
	17		20				20		
			19				19		
			18						

Notes:	A Port	0 bar			13	B Port	Notes:
	Actuators side				14	Handle side	

PDV114 Proportional valve Composition form with MID inlet section

OMFB HYDRAULIC POWER CONTROL				Code: PDV114				Customer:									
				Date: / /				Customer ref:									
				Review index: -				Issued by:									
				Review date: -				OMFB sales ref:									
1	Valve type:	PDV 114	5	Working sections Up:	6	9	Rated voltage [V]:	12	2	Type of threads:	BSPP	6	Working sections Down:	6	10	Certifications:	None
3	Type of inlet:	mid_inlet	7	Inlet section side:	Right version	11			4	Pump type:	Open Center	8	2 nd pump type:		12	Pump flow [l/min]:	

	A Port		11A			12A	B Port		
Notes:	Actuators side		22				Handle side		Notes:

6A		21	6A	bar		bar	16		15
		17	20				20		
			19				19		
			18						
5A		21	5A	bar		bar	16		15
		17	20				20		
			19				19		
			18						
4A		21	4A	bar		bar	16		15
		17	20				20		
			19				19		
			18						
3A		21	3A	bar		bar	16		15
		17	20				20		
			19				19		
			18						
2A		21	2A	bar		bar	16		15
		17	20				20		
			19				19		
			18						
1A		21	1A	bar		bar	16		15
		17	20				20		
			19				19		
			18						

0	bar			14

1		21	1	bar		bar	16		15
		17	20				20		
			19				19		
			18						
2		21	2	bar		bar	16		15
		17	20				20		
			19				19		
			18						
3		21	3	bar		bar	16		15
		17	20				20		
			19				19		
			18						
4		21	4	bar		bar	16		15
		17	20				20		
			19				19		
			18						
5		21	5	bar		bar	16		15
		17	20				20		
			19				19		
			18						
6		21	6	bar		bar	16		15
		17	20				20		
			19				19		
			18						

	B Port		11			12	A Port		
	Actuators side		22				Handle side		